



DESIGNED SMART. BUILT SOLID.®

## INSTALLATION AND OPERATING INSTRUCTIONS

### Hot Food Wells

**Top Mount Models: Models: HFW-2 thru 6 & HFW-2D thru 6D**

**Slimline Insulated Models: HFWS-2 thru 4**

INTENDED FOR OTHER THAN HOUSEHOLD USE



**WARNING:** California Residents Only. This product can expose you to chemicals including chromium which is known to the State of California to cause cancer and birth defects or other reproductive harm. For more information go to [www.P65Warnings.ca.gov](http://www.P65Warnings.ca.gov).



**WARNING:** Improper installation, operation, service or maintenance can cause property damage, injury or death. Read and understand these instructions thoroughly before positioning, installing, maintaining or servicing this equipment.



APW Wyott® cooking equipment has been engineered to provide you with year-round dependable service when used according to the instructions in this manual and standard commercial kitchen practices.



P/N 79967133 09/18

**APW Wyott Food Service Equipment Company**  
1307 N. Watters Road, Suite 180 • Allen, TX 75013

APW Wyott Food Service Equipment Company is a wholly owned subsidiary of Standex International Corporation.

972.908.6100 Phone  
214.565.0976 Fax

+1.800.527.2100  
[www.apwwyott.com](http://www.apwwyott.com)

## TABLE OF CONTENTS

ITEM.....	PAGE	ITEM.....	PAGE
Safety Precautions .....	2	Exploded View & Parts List	
General Information .....	4	HFW-2 thru HFW-6 (Thermostat Control) ...	7
General Troubleshooting .....	4	Exploded View & Parts List	
Installation .....	5	HFW-2 thru HFW-6 (Infinite Control) .....	9
General & Electrical Specifications		Exploded View & Parts List	
HFW-2 thru HFW .....	5	HFWS-2 thru HFWS-4	
General & Electrical Specifications		(Thermostat & Infinite Control) .....	11
HFWS-2 thru HFWS-4 .....	6	Wiring Diagrams .....	13
Operation & Cleaning .....	6	Warranty .....	16

### Immediately Inspect For Shipping Damage

All containers should be examined for damage before and during unloading. The freight carrier has assumed responsibility for its safe transit and deliver. If equipment is received damaged, either apparent or concealed, a claim must be made with the delivering carrier.

- A) Apparent damage or loss must be noted on the freight bill at the time of delivery. It must then be signed by the carrier representative (Driver). If this is not done, the carrier may refuse the claim. The carrier can supply the necessary forms.
- B) Concealed damage or loss if not apparent until after equipment is uncrated, a request for inspection must be made to the carrier within 15 days. The carrier should arrange an inspection. Be certain to hold all contents and packaging material.

Installation and start-up should be performed by a qualified installer who thoroughly read, understands and follows these instructions.

**APW Wyott** takes pride in the design and quality of our products. When used as intended and with proper care and maintenance, you will experience years of reliable operation from this equipment. To ensure best results, it is important that you read and follow the instructions in this manual carefully.









Installation and start-up should be performed by a qualified installer who thoroughly read, understands and follows these instructions.

If you have questions concerning the installation, operation, maintenance or service of this product, contact APW Wyott Foodservice Equipment Company's "Technical Service Department."

## SAFETY PRECAUTIONS

Before installing and operating your APW Wyott® cooking equipment be sure everyone involved in its operation are fully trained and are aware of all precautions. Accidents and problems can result by a failure to follow fundamental rules and precautions.

The following words and symbols, found in this manual, alert you to hazards to the operator, service personnel or the equipment. The words are defined as follows:

	<b>DANGER:</b> This symbol warns of imminent hazard which will result in serious injury or death.	
	<b>WARNING:</b> This symbol refers to a potential hazard or unsafe practice, which could result in serious injury or death.	
	<b>CAUTION:</b> This symbol refers to a potential hazard or unsafe practice, which may result in minor or moderate injury or product or property damage.	
	<b>NOTICE:</b> This symbol refers to information that needs special attention or must be fully understood even though not dangerous.	



**CAUTION:** These models are designed, built, and sold for commercial use. If these models are positioned so the general public can use the equipment make sure that cautions, warnings, and operating instructions are clearly posted near each unit so that anyone using the equipment will use it correctly and not injure themselves or harm the equipment.



**WARNING:** Check the data plate on this unit before installation. Connect the unit only to the voltage and frequency listed on the data plate. Connect only to 1 or 3 phase as listed on the data plate.



**WARNING:** In Europe, appliance must be connected by an earthing cable to all other units in the complete installation and thence to an independent earth connection in compliance with EN 60335-1 and/or local codes.



**WARNING:** For your safety do not store or use gasoline or other flammable vapors or liquids in the vicinity of this or any other appliance. Keep the area free and clear of combustibles. (See ANZI Z83.14B, 1991)



**NOTICE:** This equipment has been engineered to provide you with year round dependable service when used according to the instructions in this manual and standard commercial kitchen practices.



**WARNING:** Install per the spacing requirements listed in the installation section of this manual. We strongly recommend having a competent professional install the equipment. A licensed electrician should make the electrical connections and connect power to the unit. Local codes should always be used when connecting these units to electrical power. In the absence of local codes, use the latest version of the National Electrical Code.



**WARNING:** This device should be safely and adequately grounded in accordance with local codes, or in the absence of local codes, with the National Electrical code, ANSI/NFPA70, latest edition to protect the user from electrical shock. It requires a grounded system and a dedicated circuit, protected by a fuse or circuit breaker of proper size and rating. Canadian installation must comply with the Canadian Electrical Code, CSA C22.2, as applicable.



**WARNING:** An earthing cable must connect the appliance to all other units in the complete installation and from there to an independent earth connection.



**NOTICE:** Local codes regarding installation vary greatly from one area to another. The National Fire Protection Association, Inc. states in its NFPA96 latest edition that local codes are "Authority Having Jurisdiction" when it comes to requirement for installation of equipment. Therefore, installation should comply with all local codes.



**WARNING:** Unit is not waterproof. Do not submerge in water. Do not operate if it has been submerged in water. Do not clean the unit with a water jet.



## GENERAL INFORMATION

### General Installation

1. Always clean equipment thoroughly before first use. (See general cleaning instructions.)
2. Check rating label for your model designation & electrical rating.
3. For best results, use stainless steel countertops.
4. All dimensions in parenthesis in centimeters, unless noted.

### General Operating Instructions:

1. All food service equipment should be operated by trained personnel.
2. Do not allow your customers to come in contact with any surface labeled "CAUTION HOT."
3. Where applicable: Never pour cold water into dry heated units.
4. Where applicable, do not cook, warm or hold food directly in liner pans (well pans). Always use steam table pans/insets, etc.
5. Never hold food below 150°F (66°C)

### Wet set-up and operation procedures:

1. Add hot water 120°-140°F (50°-60°C) to well pan: (12x20) use: 3.75 Quarts (15 Cups) (3.5 Liters)
2. Turn thermostat control to "10" setting or if equipped with infinite control to "7" or "High". Preheat for approximately 30 minutes.
3. Place covered inset with preheated product into well.
4. Re-adjust control after another 30 minutes of operation to acquire desired temperature depending on the amount and thickness of product.
5. Keep inset/steamtable pan(s) covered to maintain ideal serving temperature.
6. Do not let well run dry.

### General Cleaning Instructions:

1. NEVER clean any electrical unit by immersing it in water. Turn off before surface cleaning.
2. Always clean equipment thoroughly before first use. Clean unit daily. Use warm, soapy water (except where noted on charts). Mild cleansers and PLASTIC scouring pads may be used to remove baked-on food and water scale.
3. Turn off electrical units before cleaning or servicing. All service should be performed by an APW Wyott authorized service agency.

## GENERAL TROUBLESHOOTING

### Always Ask & Check:

1. Is the unit connected to a live power source?
2. Check circuit breaker.
3. Is power switch on & pilot light glowing?
4. Check rating label. Are you operating unit on proper voltage?

## INSTALLATION

1. Follow General Installation Instructions on page 4 (above.).
2. Make applicable Cut-Out per below table. Note: Unit is designed for installation in stainless steel tops.
3. Apply putty tape to underside perimeter of the well rim outer edge.
4. Apply a 1/4" (.6) bead of silicone sealant adjacent to the putty tape on the well flange.
5. Drop well into opening from the top and push down until entire perimeter of rim is flush with the counter surface.
6. From below the counter surface insert an #8 to #10 (20 to 25 cm) flat tip screwdriver into the locking ring tab slots and twist in a clockwise motion to lock well in place.
7. Trim excess putty and sealant from around well rim.
8. Mount control to front panel using hardware. Maintain 4" (10.2) clearance between well and front panel.
9. Check nameplate for proper voltage. Connect power.

**! Note:** Electrically connect units to comply with local and NEC codes. **!**

### GENERAL SPECIFICATIONS (All Models HFW)

Model	Outside Dimensions			Cut Out		Control Cut Out	Shipping Weight
	A	B	C	A	B		
HFW-2 Well	29.750 (75.6)	23.438 (59.5)	28.122 (71.4)	28.622 (72.7)	22.500 (57.2)	See Above	89 Lbs. (40.4 Kg)
HFW-3 Well	44.125 (112.1)	23.438 (59.5)	42.497 (107.9)	42.997 (109.2)	22.500 (57.2)	See Above	139 Lbs. (63.0 Kg)
HFW-4 Well	58.500 (148.6)	23.438 (59.5)	56.872 (144.4)	57.372 (145.7)	22.500 (57.2)	See Above	169 Lbs. (76.7 Kg)
HFW-5 Well	72.875 (185.1)	23.438 (59.5)	71.247 (181.0)	71.747 (182.2)	22.500 (57.2)	See Above	199 Lbs. (90.3 Kg)
HFW-6 Well	87.250 (221.6)	23.438 (59.5)	85.622 (217.5)	86.122 (218.7)	22.500 (57.2)	See Above	251 Lbs. (113.9 Kg)

### ELECTRICAL SPECIFICATIONS

MODEL	Electrical Ratings				Electrical Ratings			
	Volts	Watts	Amps	Max Amps (3ph)	Volts	Watts	Amps	Max Amps (3ph)
HFW-2 Well	208/240	2400/3200	11.5/13.3	6.7/7.7	208	3200	15.4	8.9
HFW-3 Well	208/240	3600/4800	17.3/20.0	10.0/11.6	208	4800	23.1	13.4
HFW-4 Well	208/240	4800/6400	23.1/26.7	13.3/15.4	208	6400	30.8	17.8
HFW-5 Well	208/240	6000/8000	28.8/33.3	16.7/19.2	208	8000	38.5	22.3
HFW-6 Well	208/240	7200/9600	34.6/40.0	20.0/23.2	208	9600	46.2	26.7
1200W Each @ 208, 1600W Each @ 240V					1600W Each @ 208			

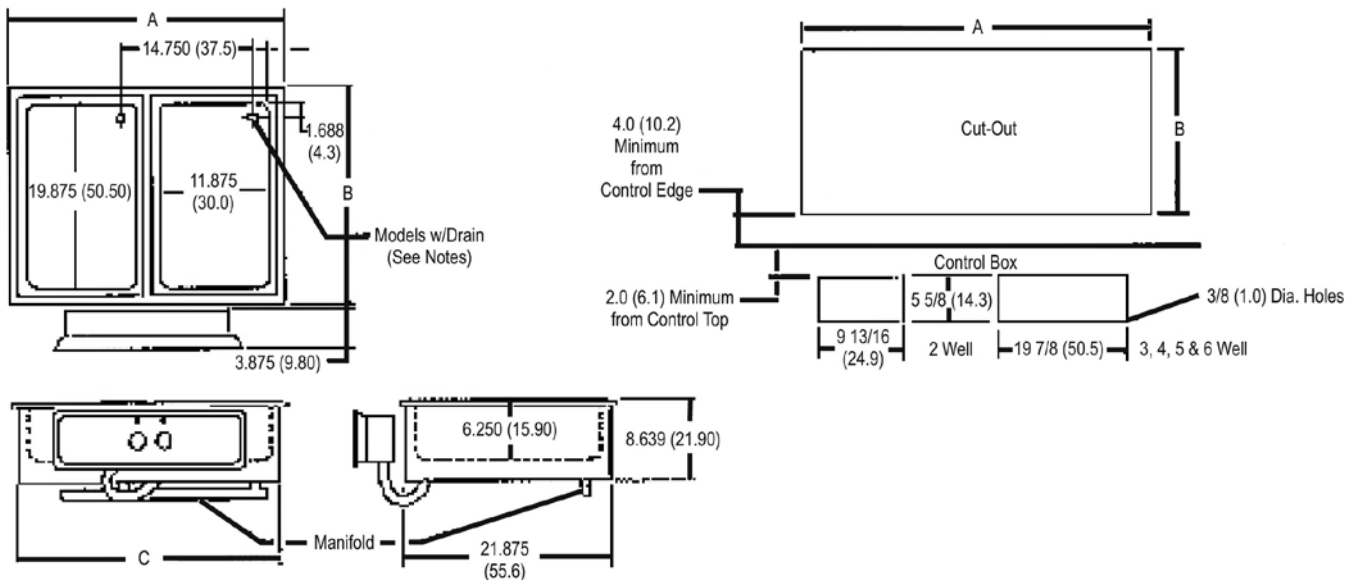

## GENERAL SPECIFICATIONS (All Models HFWS)

Model	Outside Dimensions			Well Cut Out		Control Cut Out			Shipping Weight
	A	B	C	D	E	F	G	H	
HFWS-2 Well	45.409 (115.3)	15.055 (38.2)	43.781 (111.2)	44.500 (113.0)	14.125 (35.9)	5.62	9.81	N/A	89 Lbs. (40.4 Kg)
HFWS-3 Well	67.451 (171.3)	15.055 (38.2)	65.823 (167.2)	66.500 (168.9)	14.125 (35.9)	5.62	N/A	19.87	120 Lbs. (54.4 Kg)
HFWS-4 Well	89.493 (227.3)	15.055 (38.2)	87.865 (223.2)	88.500 (224.8)	14.125 (35.9)	5.62	N/A	19.87	159 Lbs. (72.0 Kg)

## ELECTRICAL SPECIFICATIONS

Model	Electrical Ratings				Electrical Ratings			
	Volts	Watts	Amps	Max Amps (3ph)	Volts	Watts	Amps (1ph)	Max Amps (3ph)
HFWS-2 Well	208/240	2400/3200	11.5/13.3	10.0/11.6	208	3200	15.4	13.4
HFWS-3 Well	208/240	3600/4800	17.3/20.0	10.0/11.6	208	4800	23.0	13.4
HFWS-4 Well	208/240	4800/6400	23.1/26.7	15.3/17.4	208	6400	30.8	20.4
	1200W Each @ 208, 1600W Each @ 240V				1600W Each @ 208			

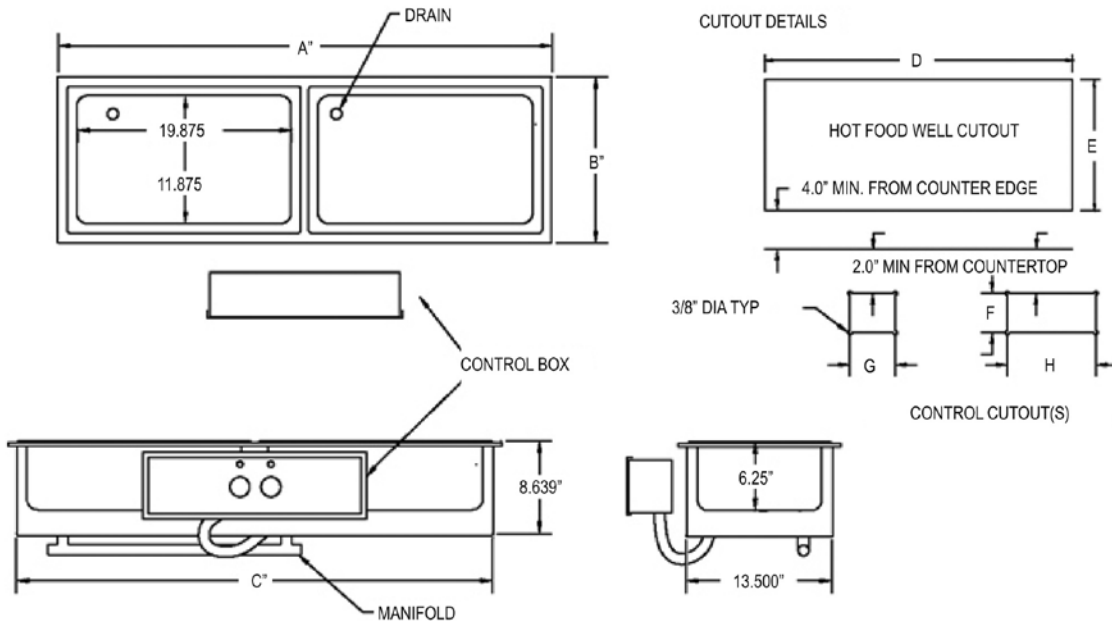

## OPERATION & CLEANING

1. Follow General Operating & General Cleaning Instructions on page 4.

**EXPLODED VIEW - THERMOSTAT CONTROL (HFW-2, -3, -4, -5, -6)**

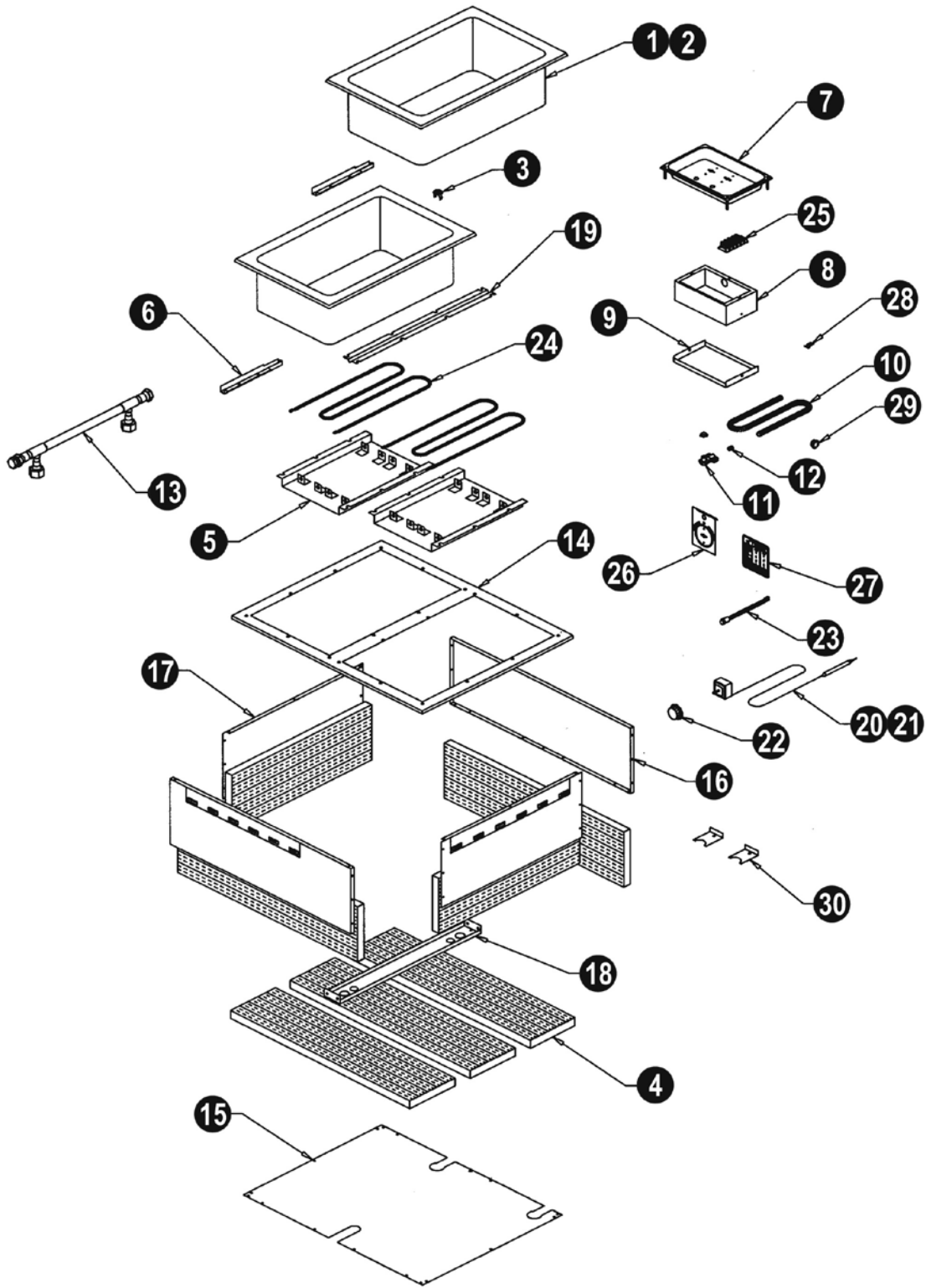

Parts List – Thermosttic Control (HFW-2, -3, -4, -5, -6)		
Item	Part No.	Description
1	55071	WELL PAN NO DRAIN
2	56037	WELL PAN W/DRAIN
3	56655	DRAIN STRAINER
4	60150	1" X 7" X 48" INSULATION
5	56506	REFLECTOR PAN
6	56039	CAPILLARY COVER F/T'STATS
7	55055	CONTROL RECESSED BEZEL
7A	56041	CONTROL RECESSED BEZEL
8	55057	CONDUIT BOX
8A	55063	CONDUIT BOX
9	55065	CONDUIT BOX COVER
9A	55066	CONDUIT BOX COVER
10	55099	3/4" CONDUIT 24" LONG
11	55058	90° CONDUIT CONNECTOR
12	55059	ANTI-SHORT BUSHING
13	56138	2 WELL DRAIN MANIFOLD ASSY
13A	56147	3 WELL DRAIN MANIFOLD ASSY
13B	56148	4 WELL DRAIN MANIFOLD ASSY
13C	56149	5 WELL DRAIN MANIFOLD ASSY
13D	56150	6 WELL DRAIN MANIFOLD ASSY
14	56206	2 WELL TOP PLATE
14A	56351	3 WELL TOP PLATE
14B	56377	4 WELL TOP PLATE
14C	55023	5 WELL TOP PLATE
14D	56166	6 WELL TOP PLATE
15	56181	2 WELL BOTTOM COVER
15A	56178	3 WELL BOTTOM COVER
15B	56175	4 WELL BOTTOM COVER
15C	56173	5 WELL BOTTOM COVER
15D	56172	6 WELL BOTTOM COVER
16	56180	2 WELL FRONT OR BACK COVER
16A	56177	3 WELL FRONT OR BACK COVER
16B	56174	4 WELL FRONT OR BACK COVER
16C	56171	5 WELL FRONT OR BACK COVER
16D	56170	6 WELL FRONT OR BACK COVER
17	56050	END COVER - ALL
18	56048	CONDUIT BRACKET
19	56067	WELL BRACE
20	56527	THERMOSTAT 36" CAPILLARY
21	56540	THERMOSTAT 72" CAPILLARY
22	56505	KNOB, THERMOSTAT
23	56530	INDICATOR LIGHT

Parts List – Thermosttic Control (HFW-2, -3, -4, -5, -6)		
Item	Part No.	Description
24	55441	ELEMENT 208/240V 1200/1600W
	54051	ELEMENT 208V 1600W
25	30201	TERMINAL BLOCK
26	56529	INCR./DECR. PLATE
27	56542	DIAL PLATE
28	89120	JIFFY CLIP
29	89184	7/8" HOLE BUSHING
30	55062	HOLE COVER
	89073	#8 X 1/2 SHT METAL SCREW
	88961	10-24 GREEN HEX NUT
	89061	10-24 HEX NUT
	89025	10-24 SPEED NUT
	89071	#10 FLAT WASHER
	89059	#10 EXT. LOCKWASHER
	88993	10-32 X 3/8" TR. HD SCREW
	89068	1/4" FLAT WASHER

Note: When ordering, ALWAYS specify Part #, Model #, Serial #, Voltage/Phase & type of Gas. Form #67133 Rev. 3/16



EXPLODED VIEW - INFINITE CONTROL (HFW-2, -3, -4, -5, -6)

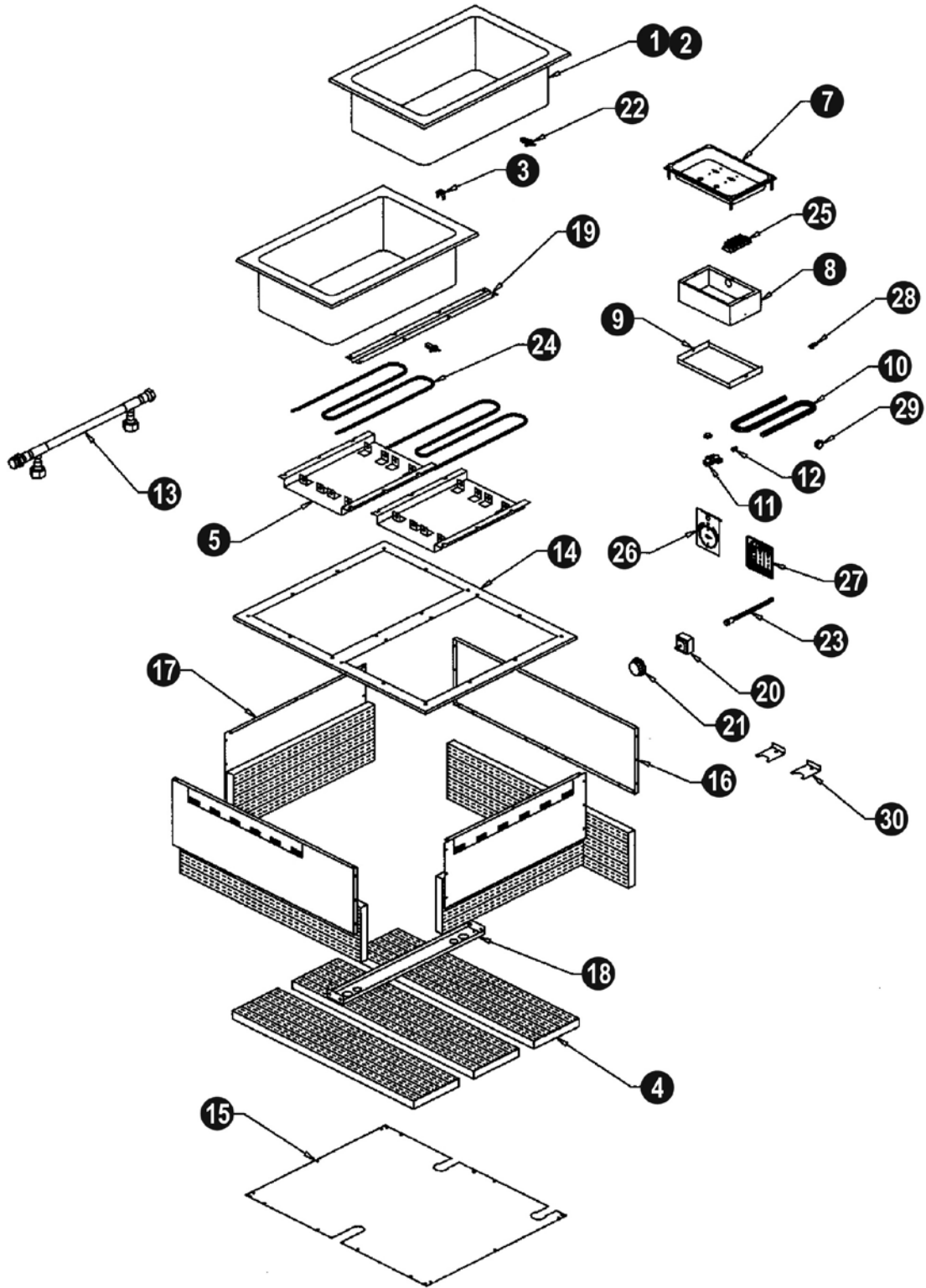

Parts List – Infinite Control (HFW-2, -3, -4, -5, -6)		
Item	Part No.	Description
1	55071	WELL PAN NO DRAIN
2	56037	WELL PAN W/DRAIN
3	56655	DRAIN STRAINER
4	60150	1" X 7" X 48" INSULATION
5	56506	REFLECTOR PAN
6	55065	CONDUIT BOX COVER
7	55055	CONTROL RECESSED BEZEL
7A	56041	CONTROL RECESSED BEZEL
8	55057	CONDUIT BOX
8A	55063	CONDUIT BOX
9	55065	CONDUIT BOX COVER
9A	55066	CONDUIT BOX COVER
10	55099	3/4" CONDUIT 24" LONG
11	55058	90° CONDUIT CONNECTOR
12	55059	ANTI-SHORT BUSHING
13	56138	2 WELL DRAIN MANIFOLD ASSY
13A	56147	3 WELL DRAIN MANIFOLD ASSY
13B	56148	4 WELL DRAIN MANIFOLD ASSY
13C	56149	5 WELL DRAIN MANIFOLD ASSY
13D	56150	6 WELL DRAIN MANIFOLD ASSY
14	56206	2 WELL TOP PLATE
14A	56351	3 WELL TOP PLATE
14B	56377	4 WELL TOP PLATE
14C	55023	5 WELL TOP PLATE
14D	56166	6 WELL TOP PLATE
15	56181	2 WELL BOTTOM COVER
15A	56178	3 WELL BOTTOM COVER
15B	56175	4 WELL BOTTOM COVER
15C	56173	5 WELL BOTTOM COVER
15D	56172	6 WELL BOTTOM COVER
16	56180	2 WELL FRONT OR BACK COVER
16A	56177	3 WELL FRONT OR BACK COVER
16B	56174	4 WELL FRONT OR BACK COVER
16C	56171	5 WELL FRONT OR BACK COVER
16D	56170	6 WELL FRONT OR BACK COVER
17	56050	END COVER - ALL
18	56048	CONDUIT BRACKET
19	56067	WELL BRACE
20	87053-EGO	INFINITE CONTROL
21	55825	KNOB, INFINITE CONTROL
22	69106	LIMITING THERMOSTAT

Parts List – Infinite Control (HFW-2, -3, -4, -5, -6)		
Item	Part No.	Description
23	56530	INDICATOR LIGHT
24	55441	ELEMENT 208/240V 1200/1600W
	54051	ELEMENT 208V 1600W
25	30201	TERMINAL BLOCK
26	56529	INCR./DECR. PLATE
27	56542	DIAL PLATE
28	89120	JIFFY CLIP
29	89184	7/8" HOLE BUSHING
30	55062	HOLE COVER
	89073	#8 X 1/2 SHT METAL SCREW
	88961	10-24 GREEN HEX NUT
	89061	10-24 HEX NUT
	89025	10-24 SPEED NUT
	89071	#10 FLAT WASHER
	89059	#10 EXT. LOCKWASHER
	88993	10-32 X 3/8" TR. HD SCREW
	89068	1/4" FLAT WASHER

Note: When ordering, ALWAYS specify Part #, Model #, Serial #, Voltage/Phase & type of Gas. Form #67132 Rev. 3/16

**EXPLODED VIEW - THERMOSTATIC OR INFINITE CONTROL (HFWS-2, -3, -4-)**

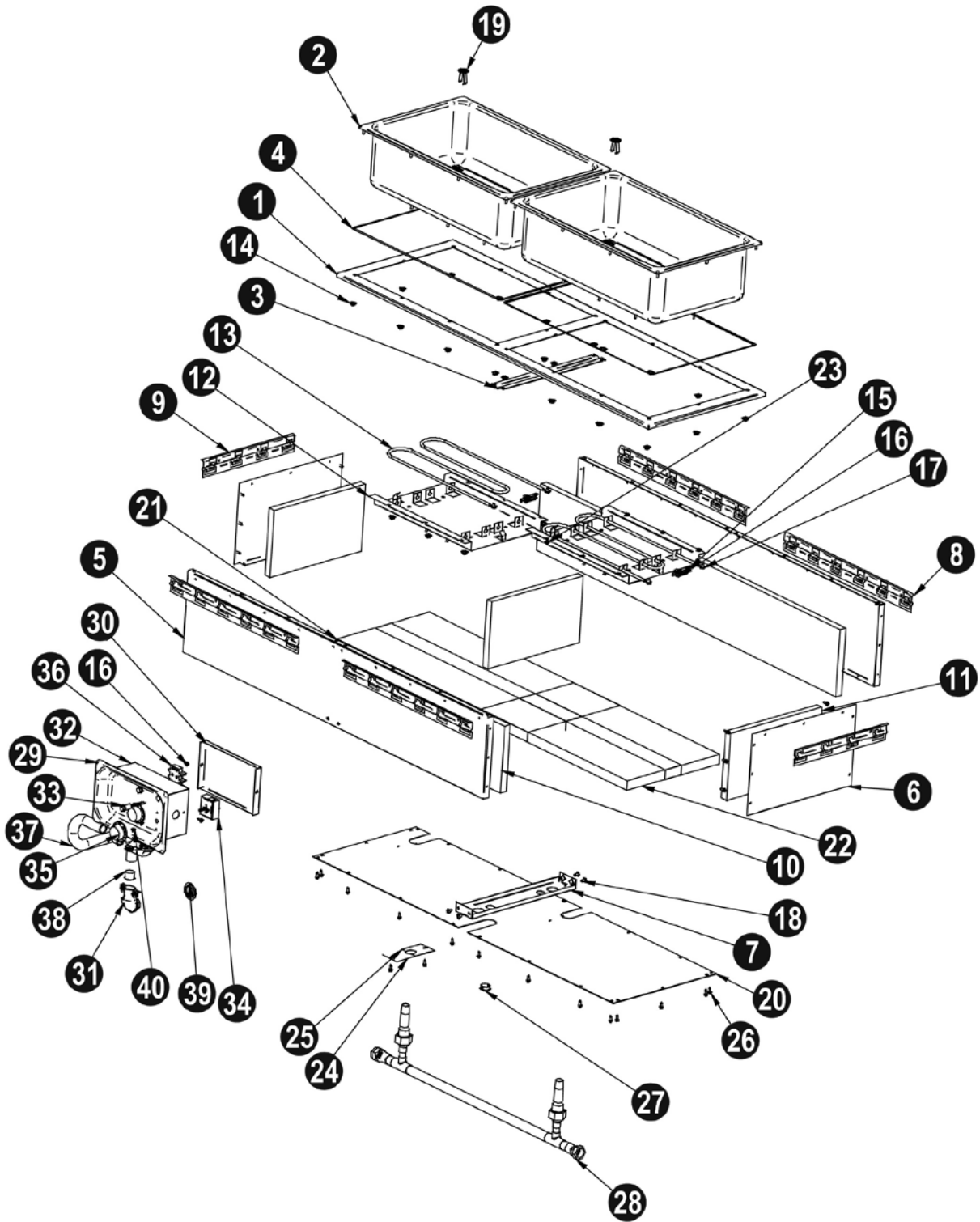

Parts List – HFWS-2, -3, -4			
Item	Part No.	Description	Quantity
1	54905	Base	1
2	56037	600 Well Pan w/Drain Weld Assy	2
3	54902	Brace, Well Runner	1
4	55789	Sealant, Gs7500, 6.5 Ft. Lg.	2
5	54904	Housing, Front and Back	2
6	54903	Housing, End	2
7	54926	W/Ass'y, Conduit Brace	1
8	55308	E-Z Lock, 6 Tab	4
9	55305	E-Z Lock, 4 Tab	2
10	60150	Insulation	2
11	60150	Insulation	3
12	56506	Plate, Reflector	2
13	55441	Element, 1200/1600W – 208/240V	2
14	89025	Nut, Speed 10-24 Pal Zinc	32
15	69106S	Thermostat	2
16	89054	Nut, KEPS 6-32	4
17	89059	Washer #10 External Lock	4
18	88993	Screw 10-32 x 3/8 Trs Hd Phillips	8
19	56655	W/Ass'y, Drain Strainer	2
20	54906	Bottom Cover	1
21	60150	Insulation	2
22	60150	Insulation	2
23	88961	Nut, Hex 10-24, Green	1
24	56388	Plate, Hole Cover	2
25	54564	Plate, Hole Cover	2
26	89073	Screw, #8 x 1/2 Hex Tapit Sht Mtl	40
27	89108	Plug	1
28	54919	Manifold, HFWS-2 Well Slim Line	1
29	12343	Pan, 1/4 Size 200 Series Insert	1
30	55065	Cover, Conduit Box	1
31	55058	Conduit Connector, 90° Flex	2
32	55057	Conduit Box – 2 Well	1
33	56530	Light, Pilot	2
34	87054-EGO	Infinite Switch – Ego	2
35	55825	Knob, Infinite No Logo	2
36	30201	Terminal Block, 600V 50Amp	1
37	55059	Conduit 3/4", Length 24"	1
38	55059	Bushing, Antishort, 3/4", #4	2
39	87822	Washer, Reducing 1 x 3/4	1
40	89087	Screw 8-32 x 3/16 Bndng Hd M/S	4

**WIRING DIAGRAM - HFW-2/6 & HFW-2/4 (CAP BULB THERMOSTAT CONFIGURATION)**

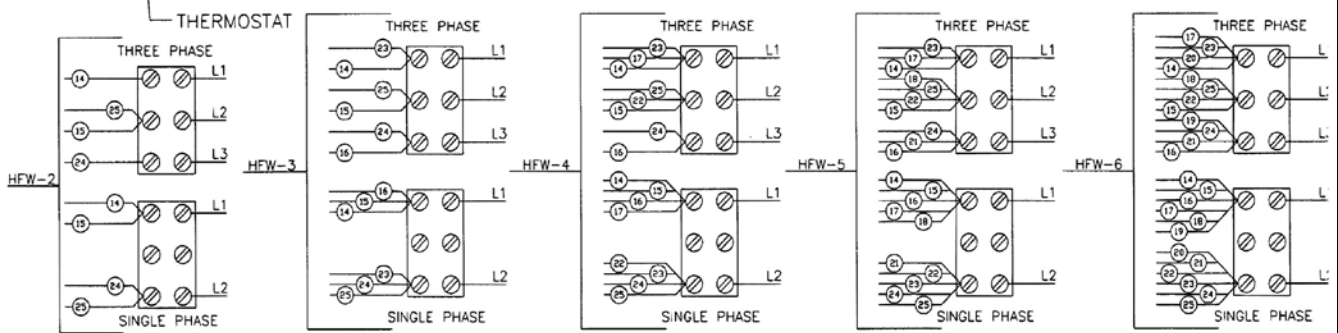
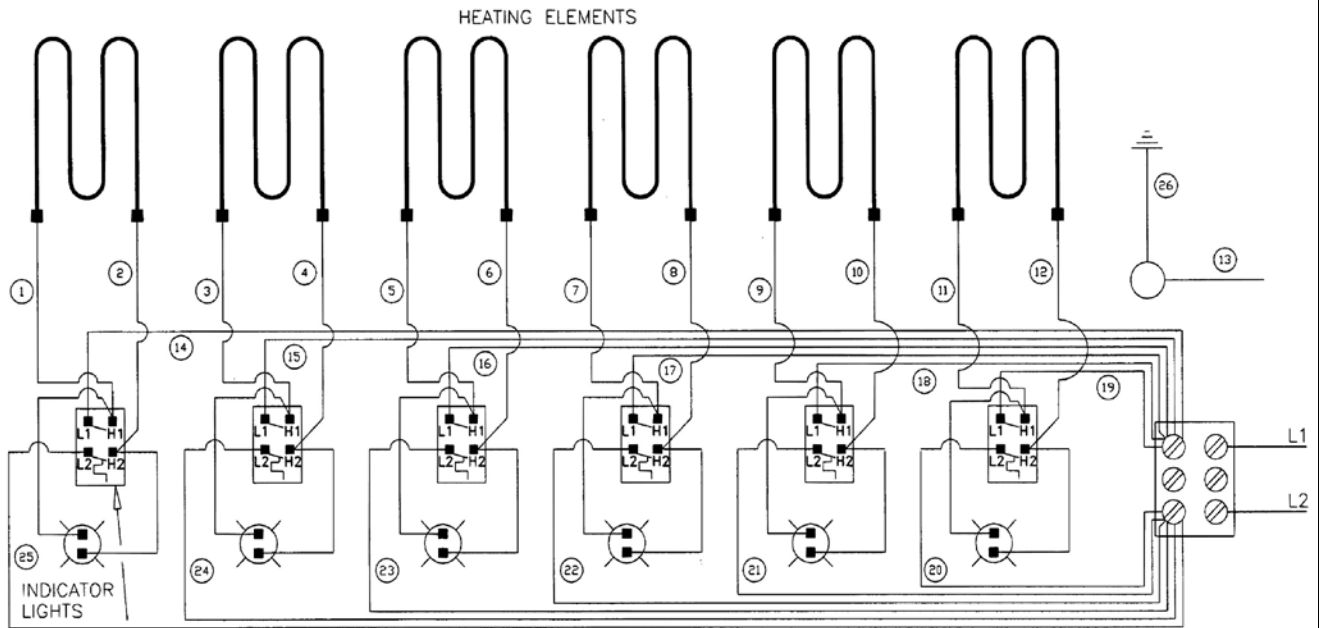

**WIRING DIAGRAM - HFW-2/6 & HFW-5-2/4 (CAP BULB INFINITE CONTROL CONFIGURATION)**

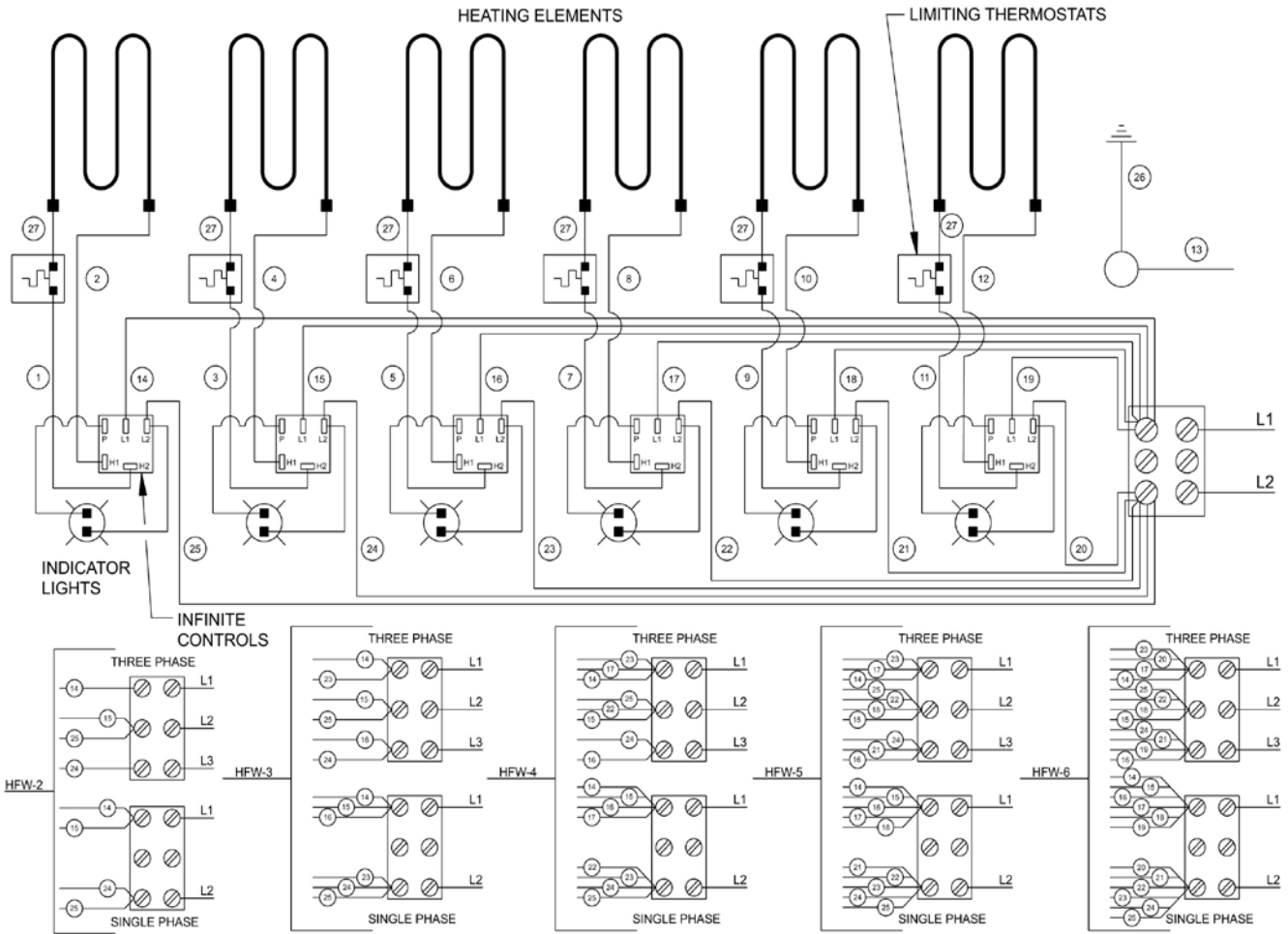



## APW Wyott EQUIPMENT LIMITED WARRANTY

APW Wyott Foodservice Equipment Company warrants its equipment against defects in materials and workmanship, subject to the following conditions:

This warranty applies to the original owner only and is not assignable.

Should any product fail to function in its intended manner under normal use within the limits defined in this warranty, at the option of APW Wyott such product will be repaired or replaced by APW Wyott or its Authorized Service Agency. APW Wyott will only be responsible for charges incurred or service performed by its Authorized Service Agencies. The use of other than APW Wyott Authorized Service Agencies will void this warranty and APW Wyott will not be responsible for such work or any charges associated with same. The closest APW Wyott Authorized Service Agent must be used.

This warranty covers products shipped into the 48 contiguous United States, Hawaii, metropolitan areas of Alaska and Canada. There will be no labor coverage for equipment located on any island not connected by roadway to the mainland.

Warranty coverage on products used outside the 48 contiguous United States, Hawaii, and metropolitan areas of Alaska and Canada may vary. Contact the international APW Wyott distributor, dealer, or service agency for details.

### Time Period

One year for parts and one year for labor, effective from the date of purchase by the original owner. The Authorized Service Agency may, at their option, require proof of purchase. Parts replaced under this warranty are warranted for the un-expired portion of the original product warranty only.

### Exceptions

- \* Gas/Electric Cookline: Models GCB, GCRB, GF, GGM, GGT, CHP-H, EF, EG, EHP. Three (3) Year Warranty on all component parts, except switches and thermostats. (2 additional years on parts only. No labor on second or third year.)
- \* Broiler Briquettes, Rock Grates, Cooking Grates, Burner Shields, Fireboxes: 90 Day Material Only. No Labor.
- \* Heat Strips: Models FD, FDL, FDD, FDDL. Two (2) Year Warranty on element only. No labor second year.
- \* Glass Windows, Doors, Seals, Rubber Seals, Light Bulbs: 90 Day Material Only. No Labor.

In all cases, parts covered by extended warranty will be shipped FOB the factory after the first year.

### Portable Carry In Products

Equipment weighing over 70 pounds or permanently installed will be serviced on-site as per the terms of this warranty. Equipment weighing 70 pounds or under, and which is not permanently installed, i.e. with cord and plug, is considered portable and is subject to the following warranty handling limitations. If portable equipment fails to operate in its intended manner on the first day of connection, or use, at APW Wyott's option or its Authorized Service Agency, it will be serviced on site or replaced.

From day two through the conclusion of this warranty period, portable units must be taken to or sent prepaid to the APW Wyott Authorized Service Agency for in-warranty repairs. No mileage or travel charges are allowed on portable units after the first day of use. If the customer wants on-site service, they may receive same by paying the travel and mileage charges. Exceptions to this rule: (1) countertop warmers and cookers, which are covered under the Enhanced Warranty Program, and (2) toasters or rollergrills which have in store service.

### Exclusions

The following conditions are not covered by warranty:

- \* Equipment failure relating to improper installation, improper utility connection or supply and problems due to ventilation.
- \* Equipment that has not been properly maintained, calibration of controls, adjustments, damage from improper cleaning and water damage to controls.
- \* Equipment that has not been used in an appropriate manner, or has been subject to misuse or misapplication, neglect, abuse, accident, alteration, negligence, damage during transit, delivery or installation, fire, flood, riot or act of god.
- \* Equipment that has the model number or serial number removed or altered.

If the equipment has been changed, altered, modified or repaired by other than an Authorized Service Agency during or after the warranty period, then the manufacturer shall not be liable for any damages to any person or to any property, which may result from the use of the equipment thereafter.

This warranty does not cover services performed at overtime or premium labor rates. Should service be required at times which normally involve overtime or premium labor rates, the owner shall be charged for the difference between normal service rates and such premium rates. APW Wyott does not assume any liability for extended delays in replacing or repairing any items beyond its control.

In all cases, the use of other than APW Wyott Authorized OEM Replacement Parts will void this warranty.

This equipment is intended for commercial use only. Warranty is void if equipment is installed in other than commercial application.

### Water Quality Requirements

Water supply intended for a unit that has in excess of 3.0 grains of hardness per gallon (GPG) must be treated or softened before being used. Water containing over 3.0 GPG will decrease the efficiency and reduce the operation life of the unit.

**Note: Product failure caused by liming or sediment buildup is not covered under warranty.**

**“THE FOREGOING WARRANTY IS IN LIEU OF ANY AND ALL OTHER WARRANTIES EXPRESSED OR IMPLIED INCLUDING ANY IMPLIED WARRANTY OF MERCHANTABILITY OR FITNESS FOR PARTICULAR PURPOSES AND CONSTITUTES THE ENTIRE LIABILITY OF APW WYOTT. IN NO EVENT DOES THE LIMITED WARRANTY EXTEND BEYOND THE TERMS STATED HEREIN.”**

9/05