

Heated Display Cases

Multi-Shelf Heated Display



ED2SYS-48/2S



ED2-48/2S



ED2SYS-72/2S



ED2-72/2S



ED2SYS-96/2S



ED2-96/2S

Models:

ED2-48/2S

ED2SYS-48/2S

ED2-72/2S

ED2SYS-72/2S

ED2-96/2S

ED2SYS-96/2S

- **INSTALLATION**
- **OPERATION**
- **MAINTENANCE**

W164 N9221 Water Street • P.O. Box 450
Menomonee Falls, Wisconsin 53052-0450 U.S.A.

PHONE: 262.251.3800 • 800.558.8744 U.S.A. / CANADA
FAX: 262.251.7067 • 800.329.8744 U.S.A. ONLY
www.alto-shaam.com



Consult instructions
for operation and use.



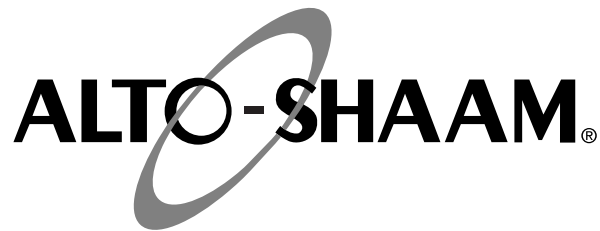

TABLE OF CONTENTS

Delivery	1
Unpacking	1
Safety Procedures and Precautions	2
Installation	
Installation Requirements	4
Clearance Requirements	4
Leveling	4
Cutting Board Installation	4
Dimension Drawings	5
Electrical Connection	6
Operating Instructions	
User Safety Information	7
Operating Procedures	8
General Holding Guidelines	9
Care and Cleaning	10
Cleaning and Preventative Maintenance	10
Preventative Maintenance Checklist	11
Equipment Care	13
Food Safety	14
Service	15
Countertop Assembly	15
Canopy Assembly	17
Shelf Assembly	18
Electrical Assembly	19
Base Assembly	20
Wire Diagrams	<i>Always refer to the wire diagram(s) included with the unit for most current version</i>
Warranty	
Transportation Damage and Claims	BACK COVER
Limited Warranty	BACK COVER



DELIVERY

This Alto-Shaam appliance has been thoroughly tested and inspected to ensure only the highest quality unit is provided. Upon receipt, check for any possible shipping damage and report it at once to the delivering carrier. *See Transportation Damage and Claims section located in this manual.*

This appliance, complete with unattached items and accessories, may be delivered in one or more packages. Ensure all standard items and options have been received with each model as ordered.

Save all the information packed with the appliance. Register online at www.alto-shaam.com to ensure prompt service in the event of a warranty parts and labor claim.

This manual must be read and understood by all people using or installing the equipment model. Contact the Alto-Shaam Tech Team Service Department if you have any questions concerning installation, operation, or maintenance.

1-800-558-8744; servicedept@alto-shaam.com

SERIAL NUMBER IS REQUIRED FOR ALL INQUIRIES

Always include both model and serial numbers in your correspondence regarding the unit.

Model: _____

Serial Number: _____

Purchased From: _____

Date Installed: _____ Voltage: _____

WARNING



Appliance and accessories may be heavy. To prevent serious injury, **ALWAYS** use a sufficient number of trained and experienced workers when moving or leveling appliance and handling accessories.

UNPACKING

- Carefully remove the appliance from the carton or crate.

NOTICE: Do not discard the carton and other packaging material until you have inspected the unit for hidden damage and tested it for proper operation.

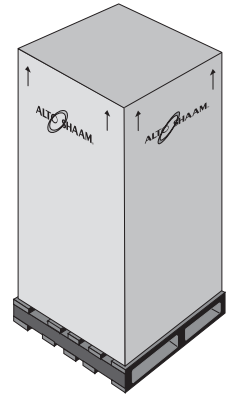

- Read all instructions in this manual carefully before installing this appliance, using the appliance or performing routine maintenance. Following procedures other than those indicated in this guide to use and clean the appliance is considered inappropriate and may cause damage, injury or fatal accidents, in addition to invalidating the guarantee and relieving Alto-Shaam of all liability.
- DO NOT DISCARD THIS MANUAL.** This manual is considered part of the appliance and is provided for the owner or manager of the business and for training personnel. *Additional manuals are available from the Alto-Shaam Tech Team Service Department.*
- Remove all protective plastic film, packaging materials, and accessories from the appliance before connecting electrical power. Store any accessories in a convenient place for future use.

ENVIRONMENTAL CONDITIONS

- Operational Environmental Conditions
- Unit must acclimate to room temperature in the environment it is placed. 24 hours is recommended.
- Ambient temperature range of 50° to 110°F (10° to 43°C).
- Relative humidity of less than 95% non-condensation.
- Atmospheric pressure range of 50KPa to 106KPa.

SAFETY PROCEDURES AND PRECAUTIONS

- This appliance is intended to hold foods for the purpose of human consumption. No other use for this appliance is authorized or recommended.
- This appliance is intended for use in commercial establishments where all operators are familiar with the purpose, limitations, and associated hazards of this appliance. Operating instructions and warnings must be read and understood by all operators and users. We recommend regular training of your staff to avoid the risk of accident or damage to the unit. Operators must also receive regular safety instructions.
- Any trouble shooting guides, component views, and parts lists included in this manual are for general reference only and are intended for use by qualified and trained technicians.
- This manual should be considered a permanent part of this appliance. This manual and all supplied instructions, diagrams, schematics, parts lists, notices, and labels must remain with the appliance if the item is sold or moved to another location.

Knowledge of proper procedures is essential to the safe operation of electrically and/or gas energized equipment. The following hazard signal words and symbols may be used throughout this manual.

DANGER



Used to indicate the presence of a hazard that **WILL** cause severe personal injury, death, or substantial property damage if the warning included with this symbol is ignored.

WARNING



Used to indicate the presence of a hazard that **CAN** cause personal injury, possible death, or major property damage if the warning included with this symbol is ignored.

CAUTION



Used to indicate the presence of a hazard that can or will cause minor or moderate personal injury or property damage if the warning included with this symbol is ignored.

CAUTION

Used to indicate the presence of a hazard that can or will cause minor personal injury, property damage, or a potential unsafe practice if the warning included with this symbol is ignored.

NOTICE: Used to notify personnel of installation, operation, or maintenance information that is important but not hazard related.



Used to indicate that referral to operating instructions is a mandatory action. If not followed the operator could suffer personal injury.



Used to indicate that referral to operating instructions is recommended to understand operation of equipment.

NOTICE: For equipment delivered for use in any location regulated by the following directive:



DO NOT dispose of electrical or electronic equipment with other municipal waste.

ADDITIONAL SAFETY PROCEDURES AND PRECAUTIONS

- To prevent serious injury, death or property damage, your appliance should be inspected and serviced at least every twelve (12) months by an authorized service partner or trained technician.
- ONLY allow an authorized service partner or trained technician to service or to repair your appliance. Installation or repairs that are not performed by an authorized service partner or trained technician, or the use of non-factory authorized parts will void the warranty and relieve Alto-Shaam of all liability.
- When working on this appliance, observe precautions in the literature, on tags, on labels attached to or shipped with the appliance and other safety precautions that may apply.

WARNING



This appliance is not intended for use by persons (including children) with reduced physical, sensory or mental capabilities, or lack of experience and knowledge, unless they have been given supervision concerning use of the appliance by person responsible for their safety.

Children should be supervised to ensure that they do not play with the appliance.

WARNING



If the appliance is not cleaned or is not cleaned well enough, deposits of grease and or food residues inside the appliance may catch fire. If fat deposits and/or food waste inside the appliance ignite disconnect the appliance from the main power and use a fire extinguisher (do not use water to extinguish a grease fire!). Failure to clean the appliance properly may cause fire, personal injury, death, invalidates the warranty and relieves Alto-Shaam of all liability.

WARNING



Improper installation, alteration, adjustment, service, cleaning, or maintenance could result in property damage, severe injury, or death.

READ and UNDERSTAND the installation, operating and maintenance instructions thoroughly before installing, servicing, or operating this equipment.

WARNING



Appliance and accessories may be heavy. To prevent serious injury, ALWAYS use a sufficient number of trained and experienced workers when moving or leveling appliance and handling accessories.

CAUTION



To prevent SEVERE PERSONAL INJURY or PROPERTY DAMAGE:

ALWAYS use hand protection when operating this appliance to avoid burns. Metal parts of this equipment become extremely hot when in operation.

INSTALLATION

SITE INSTALLATION

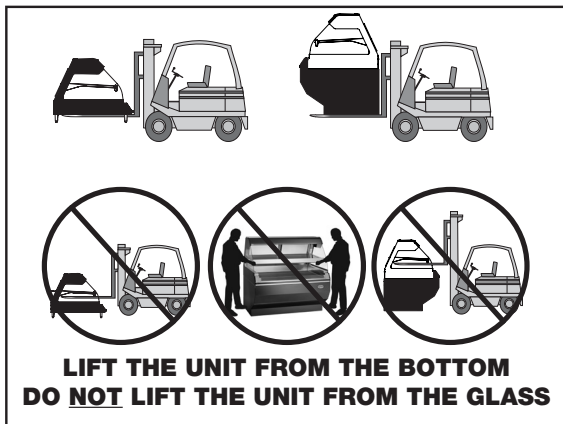

1. Care must be taken when moving this unit into place because of its glass components.
2. **DO NOT** install this appliance in any area where it may be affected by any adverse conditions such as steam, grease, dripping water, high temperatures, or any other severely adverse conditions.
3. **DO NOT** install a heated display case near a cold air source such as a freezer, air conditioning vents, or in any area where outside air fluctuation can affect performance.
4. The appliance must be installed on a stable and level surface.
5. In order to maintain established National Sanitation Foundation standards, all stationary floor models must be sealed to the floor with a R.T.V. or silastic meeting N.S.F. requirements or have 6" (152mm) unobstructed clearance beneath the unit.
6. This appliance must be kept free and clear of any obstructions blocking access for maintenance or service.

A number of adjustments are associated with initial installation and start-up. It is important that these adjustments be conducted by a qualified service technician. Installation and start-up adjustments are the responsibility of the dealer or user. These adjustments include but are not limited to thermostat calibration, door adjustment, leveling, electrical hook-up and installation of optional casters or legs.

LEVELING

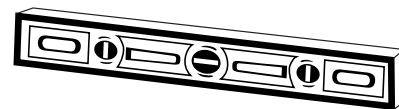

Level the appliance from side-to-side and front-to-back with the use of a spirit level.

We recommend checking the level periodically to make certain the floor has not shifted nor the appliance moved.

NOTICE: Failure to properly level this appliance can cause improper function.

MINIMUM CLEARANCE REQUIREMENTS

Counter and table units must be mounted on legs of a sufficient 4" (102mm) height to provide minimum unobstructed space beneath the unit. These legs are supplied with the unit. Warranty will become null and void if these directions are not followed.

Cutting board installation:

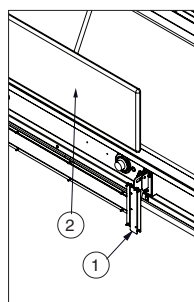

1. Place both brackets in the closed (down) position.
2. Slide cutting board back flanges down onto brackets.
3. Pivot installed board to a horizontal position and slide bracket down to lock in the open position. (NOT SHOWN)

INSTALLATION

SITE INSTALLATION

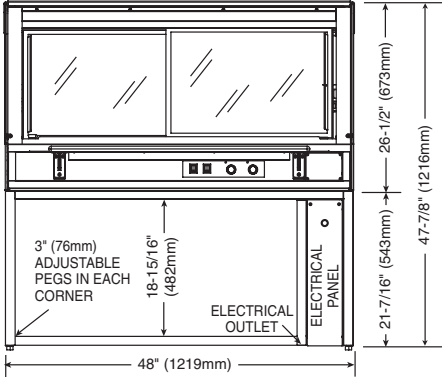

ED2SYS-48/2S

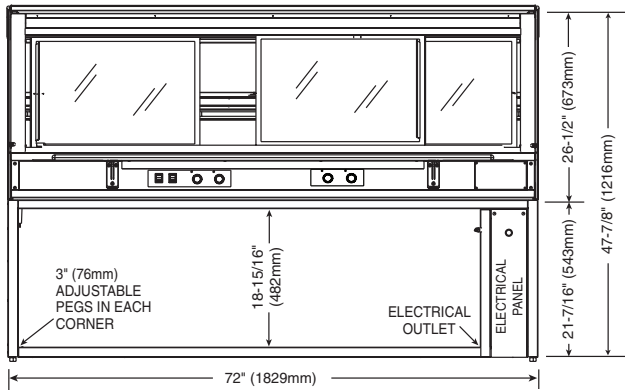

ED2SYS-72/2S

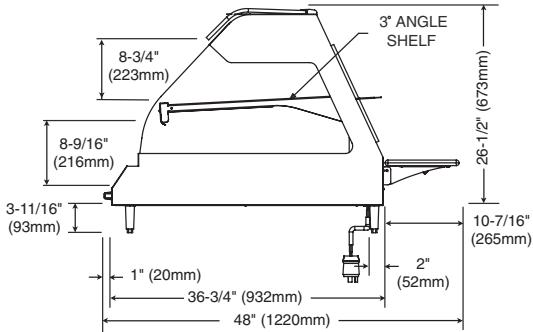

ED2-2S PROFILE

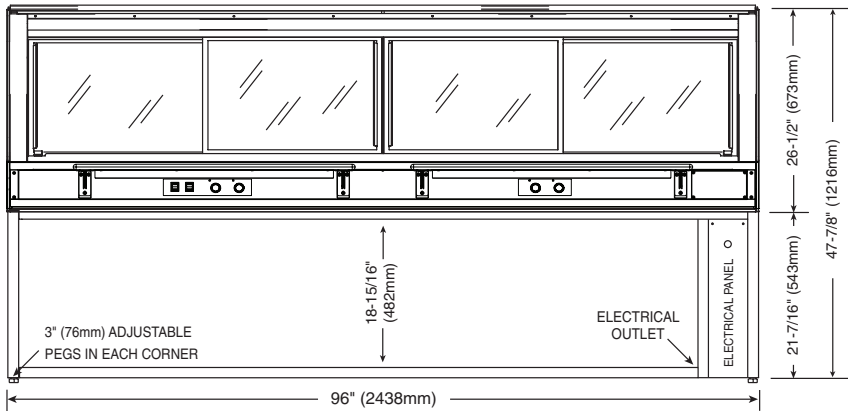

ED2SYS-96/2S

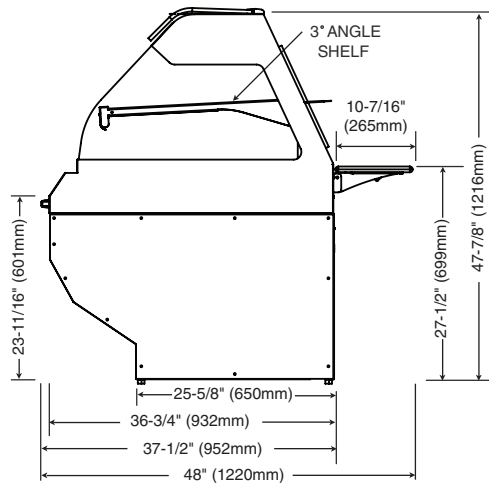

ED2SYS-2S PROFILE

INSTALLATION

ELECTRICAL CONNECTION

DANGER



Ensure power source matches voltage identified on appliance rating tag. The rating tag provides essential technical information required for any appliance installation, maintenance or repairs. Do not remove, damage or modify the rating tag.

WARNING



To prevent **SERIOUS INJURY, DEATH, or PROPERTY DAMAGE:**

All electrical connections must be made by a qualified and trained service technician in accordance with applicable electrical codes.



This appliance **MUST** be adequately grounded in accordance with local electrical codes or, in the absence of local codes, with the current edition of the National Electrical Code ANSI/NFPA No. 70. In Canada, all electrical connections are to be made in accordance with CSA C22.1, Canadian Electrical Code Part 1 or local codes.

WARNING



To prevent **SERIOUS INJURY, DEATH or PROPERTY DAMAGE:**

All electrical connections must be made by a qualified and trained service technician in accordance with applicable electrical codes.

Plug the unit into a properly grounded receptacle **ONLY**, positioning the unit so that the plug is easily accessible in case of an emergency. Arcing will occur when connecting or disconnecting the unit unless all controls are in the "OFF" position.

REGARDING INTERNATIONAL STANDARD UNITS:

If the unit is not equipped with flexible cord and plug, an all-pole country approved disconnection device which has a contact separation of at least 3mm in all poles must be incorporated in the fixed wiring for disconnection. When using a cord without a plug, the green/yellow conductor shall be connected to the terminal which is marked with the ground symbol. If a plug is used, the socket outlet must be easily accessible. If the power cord needs replacement, use a similar one obtained from the distributor.

For CE approved units: To prevent an electrical shock hazard between the appliance and other appliances or metal parts in close vicinity, an equalization-bonding stud is provided. An equalization bonding lead must be connected to this stud and the other appliances/metal parts to provide sufficient protection against potential difference. The terminal is marked with the following symbol.







Hard wired models:

Hard wired models must be equipped with a country certified external allpole disconnection switch with sufficient contact separation.

If a power cord is used for the connection of the product an oil resistant cord like H05RN or H07RN or equivalent must be used.

NOTICE: Where local codes and CE regulatory requirements apply, appliances must be connected to an electrical circuit that is protected by an external GFCI outlet.

ED2/2S SERIES ELECTRICAL						
48/2S Series						
VOLTAGE	PHASE	CYCLE/HZ	AMPS	kW		
208-240	1	50/60	11.7	2.8	NEMA 6-20P 20A, 250V PLUG	
208	1	50/60	10.0	2.1	(PLUG - COUNTERTOP ONLY; BARE END, NO PLUG - SYSTEM)	
240	1	50/60	11.7	2.8		
230	1	50/60	11.0	2.6	CEE 7/7 220-230V PLUG	
(PLUG - COUNTERTOP ONLY; BARE END, NO PLUG - SYSTEM)						
72/2S Series						
VOLTAGE	PHASE	CYCLE/HZ	AMPS	kW		
208-240	1	50/60	17.9	4.5	NEMA L6-30P 30A, 250V PLUG	
208	1	50/60	17.1	3.4	(PLUG - COUNTERTOP ONLY; BARE END, NO PLUG - SYSTEM)	
240	1	50/60	17.9	4.5		
96/2S Series						
VOLTAGE	PHASE	CYCLE/HZ	AMPS	kW		
208-240	1	50/60	21.8	5.2	NEMA L6-30P 30A, 250V PLUG	
208	1	50/60	20.2	4.0	(PLUG - COUNTERTOP ONLY; BARE END, NO PLUG - SYSTEM)	
240	1	50/60	21.8	5.2		

OPERATING INSTRUCTIONS

USER SAFETY INFORMATION

DANGER



To prevent **SERIOUS PERSONAL INJURY, DEATH, or PROPERTY DAMAGE**:

DO NOT steam clean, hose down or flood the interior or exterior with water or liquid solution of any kind. **DO NOT** use water jet to clean.

Failure to observe this precaution will void the warranty.



This appliance is intended for use in commercial establishments where all operators are familiar with the purpose, limitations, and associated hazards of this appliance. Operating instructions and warnings must be read and understood by all operators and users.

BEFORE INITIAL USE:

Before operating, clean with a damp cloth and mild soap solution. Glass cleaner can be used on the glass.

SPECIAL INSTRUCTIONS:

- 1. DO NOT** allow liquids or food to come in direct contact with the glass shelves.
- Use hand protection when handling hot items.
- Be certain only hot foods in appropriate heat tested containers are used.
- It is recommended that plastic or paper containers be used. Pans or dishes will scratch the glass.
- Be careful not to overheat as this may cause some containers to melt.
- 6. DO NOT** stack containers.

WARNING

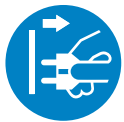

To prevent **SERIOUS INJURY, DEATH, OR PROPERTY DAMAGE**, **ALWAYS** disconnect unit from power source before cleaning or servicing.

HEATING CHARACTERISTICS

The heated upper glass surface provides even heat transfer to hot food in heat tested containers that are held in direct contact with the glass top.

CAUTION



To prevent **SEVERE PERSONAL INJURY or PROPERTY DAMAGE**:

ALWAYS use hand protection when operating this appliance to avoid burns. Metal parts of this equipment become extremely hot when in operation.

To avoid personal injury and damage to the unit, treat glass with care. Remember -- glass can shatter.

PRODUCT CAPACITY

ED2-48/2S; ED2SYS-48/2S

TOP SHELF

Twelve (12) chicken boats with dome cover

BOTTOM SHELF

Fifteen (15) chicken boats with dome cover

ED2-72/2S; ED2SYS-72/2S

TOP SHELF

Eighteen (18) chicken boats with dome cover

BOTTOM SHELF

Twenty-one (21) chicken boats with dome cover

ED2-96/2S; ED2SYS-96/2S

TOP SHELF

Twenty-four (24) chicken boats with dome cover

BOTTOM SHELF

Thirty (30) chicken boats with dome cover

OPERATING INSTRUCTIONS

OPERATING PROCEDURES

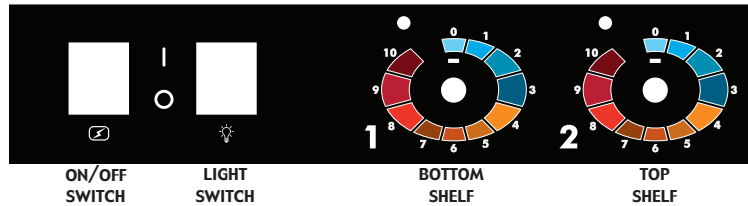

- 1. Check that the unit is connected to the appropriate power source.**
- 2. Turn thermostat(s) to a predetermined number and preheat for 30 minutes.**

Each shelf has its own thermostat control numbering from 0 to 10. When the thermostat is turned clockwise to the determined number, the indicator light will illuminate and will remain lit as long as the shelf is calling for heat.

The indicator light will go OUT when the temperature on the glass top reaches the set number determined by the operator. It will then cycle "on/off" at this holding point.

The shelves will hold a steady even heat as assigned. The user must determine what set point can be used regarding each food item held on its corresponding shelf. It is recommended that a similar food product be placed on each shelf.

The proper temperature range for the food being held will depend on the food type, the packaging, and the quantity of product. When holding food for prolonged periods, it is advisable to periodically check the internal temperature of each item to assure maintenance of the proper temperature range.

- 3. Load prepackaged hot foods into the display case.**

Before loading food into the unit, use a pocket-type meat thermometer to make certain all products have reached an internal temperature of 160°F (71°C) or higher. If any food product is not at proper serving temperature, use a Halo Heat® cooking and holding oven or Combitherm® Oven to bring the product within the correct temperature range.

- 4. Occasionally rotate foods as needed.**

Wipe spills immediately to assure maximum eye appeal and minimize end-of-the-day cleanup.

- 5. Keep display case doors closed after serving.**

OPERATING INSTRUCTIONS

GENERAL HOLDING GUIDELINES

Chefs, cooks and other specialized food service personnel employ varied methods of cooking. Proper holding temperatures for a specific food product must be based on the moisture content of the product, product density, volume, and proper serving temperatures. Safe holding temperatures must also be correlated with palatability in determining the length of holding time for a specific product.

Halo Heat maintains the maximum amount of product moisture content without the addition of water, water vapor, or steam. Maintaining maximum natural product moisture preserves the natural flavor of the product and provides a more genuine taste. In addition to product moisture retention, the gentle properties of Halo Heat maintain a consistent temperature throughout the cabinet without the necessity of a heat distribution fan, thereby preventing further moisture loss due to evaporation or dehydration.

When product is removed from a high temperature cooking environment for immediate transfer into equipment with the lower temperature required for hot food holding, condensation can form on the outside of the product and on the inside of plastic containers used in self-service applications. Allowing the product to release the initial steam and heat produced by high temperature cooking can alleviate this condition. To preserve the safety and quality of freshly cooked foods however, a maximum of 1 to 2 minutes must be the only time period allowed for the initial heat to be released from the product.

The unit is equipped with a thermostat indicating a range of between 1 and 10. Use a metal-stemmed indicating thermometer to measure the internal temperature of the product(s) being held. Adjust the thermostat setting to achieve the best overall setting based on internal product temperature.

HOLDING TEMPERATURE RANGE		
MEAT	FAHRENHEIT	CELSIUS
BEEF ROAST — Rare	130°F	54°C
BEEF ROAST — Med/Well Done	155°F	68°C
BEEF BRISKET	160°F — 175°F	71°C — 79°C
CORN BEEF	160°F — 175°F	71°C — 79°C
PASTRAMI	160°F — 175°F	71°C — 79°C
PRIME RIB — Rare	130°F	54°C
STEAKS — Broiled/Fried	140°F — 160°F	60°C — 71°C
RIBS — Beef or Pork	160°F	71°C
VEAL	160°F — 175°F	71°C — 79°C
HAM	160°F — 175°F	71°C — 79°C
PORK	160°F — 175°F	71°C — 79°C
LAMB	160°F — 175°F	71°C — 79°C
POULTRY		
CHICKEN — Fried/Baked	160°F — 175°F	71°C — 79°C
DUCK	160°F — 175°F	71°C — 79°C
TURKEY	160°F — 175°F	71°C — 79°C
GENERAL	160°F — 175°F	71°C — 79°C
FISH/SEAFOOD		
FISH — Baked/Fried	160°F — 175°F	71°C — 79°C
LOBSTER	160°F — 175°F	71°C — 79°C
SHRIMP — Fried	160°F — 175°F	71°C — 79°C
BAKED GOODS		
BREADS/ROLLS	120°F — 140°F	49°C — 60°C
MISCELLANEOUS		
CASSEROLES	160°F — 175°F	71°C — 79°C
DOUGH — Proofing	80°F — 100°F	27°C — 38°C
EGGS — Fried	150°F — 160°F	66°C — 71°C
FROZEN ENTREES	160°F — 175°F	71°C — 79°C
HORS D'OEUVRES	160°F — 180°F	71°C — 82°C
PASTA	160°F — 180°F	71°C — 82°C
PIZZA	160°F — 180°F	71°C — 82°C
POTATOES	180°F	82°C
PLATED MEALS	140°F — 165°F	60°C — 74°C
SAUCES	140°F — 200°F	60°C — 93°C
SOUP	140°F — 200°F	60°C — 93°C
VEGETABLES	160°F — 175°F	71°C — 79°C
THE HOLDING TEMPERATURES LISTED ARE SUGGESTED GUIDELINES ONLY. ALL FOOD HOLDING SHOULD BE BASED ON INTERNAL PRODUCT TEMPERATURES. ALWAYS FOLLOW LOCAL HEALTH (HYGIENE) REGULATIONS FOR ALL INTERNAL TEMPERATURE REQUIREMENTS.		

CARE AND CLEANING

CLEANING AND PREVENTATIVE MAINTENANCE

WARNING



If the appliance is not cleaned or is not cleaned well enough, deposits of grease and or food residues inside the appliance may catch fire. If fat deposits and/or food waste inside the appliance ignite disconnect the appliance from the main power and use a fire extinguisher (do not use water to extinguish a grease fire!). Failure to clean the appliance properly may cause fire, personal injury, death, invalidates the warranty and relieves Alto-Shaam of all liability.

CAUTION



To protect stainless steel surfaces, completely avoid the use of abrasive cleaning compounds, chloride based cleaners, or cleaners containing quaternary salts. **NEVER** use hydrochloric acid (muriatic acid) on stainless steel. **NEVER** use wire brushes, metal scouring pads or scrapers.

PROTECTING STAINLESS STEEL SURFACES



It is important to guard against corrosion in the care of stainless steel surfaces. Harsh, corrosive, or inappropriate chemicals can completely destroy the protective surface layer of stainless steel. Abrasive pads, steel wool, or metal implements will abrade surfaces causing damage to this protective coating and will eventually result in areas of corrosion. Even water, particularly hard water that contains high to moderate concentrations of chloride, will cause oxidation and pitting that result in rust and corrosion. In addition, many acidic foods spilled and left to remain on metal surfaces are contributing factors that will corrode surfaces.

Proper cleaning agents, materials, and methods are vital to maintaining the appearance and life of this appliance. Spilled foods should be removed and the area wiped as soon as possible but at the very least, a minimum of once a day. Always thoroughly rinse surfaces after using a cleaning agent and wipe standing water as quickly as possible after rinsing.

CLEANING AGENTS

Use non-abrasive cleaning products designed for use on stainless steel surfaces. Cleaning agents must be chloride-free compounds and must not contain quaternary salts. Never use hydrochloric acid (muriatic acid) on stainless steel surfaces. Always use the proper cleaning agent at the manufacturer's recommended strength. Contact your local cleaning supplier for product recommendations.

CLEANING MATERIALS

The cleaning function can usually be accomplished with the proper cleaning agent and a soft, clean cloth. When more aggressive methods must be employed, use a non-abrasive scouring pad on difficult areas and make certain to scrub with the visible grain of surface metal to avoid surface scratches. Never use wire brushes, metal scouring pads, or scrapers to remove food residue.

CARE AND CLEANING

PREVENTATIVE MAINTENANCE CHECKLIST

SERIAL NUMBER IS REQUIRED FOR ALL INQUIRIES

Always include both model and serial numbers in your correspondence regarding the unit.

Company: _____

Model: _____

Serial Number: _____

Purchased From: _____

Date Installed: _____ Voltage: _____

Inspection Date: _____

DAILY CHECK LIST:

- Clean the display case and glass as detailed in this manual.

WEEKLY CHECK LIST:

- Tighten and inspect light bulbs.

MONTHLY CHECK LIST:

- Inspect end and front glass pieces for any signs of chips and cracks.
 - Schedule service immediately if a crack or chip is noted.
- Test gas struts (full service cases only).
 - Lift the front glass fully.
 - Ensure glass remains suspended without dropping back down.
 - If struts are not holding the glass in an upright position, schedule service as soon as possible.

COMPONENT FAILURE & REPLACEMENT

List details of the failure(s) with the date they occurred. (Leave blank if components are working properly)

Component: _____	Date (MM/DD/YY): _____
Component: _____	Date (MM/DD/YY): _____
Component: _____	Date (MM/DD/YY): _____
Component: _____	Date (MM/DD/YY): _____
Component: _____	Date (MM/DD/YY): _____
Component: _____	Date (MM/DD/YY): _____
Component: _____	Date (MM/DD/YY): _____

CARE AND CLEANING

PREVENTATIVE MAINTENANCE CHECKLIST

SERIAL NUMBER IS REQUIRED FOR ALL INQUIRIES

Always include both model and serial numbers in your correspondence regarding the unit.

Company: _____

Model: _____

Serial Number: _____

Purchased From: _____

Date Installed: _____ Voltage: _____

Inspection Date: _____

EVERY 12 MONTHS CHECK LIST:

Inspection by a factory authorized technician.

- Open control panel and inspect/tighten all wiring.
- Inspect all electrical components.
- Test elements for electrical short to ground. Replace/repair as needed.
- Remove top cover and inspect light wiring and light receptacles. Repair/replace as needed.
- Visually inspect the well and the well surface for any indications of cracking, deterioration, distortion or misuse.
- Replace end glass gasket.
- Inspect handle gasket. Replace as needed.
- Replace sliding glass door gaskets.
- Inspect glass alignment.
- Inspect glass clamp and glass position in clamp. Tighten/replace as needed.
- Inspect any customer bumper material. Replace as needed.
- Perform thermostat calibration based on factory recommended procedures.

COMPONENT FAILURE & REPLACEMENT

Note any component failure(s) that was discovered during this twelve month inspection.
(Leave blank if components are working properly)

CARE AND CLEANING

DANGER



To prevent **SERIOUS PERSONAL INJURY, DEATH, or PROPERTY DAMAGE**:

DO NOT steam clean, hose down or flood the interior or exterior with water or liquid solution of any kind. **DO NOT** use water jet to clean.

Failure to observe this precaution will void the warranty.

WARNING

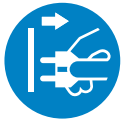

To prevent **SERIOUS INJURY, DEATH, OR PROPERTY DAMAGE**, **ALWAYS** disconnect unit from power source before cleaning or servicing.

CAUTION



The performance of this unit has been optimized using the factory provided bulbs. These bulbs should be replaced with an exact replacement or with a factory recommended replacement. These bulbs have been treated to resist breakage and must be replaced with similarly treated bulbs in order to maintain compliance with NSF standards. **DO NOT** over-tighten bulbs in their receptacles as this may cause damage to the bulb filament.

CLEAN THE UNIT THOROUGHLY AFTER EACH USE

1. Turn lights and adjustable thermostat(s) to the "OFF" position. Disconnect unit from power source, and let cool.
2. Remove, cover or wrap, and store food product under refrigeration.
3. **DO NOT clean the glass when hot.** The glass should be cleaned regularly with fresh warm water, a mild detergent, and a clean, non-abrasive cloth. Glass cleaner can be used.
4. Clean interior with a damp cloth or sponge and any good commercial detergent at the recommended strength.
5. The aluminum plate shelves have a clear coat anodized surface that must be cleaned with a multi-purpose cleaner to avoid distortion and deterioration of the surface. First test the cleaner on a small portion of the plate in an inconspicuous corner of the shelf before proceeding.
6. Spray heavily soiled areas with a water soluble degreaser and let stand for 10 minutes, then remove soil with a plastic scouring pad.

NOTICE: Never use abrasive cleaning compounds, chloride based cleaners, or cleaners containing quaternary salts. Never use hydrochloric acid (muriatic acid) on stainless steel.



7. Clean control panel, vents, handles, and gaskets thoroughly since these areas harbor food debris.
8. Rinse surfaces by wiping with sponge and clean warm water.
9. Remove excess water with sponge and wipe dry with a clean cloth or air dry.
10. Interior can be wiped with a sanitizing solution after cleaning and rinsing. This solution must be approved for use on food contact surfaces.
11. To help maintain the protective film coating on any polished stainless steel, clean the exterior of the cabinet with a cleaner recommended for stainless steel surfaces. Spray the cleaning agent on a clean cloth and wipe with the grain of the stainless steel.

Always follow appropriate state or local health (hygiene) regulations regarding all applicable cleaning and sanitation requirements for foodservice equipment.

FOOD SAFETY

Food flavor and aroma are usually so closely related that it is difficult, if not impossible, to separate them. There is also an important, inseparable relationship between cleanliness and food flavor. Cleanliness, top operating efficiency, and appearance of equipment contribute considerably to savory, appetizing foods.

Most food imparts its own particular aroma and many foods also absorb existing odors. Unfortunately, during this absorption there is not a distinction between GOOD and BAD odors. The majority of objectionable flavors and odors troubling food service operations are caused by bacteria growth. Sourness, rancidity, mustiness, stale or other OFF flavors are usually the result of germ activity.

The easiest way to ensure full, natural food flavor is through comprehensive cleanliness. This means good control of both visible soil (dirt) and invisible soil (germs). A thorough approach to sanitation will provide essential cleanliness. It will ensure an attractive appearance of equipment, along with maximum efficiency and utility. More importantly, a good sanitation program provides one of the key elements in the prevention of food-borne illnesses.

A comprehensive sanitation program should focus on the training of staff in basic sanitation procedures. This includes personal hygiene, proper handling of raw foods, cooking to a safe internal product temperature, and the routine monitoring of internal temperatures from receiving through service.

A controlled holding environment for prepared foods is just one of the important factors involved in the prevention of food-borne illnesses. Temperature monitoring and control during receiving, storage, preparation, and the service of foods are of equal importance.

The most accurate method of measuring safe temperatures of both hot and cold foods is by internal product temperature. A quality thermometer is an effective tool for this purpose, and should be routinely used on all products that require holding at a specific temperature.

INTERNAL FOOD PRODUCT TEMPERATURES		
HOT FOODS		
DANGER ZONE	40°F TO 140°F	(4°C TO 60°C)
CRITICAL ZONE	70°F TO 120°F	(21°C TO 49°C)
SAFE ZONE	140°F TO 165°F	(60°C TO 74°C)
COLD FOODS		
DANGER ZONE	ABOVE 40°F	(ABOVE 4°C)
SAFE ZONE	36°F TO 40°F	(2°C TO 4°C)
FROZEN FOODS		
DANGER ZONE	ABOVE 32°F	(ABOVE 0°C)
CRITICAL ZONE	0°F TO 32°F	(-18°C TO 0°C)
SAFE ZONE	0°F or below	(-18°C or below)

Hazard Analysis (at) Critical Control Points (HACCP), is a quality control program of operating procedures to assure food integrity, quality, and safety. Taking steps necessary to augment food safety practices is both cost effective and relatively simple. Additional HACCP information is available by contacting:

*Center for Food Safety and Applied Nutrition
Food and Drug Administration
PHONE: 1-888-SAFEFOOD
www.foodsafety.gov*

COUNTERTOP (ED2-96/2S SHOWN)

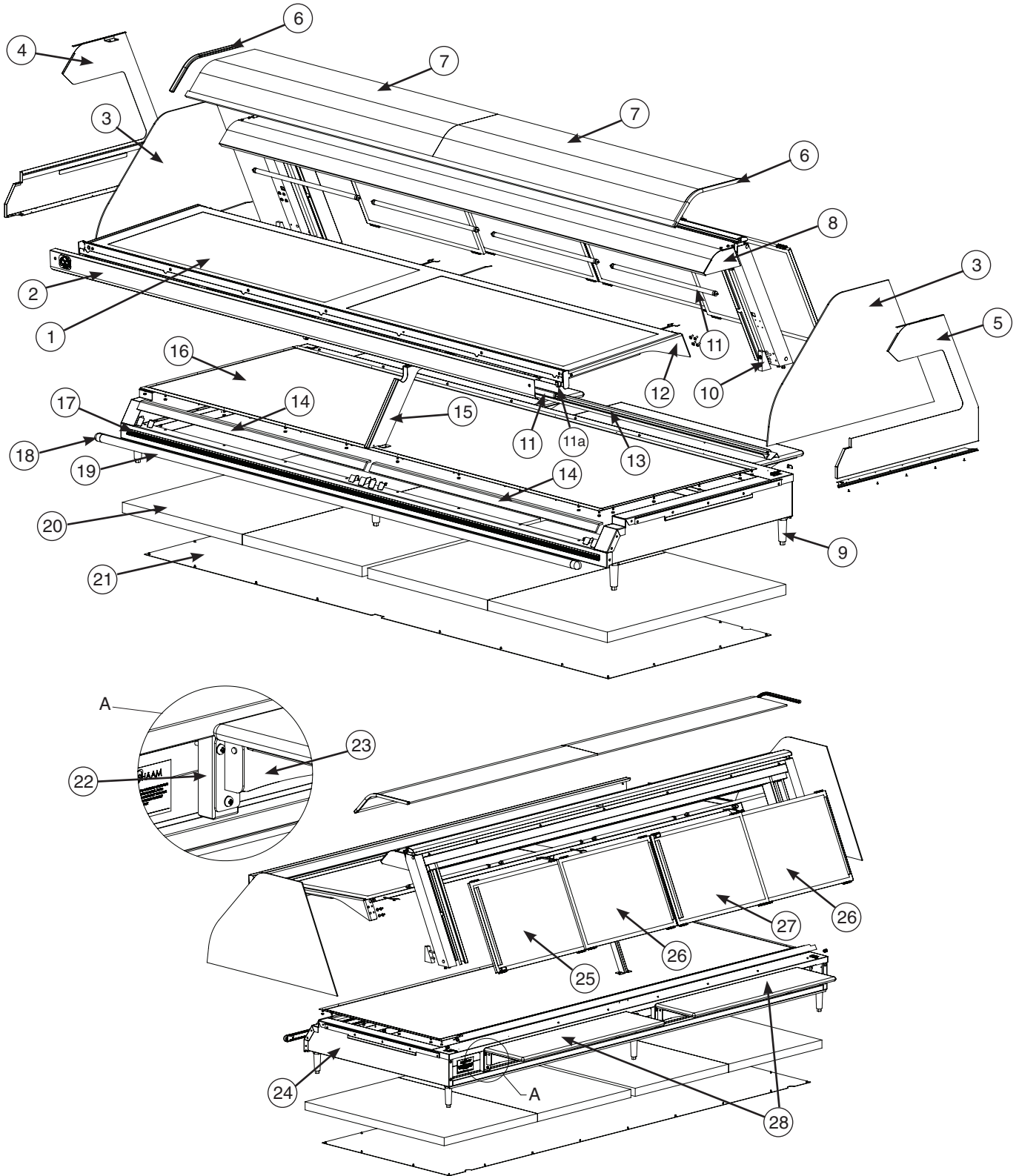

Part numbers and drawings are subject to change without notice.

SERVICE

COUNTERTOP (ED2-96/2S SHOWN)

*NOT SHOWN

MODEL >		ED2(SYS)-48/2S*		ED2(SYS)-72/2S*		ED2(SYS)-96/2S	
ITEM	DESCRIPTION	PART NO.	QTY	PART NO.	QTY	PART NO.	QTY
1	SHELF ASSEMBLY (SEE PAGE 18)	5004203	1	5004097	1	5004238	1
2	SHELF FRONT COVER	1005155	1	1005053	1	1005194	1
3	GLASS, END	GL-25762	2	GL-25762	2	GL-25762	2
4	GLASS COVER, LH (BLK)	5001726	1	5001726	1	5001726	1
	GLASS COVER, LH (S/S)	5005470	2	5005470	2	5005470	2
5	GLASS COVER, RH (BLK)	5001725	1	5001725	1	5001725	1
	GLASS COVER, RH (S/S)	5005469	1	5005469	1	5005469	1
6	GASKET, END GLASS	GS-22547	2	GS-22547	2	GS-22547	2
7	GLASS, CURVED	GL-26028	1	GL-26773	1	GL-26028	2
8	CANOPY ASSEMBLY	5001752	1	5003763	1	5004232	1
9	LEG, 4" (102mm)	LG-2044	4	LG-2044	4	LG-2044	6
10	UPRIGHT WEDGE	BK-26025	2	BK-26025	2	BK-26025	2
11	LAMPS, FLORESCENTS, SOFT WHITE, T5, 13W	LP-33822	4	LP-33822	6	LP-33822	8
11a	RECEPTACLE, FLORESCENT, LIGHT	RP-34160	4	RP-34160	6	RP-34160	8
12	SHELF SUPPORT BRACKET, RH	1005054	1	1005054	1	1005054	1
	SHELF SUPPORT BRACKET, LH	1005055	1	1005055	1	1005055*	1
13	BOTTOM DOOR TRACK	TK-26751	1	TK-26859	1	TK-27861	1
14	GUARD, LEXAN	GD-27170	1	GD-27171	2	GD-27172	2
15	SHELF SUPPORT WELD	—	—	5004592	1	5004592	1
16	ALUMINUM HEAT PLATE ASSEMBLY	5001730	1	5003762	1	5004215	1
17	BUMPER TRACK	1011790	1	1011792	1	1011796	1
18	BUMPER, RAIL, END CAP	BM-29354	2	BM-29354	2	BM-29354	2
19	BUMPER, 4ft (1219mm)	1011791	1	—	—	—	—
	BUMPER, 6ft (1829mm)	—	—	1011793	1	—	—
	BUMPER, 8ft (2438mm)	—	—	—	—	1011797	1
20	INSULATION, 6ft ² (557,418mm ²)	IN-22364	2	IN-22364	4	IN-22364	4
21	PANEL, COVER, BOTTOM	1002499	1	1004183	1	1005183	1
22	BRACKET, CUTTING BOARD	11283	2	11283	2	11283	4
23	CUTTING BOARD BRACKET	BT-2342	2	BT-2342	2	BT-2342	4
24	WELL BASE ASSEMBLY (BLK)	5001715	1	5003761	1	5004214	1
	WELL BASE ASSEMBLY (S/S)	5005551	1	5005781	1	5005980	1
25	DOOR, GLASS, LH	DR-25422	1	DR-25422	1	DR-25422	1
26	DOOR, GLASS, MIDDLE	DR-25423	1	DR-25423	1	DR-25423	2
27	DOOR, GLASS, RH	—	—	DR-25424	1	DR-25424	1
28	CUTTING BOARD ASSEMBLY, 4ft (1219mm)	4016	1	—	—	4016	2
	CUTTING BOARD ASSEMBLY, 6ft (1829mm)	—	—	4017	1	—	—

Part numbers and drawings are subject to change without notice.

CANOPY ASSEMBLY (ED2(SYS)-96/2S - 5004232 - SHOWN)

*NOT SHOWN

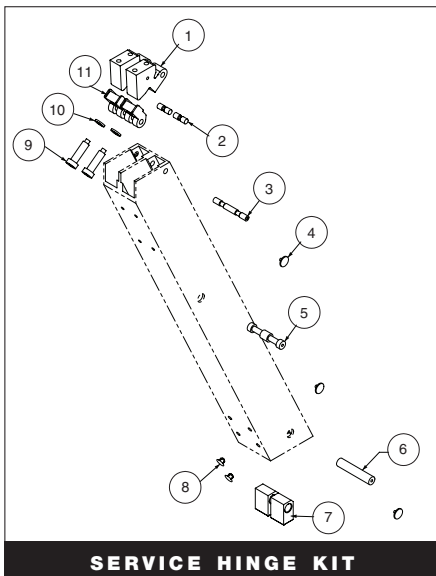
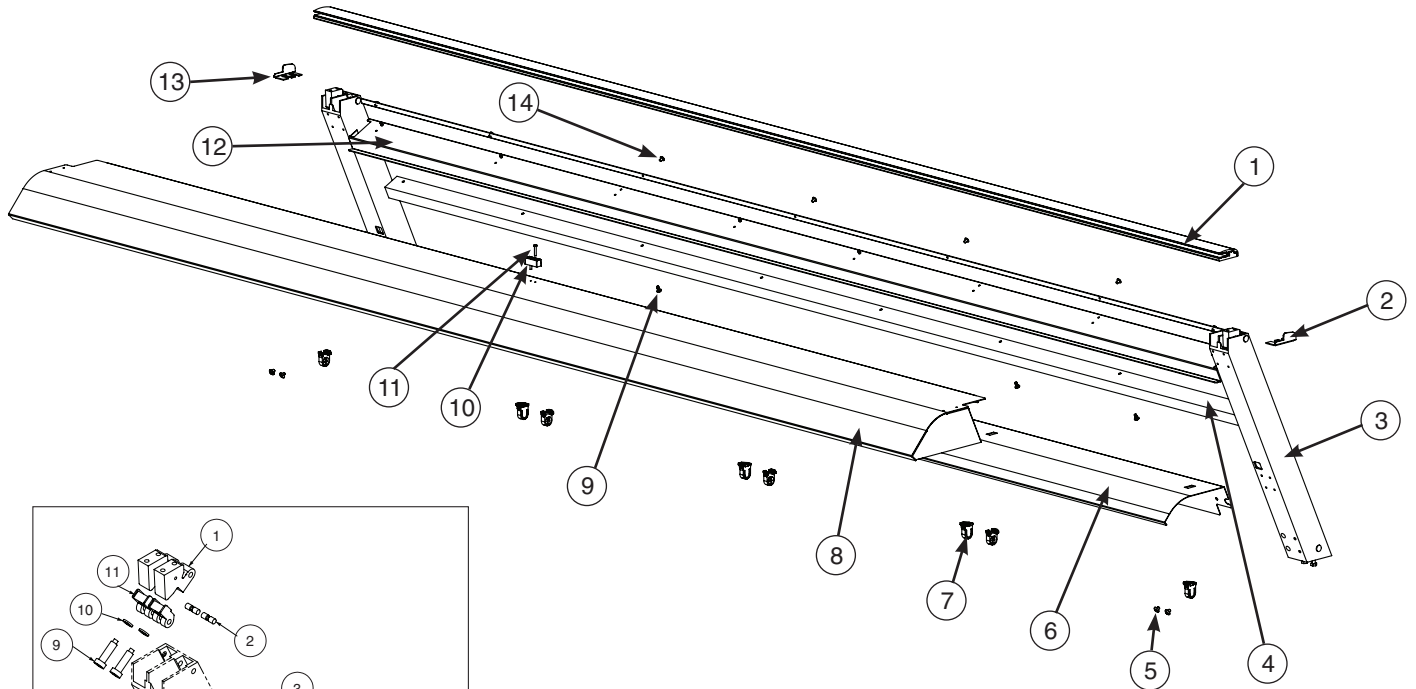

SERVICE HINGE KIT (HG-28160)

ITEM	DESCRIPTION	QTY	ITEM	DESCRIPTION	QTY
1	25° HINGE	2	7	MOUNTING BLOCKS	2
2	GAS RAM PINS	2	8	HOLE PLUG	2
3	HINGE PIN	1	9	HINGE BOLT	2
4	PIN PLUG	6	10	LOCK WASHERS	2
5	LOWER GAS RAM PIN	1	11	GAS RAM HOLDER	2
6	MOUNTING PIN	1			

ITEM	DESCRIPTION	MODEL >		ED2(SYS)-48/2S*		ED2(SYS)-72/2S*		ED2(SYS)-96/2S	
		PART NO.	QTY	PART NO.	QTY	PART NO.	QTY		
1	CLAMP ASSEMBLY	CM-26765	1	CM-26766	1	CM-26767	1		
2	CAP, END, RH	CP-27561	1	CP-27561	1	CP-27561	1		
3	SERVICE HINGE KIT (SEE INSET)	HG-28160	1	HG-28160	1	HG-28160	1		
4	TOP TRACK	TK-26752	1	TK-27858	1	TK-27860	1		
5	SCREW, 10-32 X 1/2" PHIL TRUSS	—	—	SC-2661	4	—	—		
	SCREW, 10-32 X 1/4" PAN HEAD	—	—	—	—	SC-26791	4		
6	INNER TOP	1004039	1	1004801	1	1005186	1		
7	LAMP RECEPTACLE	RP-34160	4	RP-34160	6	RP-34160	8		
8	OUTER TOP	5001738	1	5003768	1	5004234	1		
9	SCREW, 8-32 X 3/8" TRUSS HEAD	SC-22378	4	SC-22378	6	SC-22378	8		
10	DOOR STOP	—	—	DR-2533	1	DR-2533	1		
11	SCREW, 6-32 X 3/4" PAN HEAD	—	—	SC-2146	2	SC-2146	2		
12	CANOPY BACK TRACK PANEL	1002512	1	1004800	1	1005187	1		
13	CAP, END, LH	CP-27560	1	CP-27560	1	CP-27560	1		
14	SCREWS, 8-32 X 1/4" PHIL	SC-2459	12	SC-2459	7	SC-2459	9		

Part numbers and drawings are subject to change without notice.

SERVICE

SHELF ASSEMBLY (ED2(SYS)-96/2S - 5004238 - SHOWN)

*NOT SHOWN

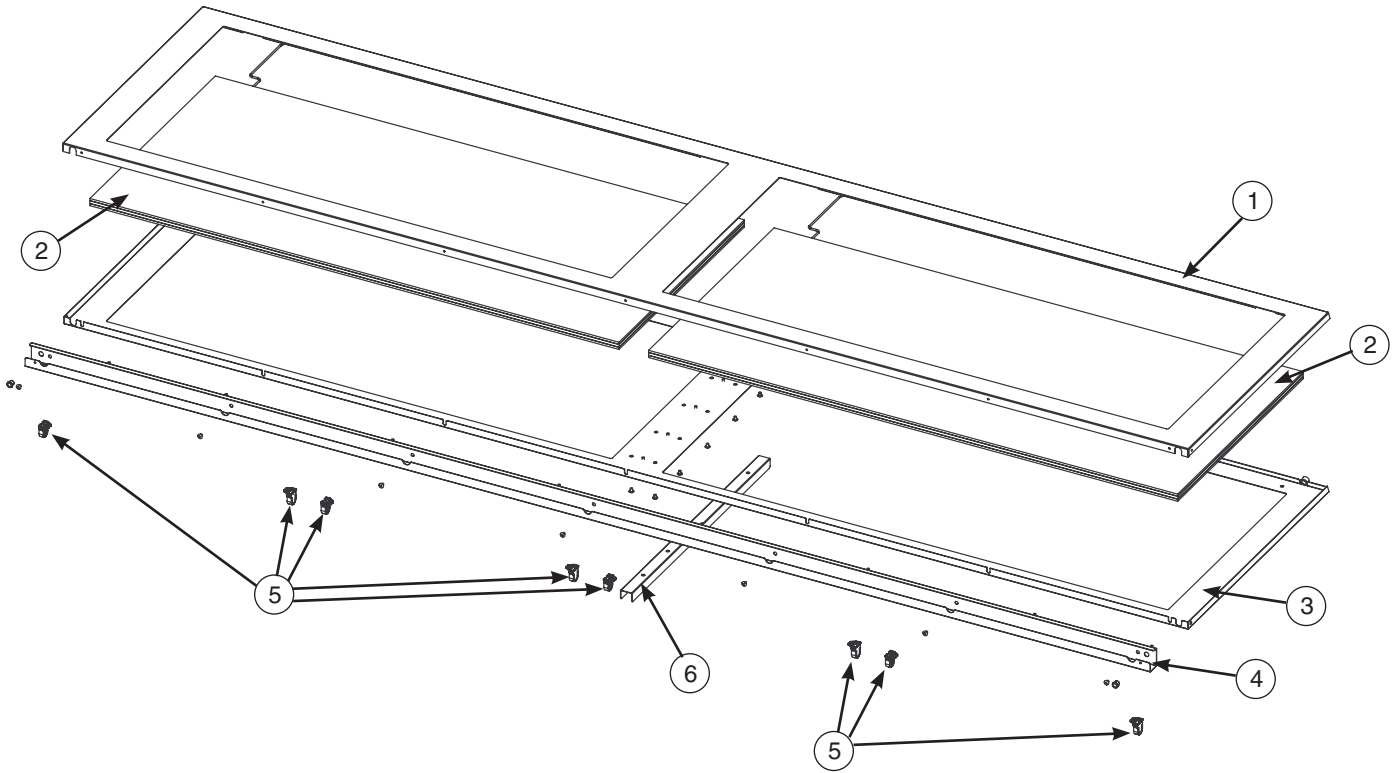

		MODEL >		ED2(SYS)-48/2S*		ED2(SYS)-72/2S*		ED2(SYS)-96/2S	
ITEM	DESCRIPTION	PART NO.	QTY	PART NO.	QTY	PART NO.	QTY	PART NO.	QTY
—	SHELF ASSEMBLY (COMPLETE)	5004203	1	5004097	1	5004238	1		
1	TOP SHELF PANEL SPOT	5004204	1	5004096	1	5004239	1		
2	HEATED GLASS SHELF, 208-240V	GL-25860	1	GL-26512	2	GL-25860	2		
3	SHELF BOTTOM PANEL	1005149	1	1005051	1	1005196	1		
4	SHELF LIGHT ATTACHMENT	1005150	1	1005052	1	1005197	1		
5	RECEPTACLE, FLORESCENT	RP-34160	4	RP-34160	6	RP-34160	8		
6	SHELF ATTACHMENT CHANNEL	—	—	1005744	1	1005744	1		

Part numbers and drawings are subject to change without notice.

ELECTRICAL ASSEMBLY (ED2(SYS)-96/2S SHOWN)

*NOT SHOWN

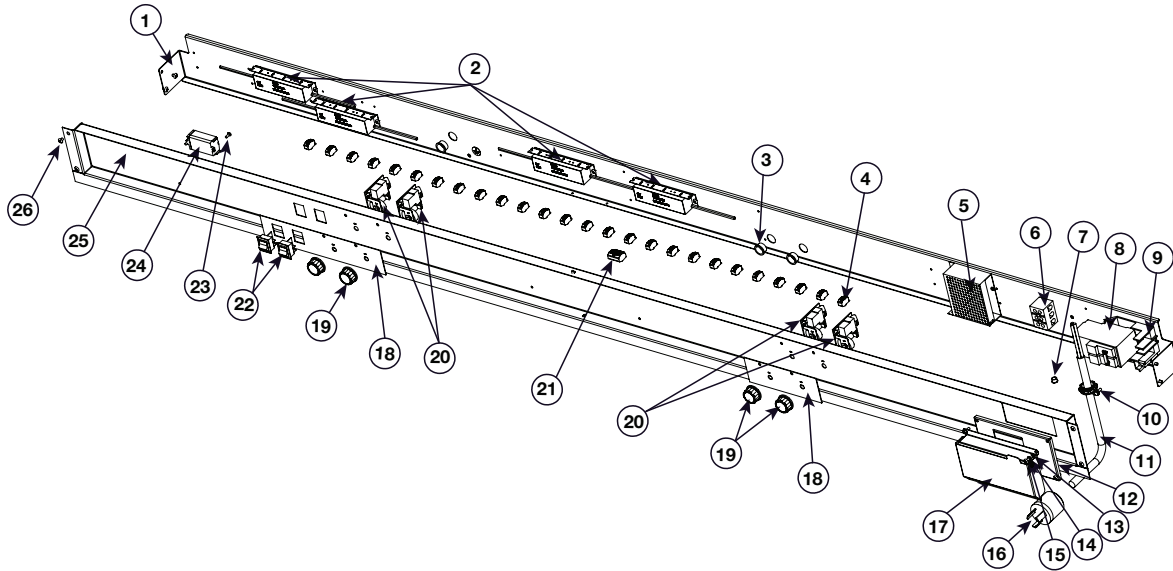

MODEL >		ED2(SYS)-48/2S*	ED2(SYS)-72/2S*	ED2(SYS)-96/2S				
ITEM	DESCRIPTION	PART NO.	QTY	PART NO.	QTY	PART NO.	QTY	
1	ELECTRONIC COMPONENT ASSEMBLY	5003229	1	5003778	1	5004242	1	
2	BALLAST, DUAL LIGHT	LP-35501	2	LP-35501	3	LP-35501	4	
3	BUSHING, 3/4" WHITE SNAP	BU-3008	3	BU-3008	3	BU-3008	3	
4	CONNECTOR-2	CR-34967	12	CR-34967	20	CR-34967	26	
5	BOARD, POWER SUPPLY, 12V DV, SWITCH	BA-36144	1	BA-36144	1	BA-36144	1	
6	T-BLOCK	BK-3019	1	BK-3019	1	BK-3019	1	
7	PLUG, 3/8" HOLE	PG-25574	1	PG-25574	1	PG-25574	1	
8	GFCI, 50AMP	208-240V	CI-34105	1	CI-34105	1	CI-34105	1
9	GFCI BASE, 50AMP	208-240V	CI-34104	1	CI-34104	1	CI-34104	1
10	CONNECTOR, 3/4" CORD	CR-3293	1	CR-3293	1	CR-3293	1	
11	CORD, 9ft (2743mm)	208-240V	CD-3607	1	CD-3304	1	CD-3304	1
		230V (Cord & Plug)	CD-3922	1	—	—	—	
12	GFCI COVER PANEL	1005125	1	1005068	1	1005068	1	
13	WASHER, #8 FLAT	WS-23424	2	WS-23424	2	WS-23424	2	
14	WASHER, #8 LOCK	WS-27045	2	WS-27045	2	WS-27045	2	
15	SCREW, 8-32 X 1/2" PHIL	SC-2425	4	SC-2425	4	SC-2425	4	
16	PLUG, NEMA 6-20P, 20A, 250V	PG-33876	1	—	—	—	—	
	PLUG, NEMA L6-30P, 30A, 250V	—	—	PG-34207	1	PG-34207	1	
17	GFCI SPLASH COVER ASSEMBLY	5015929	1	5016361	1	5016361	1	
18	PANEL OVERLAY	PE-26096	1	PE-26096	2	PE-26096	2	
19	KNOB, PLASTIC, BLACK	KN-26290	2	KN-26290	4	KN-26290	4	
20	CONTROL, 8 AMP, DIGITAL	BA-34294	2	—	—	—	—	
	CONTROL, 15 AMP, DIGITAL	—	—	BA-34295	4	BA-34295	4	
21	CONNECTOR-5	CR-34646	1	CR-34646	1	CR-34646	1	
22	SWITCH, ROCKER, HIGH-INRUSH	SW-3887	2	SW-3887	2	SW-3887	2	
23	SCREW, 6-32 X 3/8, PHIL PAN	—	—	SC-23455	2	SC-23455	2	
24	MODULAR BLOCK, 5 PIECE	—	—	BK-25567	1	BK-25567	1	
25	COVER PANEL SPOT WELD	5001739	1	5003780	1	5004233	1	
26	SCREW, 8-32 X 1/4" PHIL	SC-2459	9	SC-2459	9	SC-2459	9	
27*	CIRUIT BREAKER	230V	SW-33788	1	—	—	—	

Part numbers and drawings are subject to change without notice.

SERVICE

BASE ASSEMBLY (ED2SYS-96/2S SHOWN)

*NOT SHOWN

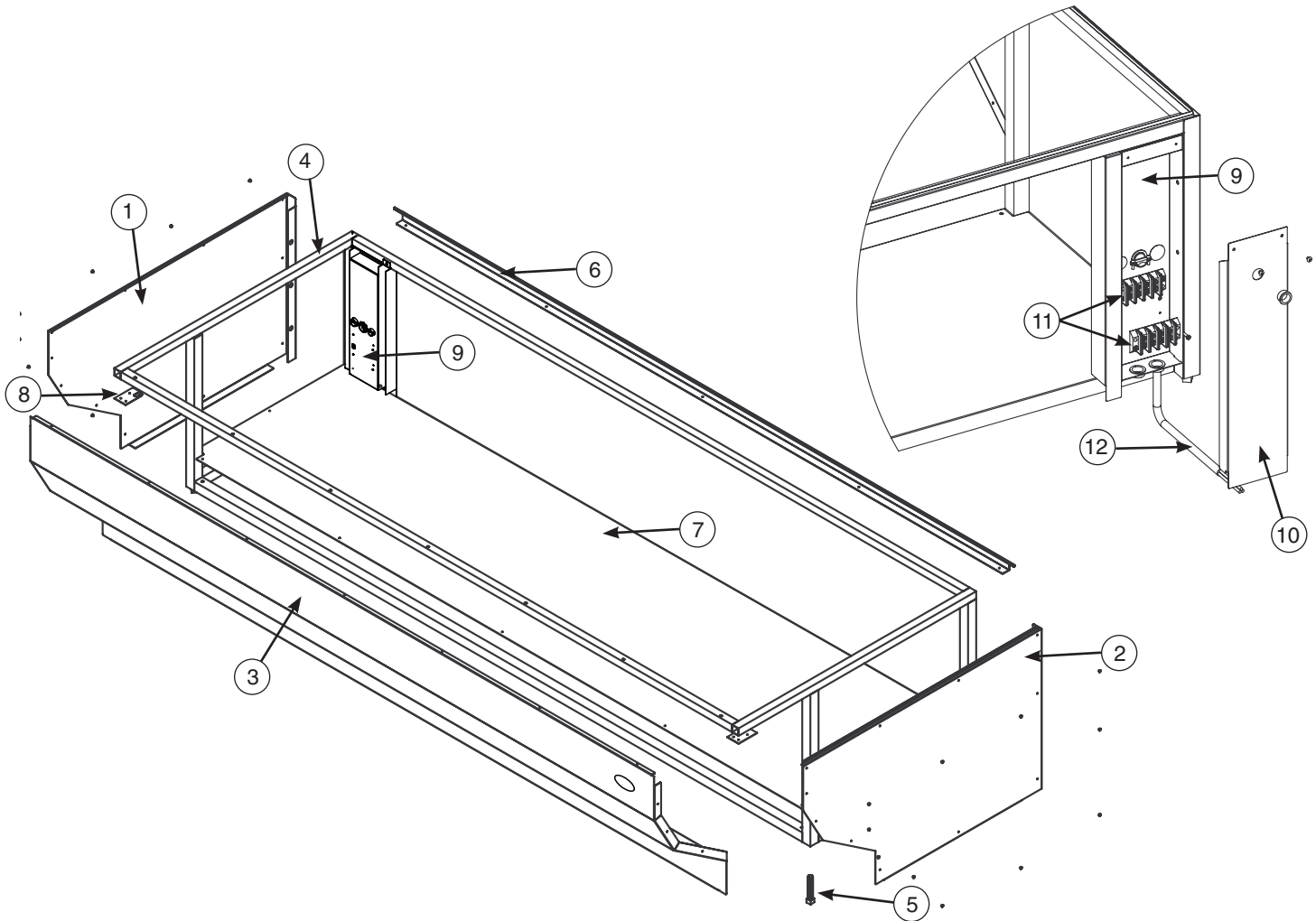

		MODEL >	ED2(SYS)-48/2S*	ED2(SYS)-72/2S*	ED2(SYS)-96/2S		
ITEM	DESCRIPTION	PART NO.	QTY	PART NO.	QTY	PART NO.	QTY
1	BASE END PANEL, LH (BLK)	1002481	1	1002481	1	1002481	1
	BASE END PANEL, LH (S/S)	1006776	1	1006776	1	1006776	1
2	BASE END PANEL, RH (BLK)	1002480	1	1002480	1	1002480	1
	BASE END PANEL, RH (S/S)	1006775	1	1006775	1	1006775	1
3	BASE FRONT PANEL (BLK)	1002478	1	1004822	1	1005157	1
	BASE FRONT PANEL (S/S)	1006774	1	1007021	1	1005158	1
4	FRAME	FR-26626	1	FR-26775	1	FR-26865	1
5	SCREW, SQUARE HEAD, 5/8 X 11	SC-2242	4	SC-2242	4	SC-2242	4
6	TRIM, BACK	1006781	1	1004823	1	1005159	1
7	BASE BOTTOM PANEL	1002479	1	1004821	1	1005158	1
8	BASE FEET HOLDER PLATES	1002482	2	1002482	2	1002482	2
9	ELECTRONIC HOUSING PANEL SPOT	5003530	1	5003530	1	5003530	1
10	BACK ACCESS PANEL COVER	1002485	1	1002485	1	1002485	1
11	TERMINAL BLOCK	BK-3023	2	BK-3023	2	BK-3023	2
12	CORD, 9ft (2743mm)	208-240V	CD-3607	1	CD-3304	1	CD-3304
		230V (Cord & Plug)	CD-3922	1	—	—	—

Part numbers and drawings are subject to change without notice.

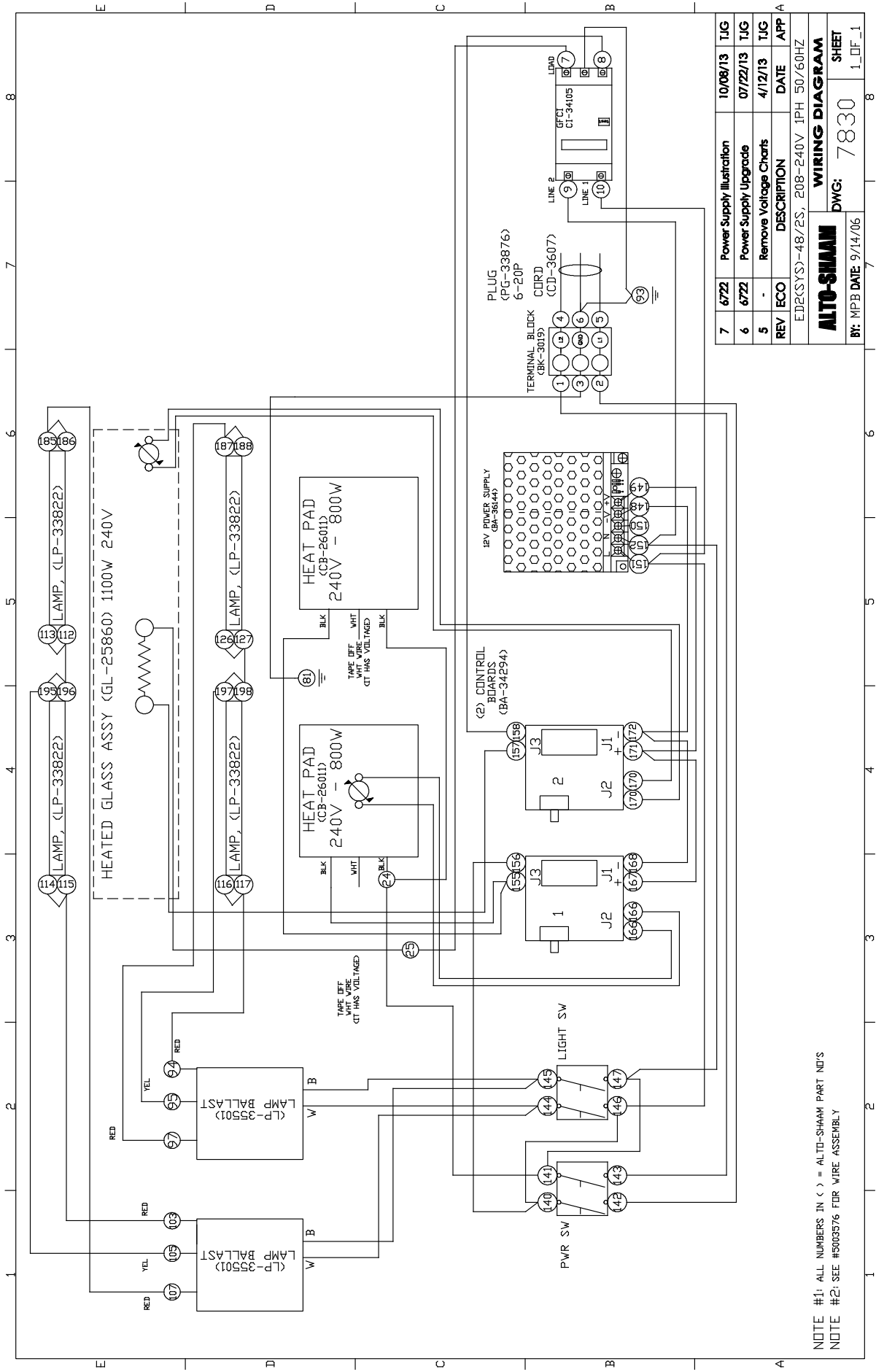

REV	ECO	DESCRIPTION	DATE	APP
7	6722	Power Supply Illustration	10/08/13	TJG
6	6722	Power Supply Upgrade	07/22/13	TJG
5	-	Remove Voltage Charts	4/12/13	TJG

ED2(SYS)-48/2S, 208-240V, 1PH, 50/60HZ
ALTO-SHAAM
WIRING DIAGRAM
DWG: 7830
BY: MPB DATE: 9/14/06

NOTE #1: ALL NUMBERS IN () = ALTO-SHAAM PART NO'S
 NOTE #2: SEE #5003576 FOR WIRE ASSEMBLY

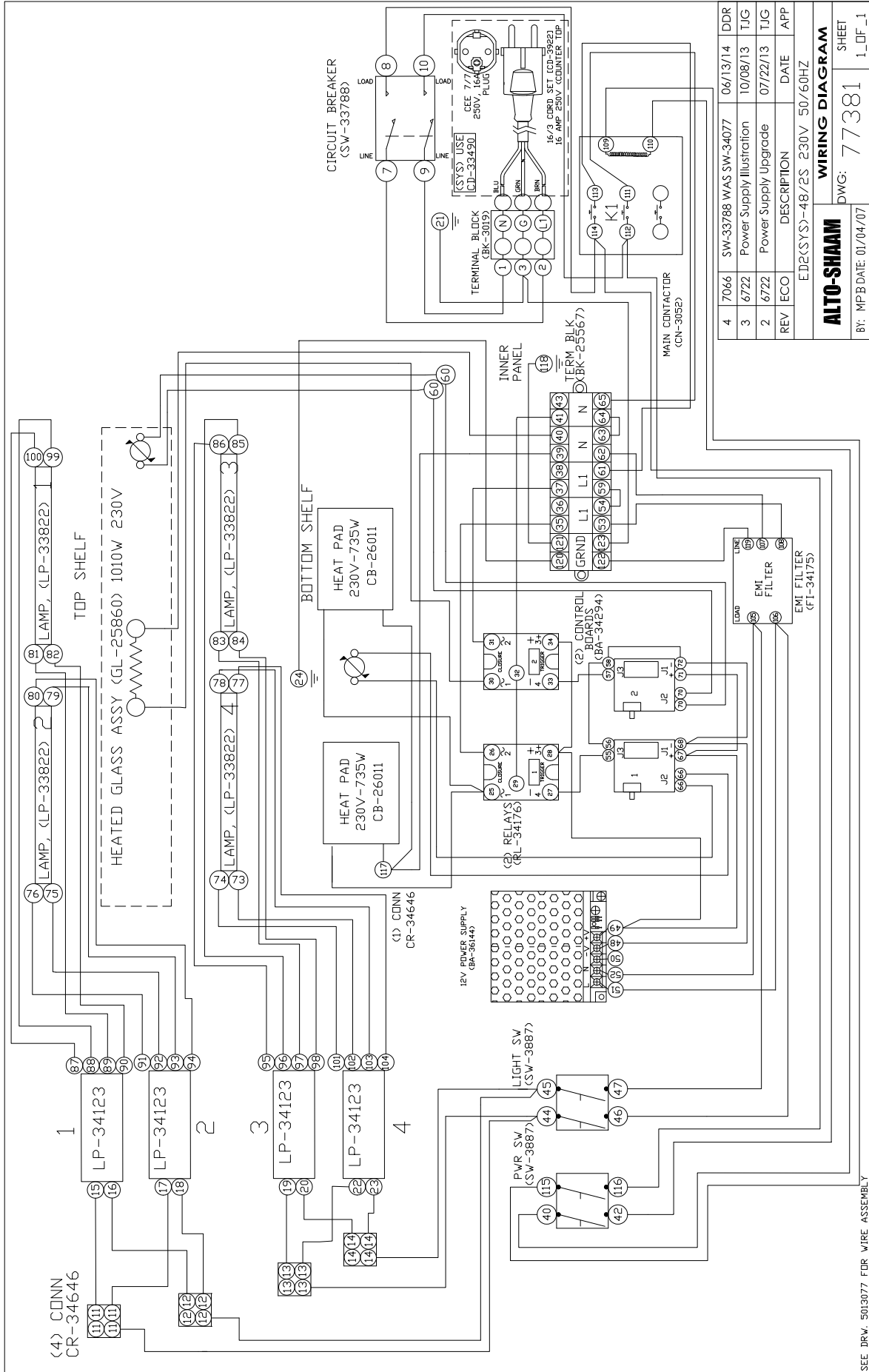

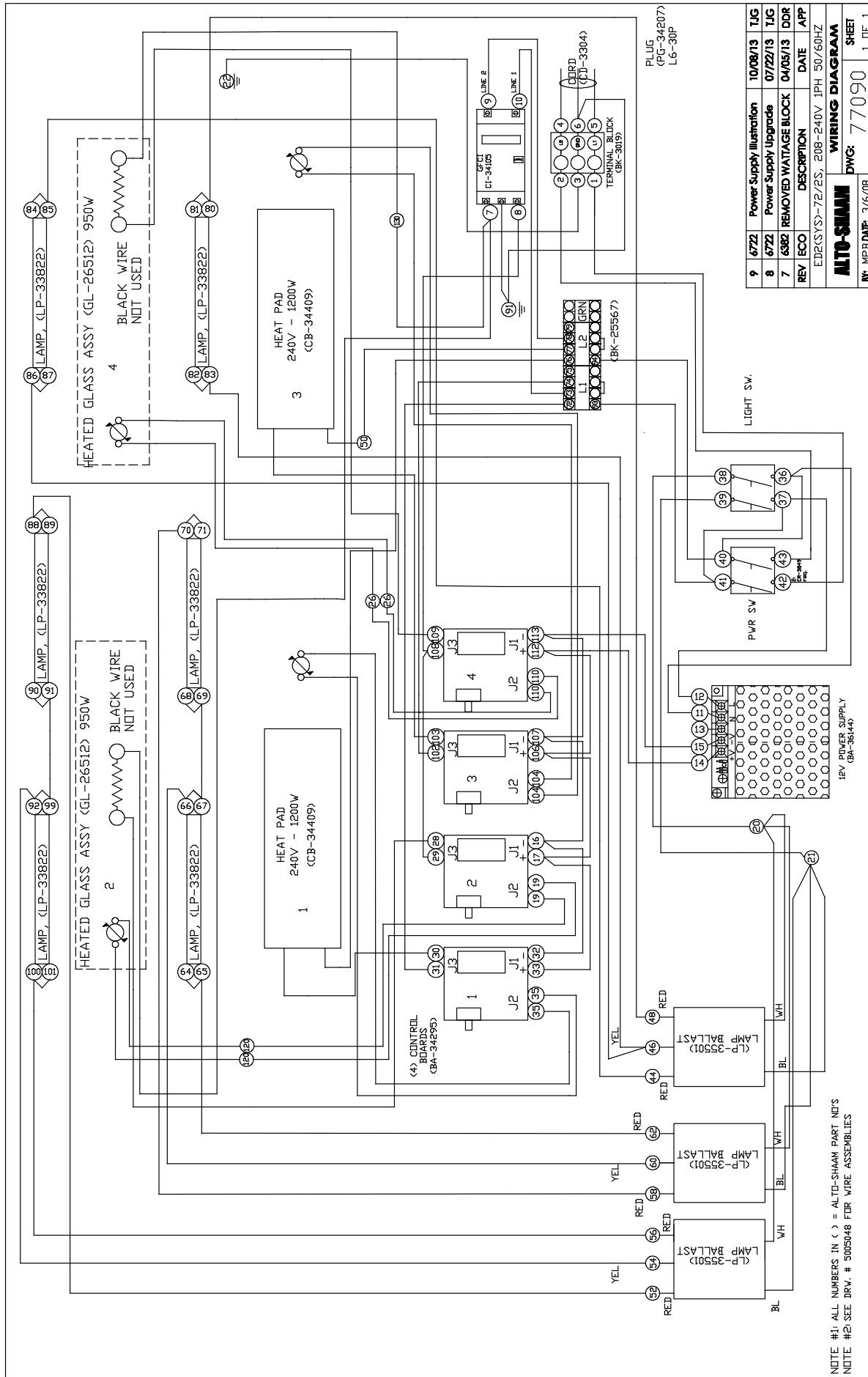

REV	ECO	DESCRIPTION	DATE	APP
9	6722	Power Supply Illustration	10/08/13	TJG
8	6722	Power Supply Upgrade	07/22/13	TJG
7	6382	REMOVED WATTAGE BLOCK	04/08/13	DDR

ED2(SYS)-72/2S, 208-240V, 1PH, 50/60HZ

WIRING DIAGRAM	
DWG:	77090
BY: MPB/DATE:	3/6/08
SHEET	1_DF_1

NOTE #1: ALL NUMBERS IN () = ALTO-SHAAM PART NO'S
 NOTE #2: SEE DRW. # 5005048 FOR WIRE ASSEMBLIES

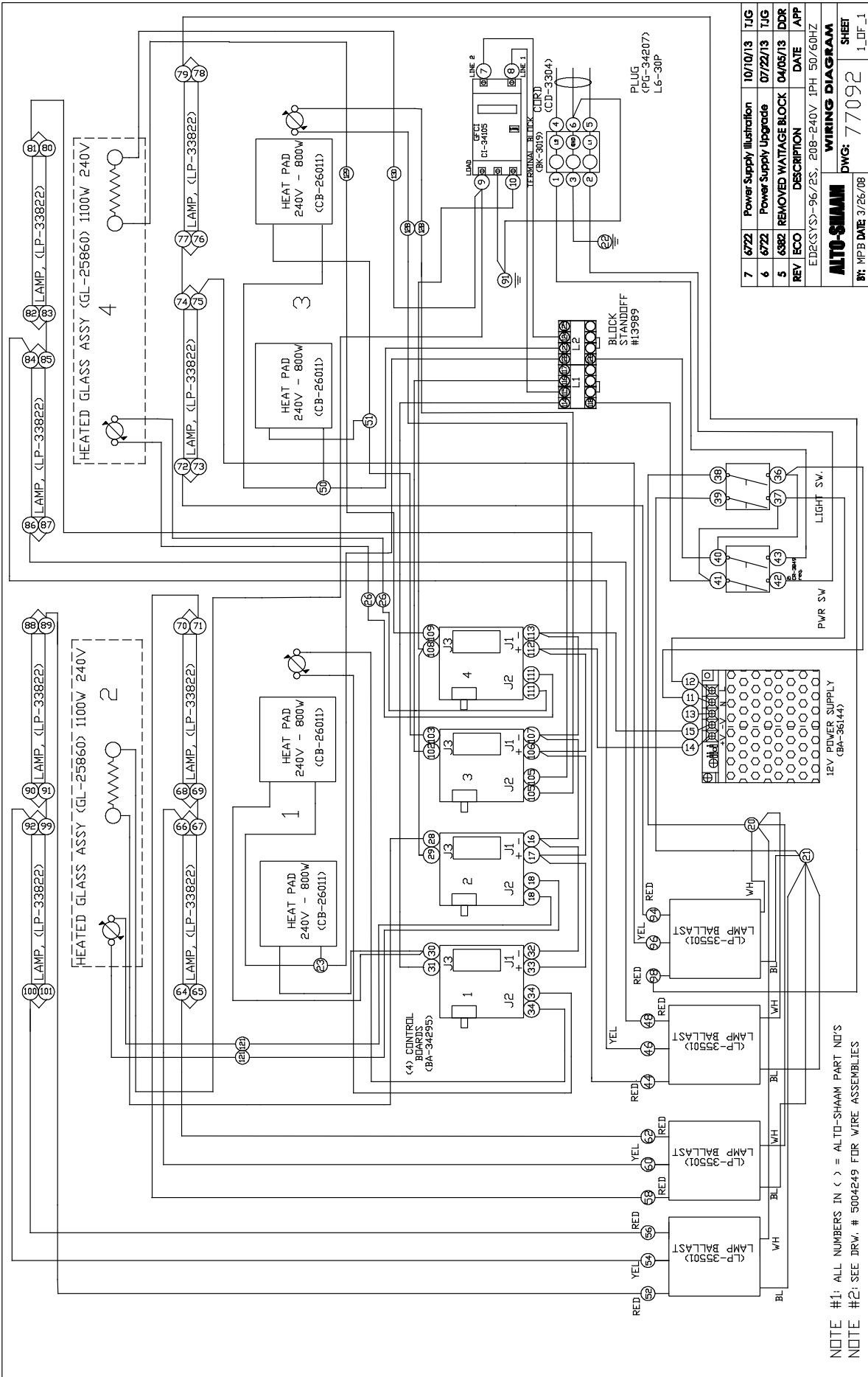

REV	ECO	DESCRIPTION	DATE	APP
7	6722	Power Supply Illustration	10/10/13	TJG
6	6722	Power Supply Upgrade	07/22/13	TJG
5	6582	REMOVED WATTAGE BLOCK	04/05/13	DDR

EDS(SYS)	96/2S	208-240V	1PH	50/60HZ
ALTO-SHAAM				
WIRING DIAGRAM				SHEET
DWG: 77092				1_DF_1
BT: MPB DATE: 3/26/08				

NOTE #1: ALL NUMBERS IN () = ALTO-SHAAM PART NO'S
 NOTE #2: SEE DRW. # 5004249 FOR WIRE ASSEMBLIES

TRANSPORTATION DAMAGE and CLAIMS



All Alto-Shaam equipment is sold F.O.B. shipping point, and when accepted by the carrier, such shipments become the property of the consignee.

Should damage occur in shipment, do not put the appliance into service until the damage has been inspected by an authorized Alto-Shaam service provider.

Shipping damages are a matter between the carrier and the consignee. In such cases, the carrier is assumed to be responsible for the safe delivery of the merchandise, unless negligence can be established on the part of the shipper.

1. Make an immediate inspection while the equipment is still in the truck or immediately after it is moved to the receiving area. Do not wait until after the material is moved to a storage area.
2. Do not sign a delivery receipt or a freight bill until you have made a proper count and inspection of all merchandise received.
3. Note all damage to packages directly on the carrier's delivery receipt.
4. Make certain the driver signs this receipt. If he refuses to sign, make a notation of this refusal on the receipt.
5. If the driver refuses to allow inspection, write the following on the delivery receipt:
Driver refuses to allow inspection of containers for visible damage.
6. Telephone the carrier's office immediately upon finding damage, and request an inspection. Mail a written confirmation of the time, date, and the person called.
7. Save any packages and packing material for further inspection by the carrier.
8. Promptly file a written claim with the carrier and attach copies of all supporting paperwork.

We will continue our policy of assisting our customers in collecting claims which have been properly filed and actively pursued. We cannot, however, file any damage claims for you, assume the responsibility of any claims, or accept deductions in payment for such claims.

LIMITED WARRANTY

Alto-Shaam, Inc. warrants to the original purchaser only that any original part that is found to be defective in material or workmanship will, at Alto-Shaam's option, subject to provisions hereinafter stated, be replaced with a new or rebuilt part.

The original parts warranty period is as follows:

For the refrigeration compressor on Alto-Shaam Quickchillers™, five (5) years from the date of installation of appliance.

For the heating element on Halo Heat® cooking and holding ovens, as long as the original purchaser owns the oven. This excludes holding only equipment.

For all other original parts, one (1) year from the date of installation of appliance or fifteen (15) months from the shipping date, whichever occurs first.

The labor warranty period is one (1) year from the date of installation or fifteen (15) months from the shipping date, whichever occurs first.

Alto-Shaam will bear normal labor charges performed during standard business hours, excluding overtime, holiday rates or any additional fees.

To be valid, a warranty claim must be asserted during the applicable warranty period. This warranty is not transferable.

THIS WARRANTY DOES NOT APPLY TO:

1. Calibration.
2. Replacement of light bulbs, door gaskets, and/or the replacement of glass due to damage of any kind.
3. Equipment damage caused by accident, shipping, improper installation or alteration.
4. Equipment used under conditions of abuse, misuse, carelessness or abnormal conditions, including but not limited to, equipment subjected to harsh or inappropriate chemicals, including but not limited to, compounds containing chloride or quaternary salts, poor water quality, or equipment with missing or altered serial numbers.
5. Damage incurred as a direct result of poor water quality, inadequate maintenance of steam generators and/or surfaces affected by water quality. Water quality and required maintenance of steam generating equipment is the responsibility of the owner/operator.
6. Damage caused by use of any cleaning agent other than Alto-Shaam's Combitherm® Cleaner, including but not limited to damage due to chlorine or other harmful chemicals. **Use of Alto-Shaam's Combitherm® Cleaner on Combitherm® ovens is highly recommended.**
7. Any losses or damage resulting from malfunction, including loss of product, food product, revenue, or consequential or incidental damages of any kind.
8. Equipment modified in any manner from original model, substitution of parts other than factory authorized parts, removal of any parts including legs, or addition of any parts.

This warranty is exclusive and is in lieu of all other warranties, express or implied, including the implied warranties of merchantability and fitness for a particular purpose. In no event shall Alto-Shaam be liable for loss of use, loss of revenue or profit, or loss of product, or for any indirect, special, incidental, or consequential damages. No person except an officer of Alto-Shaam, Inc. is authorized to modify this warranty or to incur on behalf of Alto-Shaam any other obligation or liability in connection with Alto-Shaam equipment.



Effective November 1, 2012

W164 N9221 Water Street • P.O. Box 450
Menomonee Falls, Wisconsin 53052-0450 U.S.A.

PHONE: 262.251.3800 • 800.558.8744 U.S.A. / CANADA

FAX: 262.251.7067 • 800.329.8744 U.S.A. ONLY

www.alto-shaam.com

PRINTED IN U.S.A.