



BEVERAGE-AIR

Project: _____	AIA#
Item: _____	
Location: _____	SIS#
Approved: _____	

DP FOOD PREPARATION SERIES

MODELS:
DP60HC-ALT

DP60HC Deli/Pizza Two Doors Prep Table Left Side Compressor Hydrocarbon Series

3 Year Parts/Labor Warranty
Additional 2 Year Compressor Warranty

CABINET CONSTRUCTION



DP60HC-ALT

- Stainless steel front, sides, top, doors, and grille (*galvanized back & bottom*)
- Interior liner is made of corrosion resistant aluminum
- Aluminum top interior liner prevents spill from falling into cabinet
- Stainless steel top
- Removable hoods and insulated lid assemblies are made of matching stainless steel
- Doors are self-closing on cam-lift hinges
- Snap-in door gaskets
- 120° Stay-open door feature
- Easy lift-off door removal for service and cleaning
- Field reversible doors
- 3" Casters, 2 with brakes standard
- 19" Wide reversible cutting board constructed of white polyethylene plastic
- Cutting board removable for cleaning
- Two epoxy-coated steel wire shelves per door
- Units will accept pans up to 6" deep (pans are not included)
- Raised rail maintains temperatures between 36° - 38°F

OPTIONS & ACCESSORIES

- Stainless steel back and grille
- Stainless steel interior
- Combination models available
- Locks
- Composite cutting board
- Bun tray rack
- 6" Casters
- 6" Legs Black or Seismic / Flanged
- Remote option

REFRIGERATION SYSTEM

- Refrigeration system uses R290 refrigerant to comply with all environmental concerns
- Automatic, electric defrost
- Epoxy coated evaporator coil

DP60HC Food Preparation : Deli/Pizza Prep Series



3779 Champion Blvd., Winston-Salem, NC 27105
1-888-845-9800 Fax: 1-336-245-6453
Beverage-Air.com sales@bevair.com



BEVERAGE-AIR

MODEL	DP60HC-ALT
EXTERNAL DIMENSIONAL DATA	
Width Overall	60"
Depth Overall with Cutting Board	37"
Height Overall with 3" Casters	53 1/4"
Number of Doors	2
Depth with Door Open 90 °	52 1/4"
Door Opening (in)	(2) 18 5/8" x 23 5/8"
Depth, Cutting Board	19"
INTERNAL DIMENSIONAL DATA	
NET Capacity (cubic ft.)	17.8
Internal Width Useable (in)	41"
Internal Depth Overall (in)	26"
Internal Height Overall (in)	23 7/8"
Number of Shelves	4
ELECTRICAL DATA	
Full Load Amperes 115/60/1	4.5
REFRIGERATION DATA	
Horsepower	1/2
Capacity (BTU/Hr)*	2940
WEIGHT DATA	
Gross Weight (Crated lbs)	440 lbs
Height - Crated	48"
Width - Crated	69 1/4"
Depth - Crated	36"

Deli/Pizza Preparation Table

Models: DP60HC-ALT

Model Views

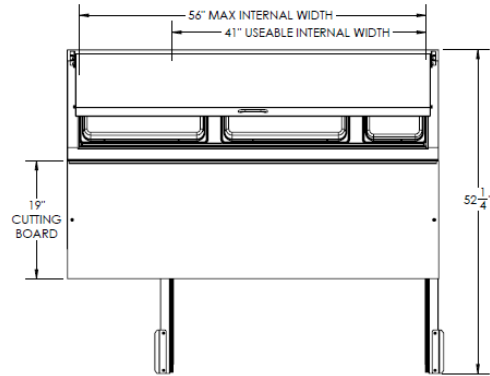

Plan View

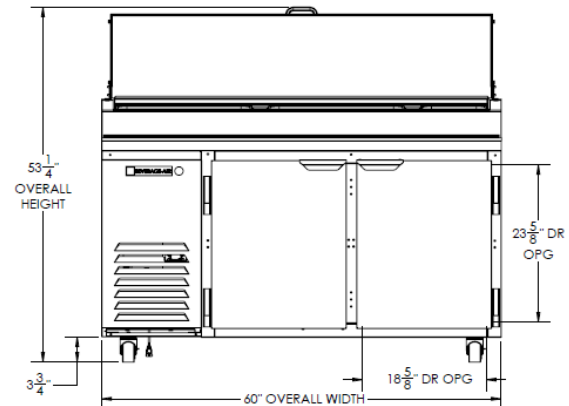

Elevation View

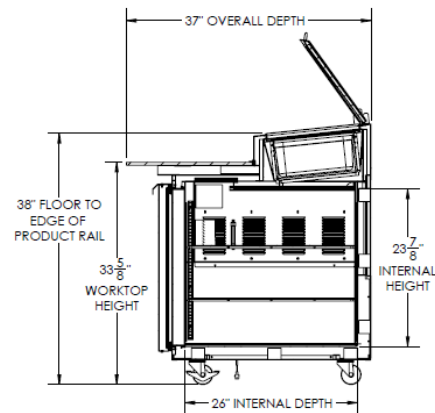

Side View

ELECTRICAL CONNECTION



115/60/1
NEMA-5-15P

Units pre-wired at factory and include 8' long cord and plug set.



an Ali Group Company



The Spirit of Excellence

3779 Champion Blvd., Winston-Salem, NC 27105
1-888-845-9800 Fax: 1-336-245-6453
Beverage-Air.com sales@bevair.com