



**IMPORTANT FOR FUTURE REFERENCE**  
Please complete this information and retain this manual for the life of the equipment:

Model #: \_\_\_\_\_  
Serial #: \_\_\_\_\_  
Date Purchased: \_\_\_\_\_

# INSTALLATION & OPERATION MANUAL

## Electric Cabinet Base Convection Steamer ECX-16 ECX-24

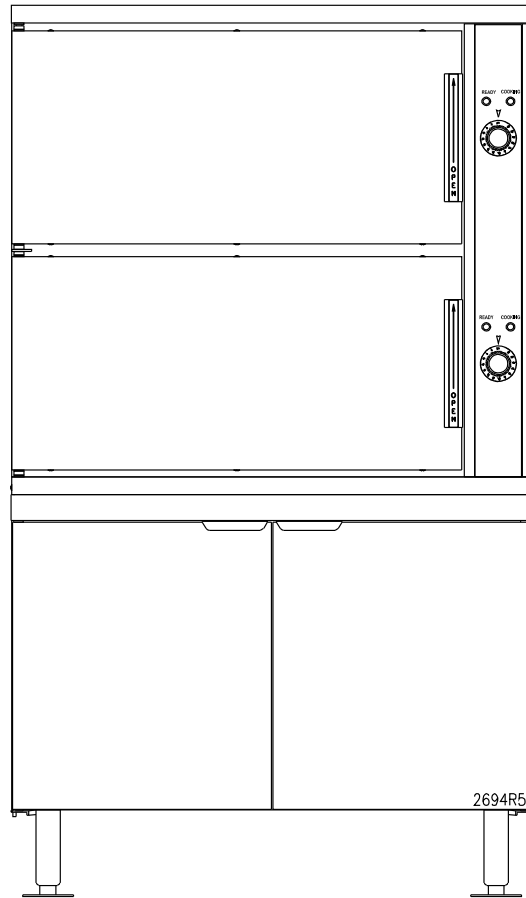

### **WARNING**

Improper installation, adjustment, alteration, service or maintenance can cause property damage, injury or death. Read the installation, operating and maintenance instructions thoroughly before installing or servicing this equipment.

### **CROWN FOOD SERVICE EQUIPMENT**

 A Middleby Company

70 Oakdale Road, Downsview (Toronto) Ontario, Canada, M3N 1V9  
Telephone: 919-762-1000      [www.crownsteamgroup.com](http://www.crownsteamgroup.com)

Printed in Canada



**IMPORTANT NOTES FOR INSTALLATION AND OPERATION**



**This is the safety alert symbol. It is used to alert you to potential personal injury hazards. Obey all safety messages that follow this symbol to avoid possible injury or death.**



**WARNING: Improper installation, operation, adjustment, alteration, service or maintenance can cause property damage, injury or death. Read the installation, operating and maintenance instructions thoroughly before installing, operating or servicing this equipment.**



**CAUTION: Operating, testing, and servicing should only be performed by qualified personnel.**



**NOTICE: Contact the factory, the factory representative or local service to perform maintenance and repairs.**

**Do not attempt to operate this unit in the event of power failure.**

**Intended for commercial use only. Not for household use.**

**This manual should be retained for future reference.**

INSTALLATION AND OPERATION MANUAL,  
ELECTRIC CABINET BASE CONVECTION STEAMER, ECX-16, ECX-24

**TABLE OF CONTENTS**

<b>DESCRIPTION</b>	<b>PAGE</b>
Important Notes for Installation and Operation . . . . .	2
1.0 Service Connections . . . . .	4
2.0 Introduction . . . . .	6
3.0 Installation Instructions . . . . .	7
4.0 Operating Instructions . . . . .	10
5.0 Boilers with CSD-1 Controls . . . . .	13
6.0 Periodic Maintenance . . . . .	15
7.0 Cleaning Instructions . . . . .	18
8.0 Adjustments . . . . .	19
9.0 Troubleshooting . . . . .	21

# INSTALLATION AND OPERATION MANUAL, ELECTRIC CABINET BASE CONVECTION STEAMER, ECX-16, ECX-24

## 1.0 SERVICE CONNECTIONS

### SERVICE CONNECTIONS

- ⚡ - ELECTRICAL CONNECTION: 1/2" conduit connection to controls. 120VAC-60-1PH  
2 AMPS per compartment or to be as specified on data plate.
- 💧 - BOILER FEED WATER: 1/2" NPT, 25-50 PSI(170-345 kPa)
- 💧 - CONDENSATE COLD WATER: 1/2" NPT, 25-50 PSI(170-345 kPa)
- 💧 - DRAIN: 2" IPS piped to open floor drain. No Solid Connection.
- ⚡ - STEAM TAKE-OFF CONNECTION: 3/4" IPS optional to operate adjacent equipment.

### ELECTRICAL CHARACTERISTICS

MODEL	AMPS PER LINE								
	kW	PHASE	208V	220V	240V	380V	415V	480V	600V
ECX-16	42	3	116.6	110.2	101	63.8	58.4	50.5	40.4
	48	3	N/A	N/A	115.5	72.9	66.8	57.8	46.2

### WATER QUALITY STATEMENT

Water is the essential ingredient in steam equipment, water quality is the major factor affecting the performance of your appliance, Crown Steam Group offers a Comprehensive Water Treatment System which exceeds our minimum water requirements. Proof of installation and proper cartridges replacement is required for warranty coverage. Water supply to Crown Steam Group steamers must be within these guidelines:

Total dissolved solids	Less than 60 PPM
Total alkalinity	Less than 20 PPM
Silica	Less than 13 PPM
Chlorine	Less than 1.5 PPM
pH Factor	6.8-7.3

Water which does not meet these standards should be treated with the installation of Crown Steam Group's Water Treatment System. Call 919-762-1000 if you have questions concerning your water meeting these parameters. \*Failure or malfunction of this appliance due to poor water quality is not covered under warranty. Reference [www.crownsteamgroup.com](http://www.crownsteamgroup.com) for complete warranty details and instructions.

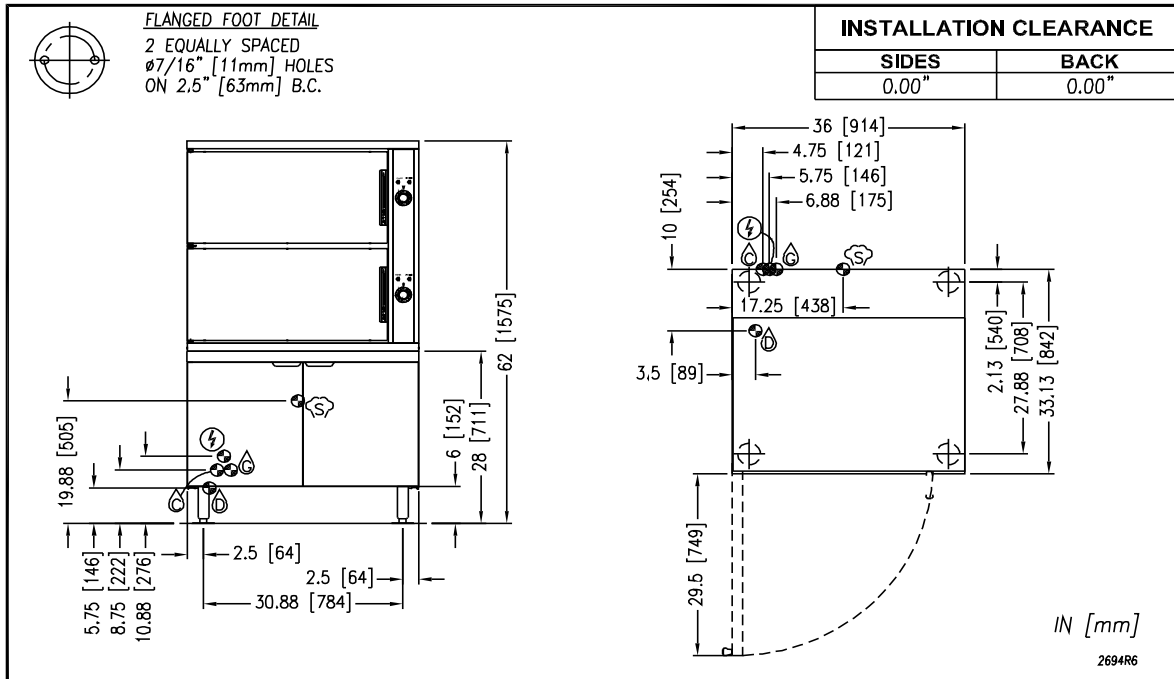

*As continued product improvement is a policy of Crown, specifications are subject to change without notice.*

# INSTALLATION AND OPERATION MANUAL, ELECTRIC CABINET BASE CONVECTION STEAMER, ECX-16, ECX-24

## 1.0 SERVICE CONNECTIONS

### SERVICE CONNECTIONS

- ⚡ - ELECTRICAL CONNECTION: Rating to be as specified on data plate.
- 💧 - BOILER FEED WATER: 1/2" NPT, 25–50 PSI(170–345 kPa)
- 💧 - CONDENSATE COLD WATER: 1/2" NPT, 25–50 PSI(170–345 kPa)
- 💧 - DRAIN: 2" IPS piped to open floor drain, No Solid Connection.
- ⚙️ - STEAM TAKE-OFF CONNECTION: 3/4" IPS optional to operate adjacent equipment.

### ELECTRICAL CHARACTERISTICS

MODEL	AMPS PER LINE								
	kW	PHASE	208V	220V	240V	380V	415V	480V	600V
ECX-24	42	3	116.6	110.2	101	63.8	58.4	50.5	40.4
	48	3	N/A	N/A	115.5	72.9	66.8	57.8	46.2

### WATER QUALITY STATEMENT

Water is the essential ingredient in steam equipment. Water quality is the major factor affecting the performance of your appliance. Crown Steam Group offers a Comprehensive Water Treatment System which exceeds our minimum water requirements. Proof of installation and proper cartridges replacement is required for warranty coverage.

Water supply to Crown Steam Group steamers must be within these guidelines:

Total dissolved solids	Less than 60 PPM
Total alkalinity	Less than 20 PPM
Silica	Less than 13 PPM
Chlorine	Less than 1.5 PPM
pH Factor	6.8–7.3

Water which does not meet these standards should be treated with the installation of Crown Steam Group's Water Treatment System. Call 919-762-1000 if you have questions concerning your water meeting these parameters.

\*Failure or malfunction of this appliance due to poor water quality is not covered under warranty.

Reference [www.crownsteamgroup.com](http://www.crownsteamgroup.com) for complete warranty details and instructions.

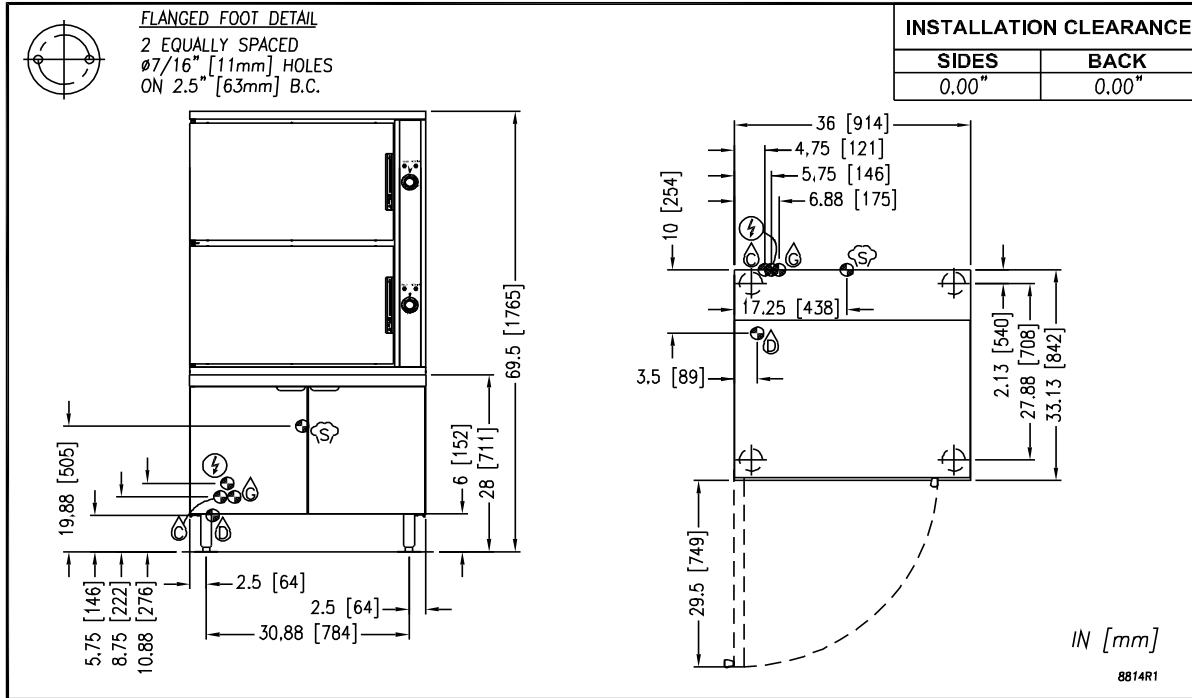

*As continued product improvement is a policy of Crown, specifications are subject to change without notice.*

INSTALLATION AND OPERATION MANUAL,  
ELECTRIC CABINET BASE CONVECTION STEAMER, ECX-16, ECX-24

## **2.0 INTRODUCTION**

### **DESCRIPTION**

Models ECX-16 and ECX-24 are convection steamers mounted on cabinet base and an electric steam boiler. ECX-16 steamer has a pan capacity of 16 (2½") pans. ECX-24 steamer has a pan capacity of 24 (2½") pans.

### **BASIC FUNCTION:**

The sequence of operation is as follows:

1. Turn on the main power switch. A green pilot light will indicate main power is on and steam generating will begin. In approximately 20 minutes, sufficient amount of pressurized steam will have been generated in the heat exchanger and the READY pilot light will come on. OFF shuts off the power supply to the boiler and opens the automatic blowdown valve, if so equipped, emptying the boiler and releasing water and steam to the drain. The manual blowdown valve will have to be opened to drain if not equipped with automatic blowdown valve.
2. Boiler pressure gauge should read 9 - 11 psi during operation, 0 psi during shutdown.
3. The compartment cooker is ready for use when the READY light is on. Place pans of food to be cooked into compartment(s) and close door(s).
4. Set timer(s) to cook time desired. Cooking will commence and cooking time may be interrupted at any time by opening door(s) and resumed again by closing door(s).
5. The buzzer will sound indicating the end of the cooking cycle and that steam has stopped entering the compartment(s). The COOKING pilot will go off and the READY light will come on. Turn the timer(s) to the OFF position to stop the buzzer.

INSTALLATION AND OPERATION MANUAL,  
ELECTRIC CABINET BASE CONVECTION STEAMER, ECX-16, ECX-24

### **3.0 INSTALLATION INSTRUCTIONS**

#### **GENERAL**

The electric boiler is designed to ASME Code and approved as a steam heating boiler restricted to operation at pressure not to exceed 15 psi. Boilers are electrically rated as shown on page 4. Boiler may have optional CSD-1 controls.

#### **INSTALLATION**

##### **UNPACKING**

Immediately after unpacking, check for possible shipping damage. If the appliance is found to be damaged, save the packaging material and contact the carrier within 15 days of delivery. Before installing, verify the electrical rating agrees with the specification on the rating plate.

##### **LOCATION**

Position the appliance in its installation location. Check that there are sufficient clearances to service the controls, door swing, etc. Also adequate clearance must be left for making the required supply and drain connections.

Allow enough space between any other piece of equipment or wall for service access. Service to the controls may be required on the left and/or right side panels of the cabinet.

##### **INSTALLATION CODES AND STANDARDS**

The appliance must be installed in accordance with:

###### **In Canada:**

Provincial and local codes, or in the absence of local codes, with the Canadian Electric Code, CSA C22.1 (latest edition). Copies may be obtained from the Canadian Standards Association, 178 Rexdale Blvd., Etobicoke, Ontario, Canada, M9W 1R3.

###### **In the U.S.A.:**

State and local codes, or in the absence of local codes, with the National Electrical Code, ANSI/NFPA-70 (latest edition). Copies may be obtained from The National Fire Protection Association, Batterymarch Park, Quincy, MA, USA, 02269.

INSTALLATION AND OPERATION MANUAL,  
ELECTRIC CABINET BASE CONVECTION STEAMER, ECX-16, ECX-24

**3.0 INSTALLATION INSTRUCTIONS** (Continued)

**LEVELING AND ANCHORING THE CABINET**

1. Place appliance in the installation position.
2. Place a carpenter's level on top of the appliance and turn the adjustable feet to level side-to-side and front-to-back.
3. Mark hole locations on the floor through the anchoring holes provided in the flanged adjustable feet.
4. Remove appliance from installation position and drill holes in locations marked on the floor. (See installation diagram on page 4.) Insert proper anchoring devices (not supplied).
5. Place appliance back in the installation position.
6. Place carpenter's level on top appliance and re-level side-to-side and front-to-back.
7. Bolt and anchor appliance securely to the floor.
8. Seal bolts and flanged feet with silastic or equivalent compound.

**ELECTRICAL CONNECTIONS**

	<b>WARNING: Electrical and grounding connections must comply with the applicable portions of the National Electrical Code and/or other local electrical codes.</b>
---	--

	<b>WARNING: Disconnect electrical power supply and place a tag at the disconnect switch to indicate you are working on the circuit.</b>
---	---

When making electrical connections, use copper wire suitable for at least 200°F (90°C). The steamer must be grounded in accordance with the National Electrical Code or applicable local codes. The wiring diagram is located on the inside of the right panel.

**EXHAUST HOOD**

An exhaust system should be located directly above the boiler to exhaust steam and heat generated by the appliance.



INSTALLATION AND OPERATION MANUAL,  
ELECTRIC CABINET BASE CONVECTION STEAMER, ECX-16, ECX-24

**3.0 INSTALLATION INSTRUCTIONS** (Continued)

**PLUMBING CONNECTIONS** (See Page 4 and 5)

	<b>WARNING: Plumbing connections must comply with applicable sanitary, safety, and plumbing codes.</b>
---	--

**Water Supply Connection**

The incoming cold water supply connection, at the rear of the boiler cabinet, requires 3/8" tubing and water pressure of 25 - 50 psig. A manual shut-off valve must be provided convenient to the appliance. This valve should be open when the boiler is in operation.

	<b>WARNING: If your equipment was supplied with split water lines and a water treatment system, connect the system to the connection marked "FILTERED WATER IN" only (Use cold water). Make a second connection to the "CONDENSER WATER IN" from a cold and unfiltered water supply.</b>
--	--

**FAILURE OR MALFUNCTION OF THIS APPLIANCE DUE TO POOR WATER QUALITY IS NOT COVERED UNDER WARRANTY. SEE WATER QUALITY STATEMENT (PAGE 4, 5).**

**Drain Connection**

The boiler drain (2" IPS) should be piped to a floor drain near the steamer (NOT directly under the steamer). There should be no solid drain connection; an "open gap" between the boiler and the floor drain is required.

INSTALLATION AND OPERATION MANUAL,  
ELECTRIC CABINET BASE CONVECTION STEAMER, ECX-16, ECX-24

#### **4.0 OPERATING INSTRUCTIONS**

For CSD-1 equipped boilers, see section 5.0.

##### **BOILER CONTROLS** (Inside Cabinet)

- |                         |   |
|-------------------------|---|
| Main Power Switch       | - ON fills the boiler tank and turns the boiler heaters on. You should allow 20 minutes to fill the tank and generate steam.  |
|                         | - OFF shuts off the boiler heaters and opens the Automatic Blowdown Valve, emptying the boiler tank and releasing water and steam to the drain. This should be done daily to remove sediment, lime, or scale. |
| Pilot Light             | - Indicates main power is ON.   |
| Boiler Pressure Gauge   | - Should read 9 - 11 psig during operation; 0 psig during shutdown.   |
| Water Level Sight Glass | - Observe level of water and water quality in the boiler. Murkiness in the water indicates inadequate water quality; the owner must supply proper water to the boiler (see page 4).                           |
| Water Level Control     | - While boiler is ON, briefly open the water level control valve once a day to remove any sediment that might accumulate. (See page 12 for detailed instructions.)  |
| Safety Valve            | - This valve will release (pop off) if the boiler has too much pressure. Once a week, this valve should be tripped during operation to make sure it functions properly.                                       |

##### **OPERATION OF THE BOILER**

Turn on water and power supply to appliance.

Open cabinet door and turn main power switch ON. Pilot light ignites and water begins to fill boiler - observe water gauge sight glass to verify that proper water level is reached.

Once the proper water level is reached, the heaters begin to heat the water. Heaters require about 15 minutes to begin steam generation. The boiler pressure gauge in the cabinet should indicate steam pressure in a range of 9 to 11 psig.

##### **SHUT DOWN**

Turn the Main Power Switch OFF. Open manual drain valve. If unit is supplied with Automatic Blowdown Valve, it will open, draining the boiler and releasing hot water and steam to the drain.

INSTALLATION AND OPERATION MANUAL,  
ELECTRIC CABINET BASE CONVECTION STEAMER, ECX-16, ECX-24

**4.0 OPERATING INSTRUCTIONS** (Continued)

**COOKER SECTION**



**CAUTION: Live steam and accumulated hot water in the compartment may be released when the door is opened.**

Start-up procedures for your steamer must be completed once daily prior to operation. (See instruction plate or above for boiler start up procedures).

If appliance is equipped with optional - "Load Compensating Timer" a pre-heat thermostat is installed in each compartment. This allows the compartment to pre-heat to 185°F before the cooking time starts. Set timer for one minute. Ready light will go out and cook light will come on; steam will enter compartment. Once compartment has reached the pre-heat temperature (185°F) the timer will start. After the time selected has elapsed, buzzer will sound indicating the end of the cooking cycle. Steam generation will cease, Cook light will go out and Ready light will come on. To silence buzzer turn timer to its off position.

With ready pilot light on, preheat steamer compartment for one minute when the steamer is to be first used for the day or whenever the compartment is cold.

1. Close compartment doors and set timer to "1 minute".
2. When buzzer sounds, set timer to the "OFF" position.
3. Steamer is now ready for cooking.
4. With cooking compartment preheated and ready pilot light on, place pans of food to be cooked into compartment and shut door.
5. Set timer to cooking time desired. Cooking cycle may be interrupted at any time by opening door and resumed again by closing door.
6. When buzzer sounds, it indicates the end of the cooking cycle and that no more steam is entering the compartment. Cooking pilot light will go off and ready pilot light will come on. Buzzer must be shut off by turning the timer to its off position.

INSTALLATION AND OPERATION MANUAL,  
ELECTRIC CABINET BASE CONVECTION STEAMER, ECX-16, ECX-24

**4.0 OPERATING INSTRUCTIONS** (Continued)

**COOKER SECTION** (Continued)

	<b>CAUTION: An obstructed drain can cause personal injury or property damage.</b>
---	---

Frequently check that the compartment drain and plumbing is free of all obstructions. Never place food containers, food or food portion bags in the cooking compartment in such a way that the compartment drain becomes obstructed.

	<b>IMPORTANT: Each compartment is equipped with a removable drain screen. Frequently check the drain screen for accumulation of food particles. Should food particles accumulate against, or clog the drain screen, remove it, clean it thoroughly and then replace it in its original position.</b>
--	--

**SHUT DOWN**

1. To shut down cooking compartment, set timers to their OFF position and leave doors slightly open.
2. At the end of the day, the steam supply must be shut off. Open the door of cabinet base and turn off power switch. Open manual drain valve. If unit is equipped with automatic blowdown valve, it will open and drain the boiler.

	<b>CAUTION: If steam supply does not shut off during blowdown, immediately discontinue use of appliance and call for service.</b>
---	---

INSTALLATION AND OPERATION MANUAL,  
ELECTRIC CABINET BASE CONVECTION STEAMER, ECX-16, ECX-24

## **5.0 OPERATION INSTRUCTIONS FOR BOILERS WITH CSD-1 CONTROLS**

### **Start-up Procedure**

1. Close the manual blowdown valve, if so equipped.
2. Open cabinet door and turn “ON” power switch.

The green pilot light will come “ON.” Water will begin to enter the boiler. When enough water has entered the boiler, the (amber) “STANDBY” pilot light will come on.

3. Press the “RESET” switch to begin boiler operation. The “STANDBY” pilot light will go off and the boiler will begin operation.

### **Normal Boiler Operating Cycle**

#### **Water Fill Cycle**

On the initial filling of the boiler, the reset switch must be activated to initialize the safety lockout circuit. Once the water in the boiler has reached the proper level, the level control will stop the flow of water to the boiler. As water is consumed in the production of steam, the level control will supply additional water to the boiler.

#### **Firing Cycle**

The elements are operated by pressure sensing devices. On initial operation, the boiler should reach 14 psi in approximately 15 minutes. At this point, the operating pressure switch will open, de-energizing the elements. Thereafter the operating pressure switch will cycle the elements between 9 and 11 psi boiler pressure.

#### **Condensing Drain**

A thermostat is located in the drain assembly and is activated by the temperature of steam. The thermostat operates the cooling solenoid, supplying water to the drain to condense the steam.

#### **Automatic Blowdown Valve**

If the unit has an automatic blowdown valve, it is activated when the main power switch is activated. The boiler will be drained should the main power switch be turned “OFF.”

INSTALLATION AND OPERATION MANUAL,  
ELECTRIC CABINET BASE CONVECTION STEAMER, ECX-16, ECX-24

**5.0 OPERATION INSTRUCTIONS FOR BOILERS WITH CSD-1 CONTROLS** (Continued)

**SAFETY LOCKOUT CONDITIONS**

**High Temperature Condition**

A high temperature safety device is installed on the boiler. Should the temperature exceed the limit of this device, the boiler will be shut down and put in a state of lockout. The “TEMPERATURE” pilot light (red), and the “STANDBY” pilot light (amber), will come on.

**High Pressure Condition**

A high pressure safety switch is installed on the boiler. Should the pressure exceed the limit of this device, the boiler will be shut down and put into a state of lockout. The “PRESSURE” pilot light (red), and the “STANDBY” pilot light (amber), will come on. Should this device fail to operate, the safety relief valve will open.

**Low Water Condition**

A second low water safety cut off is supplied with the boiler. Should the water level fall below normal operating levels, the boiler will be shut down and put into a state of lockout. The “LOW WATER” pilot light (red), and the “STANDBY” pilot light (amber) will come on.

INSTALLATION AND OPERATION MANUAL,  
ELECTRIC CABINET BASE CONVECTION STEAMER, ECX-16, ECX-24

## 6.0 PERIODIC MAINTENANCE



**WARNING: Disconnect the unit from the power supply before cleaning or servicing appliance.**

Be sure to flush your boiler water level control daily. Failure to follow this procedure can cause the control to malfunction resulting in serious boiler damage.

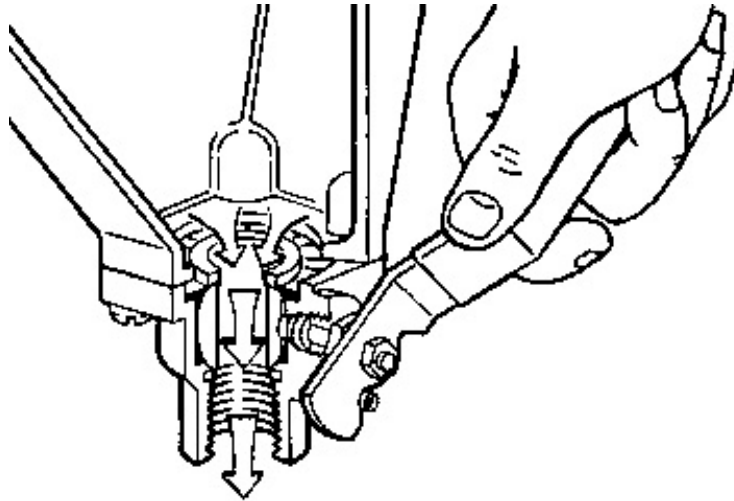

The Boiler Water Level Control installed on your boiler requires periodic maintenance. As boiler water circulates into the float chamber, sand, scale and other sediment may be deposited in the float chamber. While the chamber has been designed with a large accumulation bowl, it is necessary to flush the sediment from the chamber by blowing down the control so that the accumulation of sediment does not interfere with the movement of the float in the control. Control must be flushed at least once a day.



**CAUTION: Protect yourself. When flushing control, hot water and steam will flow out of the drain.**

When flushing control, note water level in gauge glass, allow the boiler to fill if necessary, and also to come up to temperature.

Before flushing control, note that water level in gauge glass is within operating range and the boiler pressure is at least 6 psi. While the boiler is being operated, open blowdown valve at bottom of control by rotating the handle counterclockwise about 1/4 turn to fully open the valve. Opening the blowdown valve also checks the cut-off operation. Float should drop shutting steam off, hot water and steam will flow out the drain flushing away sediment.

INSTALLATION AND OPERATION MANUAL,  
ELECTRIC CABINET BASE CONVECTION STEAMER, ECX-16, ECX-24

**6.0 PERIODIC MAINTENANCE** (Continued)



**CAUTION: If heater does not shut off during blowdown, immediately discontinue use of appliance and call for service.**

Continue draining water for about fifteen (15) seconds, from control until water is clean. Manually close valve. Recheck gauge glass. If water level has dropped significantly, wait for the boiler to restore water level and pressure and repeat if necessary.

1. Water level control should be opened daily to blow down sediment and scalant.
2. Observe that the water in gauge glass is clean and clear. Extreme murkiness in water indicates inadequate water quality.
3. Safety valve should be tripped during operation once a week to assure that it functions properly.
4. De-scaling is based on water quality and usage.



**CAUTION: Take extra caution when blowing down water level control or tripping safety valve as extreme hot water and live steam are present.**

**REMOVAL OF SCALE DEPOSITS**

This equipment should be installed with the Middleby TruH2O water treatment system which, when properly maintained can provide a scale-free environment for your steamer. However, because water quality can vary it is recommended that the steamer be checked every 90 to 120 days for scale build up. Regular maintenance should be carried out at this time.



INSTALLATION AND OPERATION MANUAL,  
ELECTRIC CABINET BASE CONVECTION STEAMER, ECX-16, ECX-24

**6.0 PERIODIC MAINTENANCE** (Continued)

**DESCALING BOILER**

If the boiler has been descaled, a new Anode should be installed in the boiler.





1. With boiler empty, close manual blowdown valve. If appliance is equipped with Automatic Blowdown, turn water supply to appliance OFF. Turn power switch ON. This will energize and close blowdown valve.
2. Remove 3/4" pipe plug from Brass Tee on front top of boiler.
3. Insert appropriate hose or tube through fitting and pour in (1/2) half gallon (U.S.) of CLR Descaling Solution or use the Optional Deliming assembly DPA-1 available from your dealer.
4. Replace 3/4" pipe plug securely.
5. Open water supply to appliance allowing water to fill boiler to required level.
6. Let appliance cycle, allow two hours for descaling and cleaning. DO NOT TURN ON STEAM to attached appliances or to upper compartment.
7. Open both the blowdown and low water level control valves for complete drainage. After boiler drains, close both valves.

Appliance equipped with automatic blowdown - turn OFF power switch and open low water control valve. This will allow complete drainage. Once drained close water level control valve.

8. Turn appliance switch ON. When boiler is completely filled turn power switch OFF. This will rinse and drain boiler. Appliances with manual blowdown valve must be opened to drain.
9. Complete Step 8 twice to assure boiler is completely rinsed.
10. Appliance is now ready for use.

INSTALLATION AND OPERATION MANUAL,  
ELECTRIC CABINET BASE CONVECTION STEAMER, ECX-16, ECX-24

7.0 CLEANING INSTRUCTIONS

	<b>CAUTION: Never spray water into electric controls.</b>
	<b>CAUTION: Do not use cleaning agents that are corrosive.</b>
	<b>CAUTION: Live steam and accumulated hot water in the compartment may be released when the door is opened.</b>
	<b>CAUTION: Disconnect the power supply during cleaning or servicing.</b>

1. Keep exposed cleanable areas of unit clean at all times.
2. Thoroughly wash steamer cavities, door liners, and pan racks at the end of each day or as required with a mild detergent and water to prevent bacterial growth and odors.
3. Remove drain screens from inside compartment drains. Using a plastic bottle brush and mild detergent, clean inside the drain opening ensuring there is no food residue or blockage. Clean the drain screen and replace in its original position.
4. Wash gasket sealing surface with mild detergent to remove harmful food acids and rinse.
5. Rinse entire unit and dry. **DO NOT GET WATER** in electrical box or any electrical component.

INSTALLATION AND OPERATION MANUAL,  
ELECTRIC CABINET BASE CONVECTION STEAMER, ECX-16, ECX-24

8.0 ADJUSTMENTS

TO CALIBRATE PRESSURE SWITCHES

**NOTE: Pressure switches are factory set. Calibration is only required if pressure switches are replaced or if adjustment is required.**

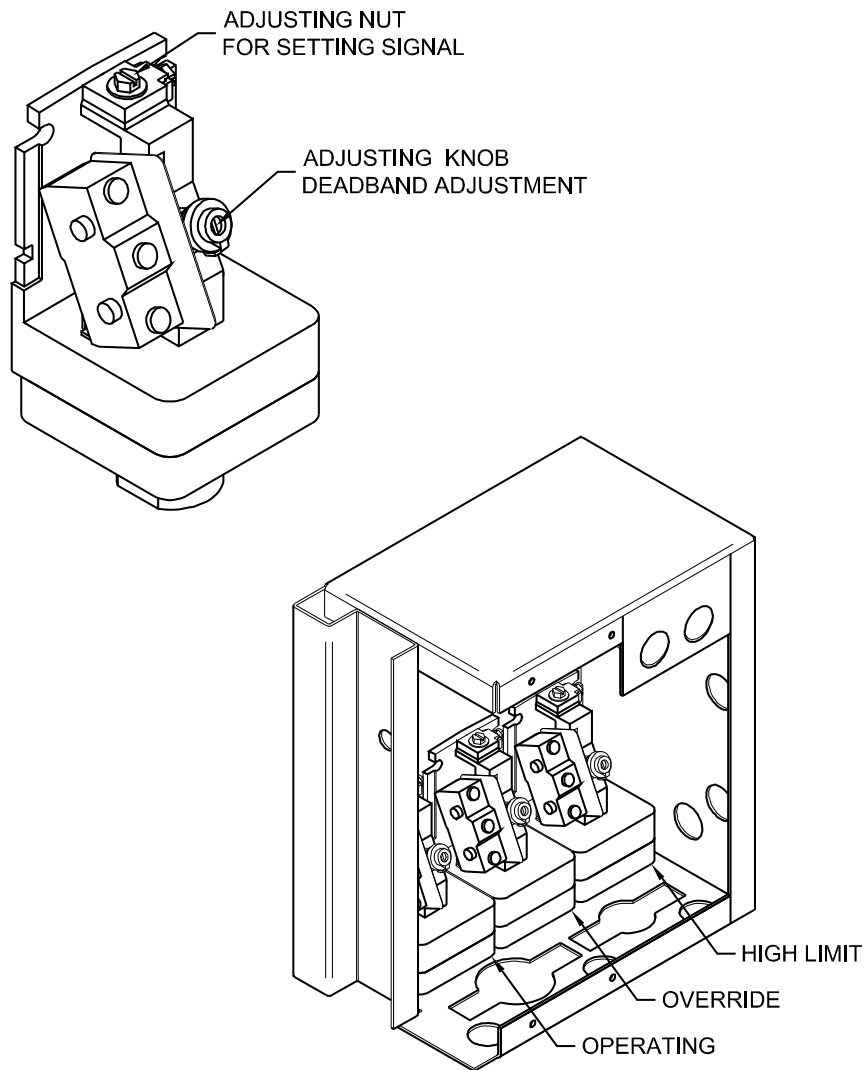

INSTALLATION AND OPERATION MANUAL,  
ELECTRIC CABINET BASE CONVECTION STEAMER, ECX-16, ECX-24

8.0 **ADJUSTMENTS** (Continued)

**TO CALIBRATE PRESSURE SWITCHES** (Continues)



**CAUTION: Adjusting knob and nut will turn easily until they hit a stop. Do not over torque. Over torquing may cause damage.**

1. Turn the adjusting knob clockwise to the deadband to maximum.
2. Turn the adjusting nut clockwise to maximum.
3. Adjust in the following sequence:
  - High limit pressure switch.
  - Override pressure switch. (if equipped).
  - Operating pressure switch.
  - Use relief valve to release pressure from boiler for setting adjustments.

High Limit Pressure Switches

Allow pressure to build until unit shuts off. This should occur at 15 PSI. Set the adjusting nut to switch off at 14.5 PSI on the gauge.

Override Pressure Switches

Set the adjusting nut to switch off at 13 PSI on the gauge.

Operating Pressure Switches

Set the high signal to switch off at 11 PSI on the gauge.

4. Release pressure in boiler below 9 PSI. The boiler should fire and once the pressure has reached 11 PSI, the boiler should shut off. Repeat this process several times to make sure boiler operates between 9 and 11 PSI.

Once completed, pressure switches have been calibrated.

INSTALLATION AND OPERATION MANUAL,  
ELECTRIC CABINET BASE CONVECTION STEAMER, ECX-16, ECX-24

## 9.0 TROUBLESHOOTING



**NOTICE:** Contact the factory, the factory representative or local service company to perform maintenance and repairs. Refer to warranty terms.



**NOTICE:** At least twice a year have an authorized service person clean and adjust the unit for maximum performance.

### DOOR LEAKS

1. Check for damage to door gasket.
2. Compartment drain opening or associated piping may be blocked.

### WATER ACCUMULATES IN THE COMPARTMENT

1. Compartment drain screen clogged. Remove and clean thoroughly and then replace.

### SAFETY VALVE BLOWS

1. Defective safety valve.
2. Pressure too high. Pressure switch requires adjustment (lower) or may be defective.

### WATER NOT BEING SUPPLIED TO BOILER

1. Water supply is "OFF".
2. Defective water fill solenoid.
3. Water level control clogged or defective, unable to operate fill valve.
4. Check drain valve is closed.
5. Supply water pressure too low.

INSTALLATION AND OPERATION MANUAL,  
ELECTRIC CABINET BASE CONVECTION STEAMER, ECX-16, ECX-24

**9.0 TROUBLESHOOTING** (Continued)

**AUTOMATIC BLOWDOWN VALVE DOES NOT DRAIN**

1. Defective blowdown valve.
2. Boiler build up of scalant clogging drain lines and valve.

**BOILER ACHIEVES PRESSURE SLOWER THAN NORMAL**

1. Heavy build up of lime on elements.
2. Loose element connections.