



IMPORTANT FOR FUTURE REFERENCE

Please complete this information and retain this manual for the life of the equipment:

Model #: _____

Serial #: _____

Date Purchased: _____

INSTALLATION & OPERATION MANUAL

**Direct Steam Kettles on Gas Boiler Cabinet Base
GMT-6-(6,10,12) GMT-10-(6,10,12) GMT-12-(6,10,12)**

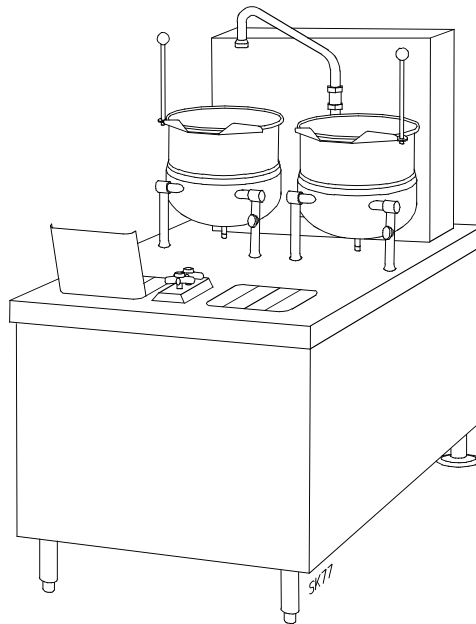

⚠ WARNING

Improper installation, adjustment, alteration, service or maintenance can cause property damage, injury or death. Read the installation, operating and maintenance instructions thoroughly before installing or servicing this equipment.

CROWN FOOD SERVICE EQUIPMENT

 A Middleby Company

70 Oakdale Road, Downsview (Toronto) Ontario, Canada, M3N 1V9

Telephone: 919-762-1000 www.crownsteamgroup.com

Printed in Canada



INSTALLATION AND OPERATION MANUAL, DIRECT STEAM KETTLES MOUNTED ON GAS
BOILER CABINET BASE, GMT-6, GMT-10, GMT-6-6, GMT-10-6, GMT-10-10

IMPORTANT NOTES FOR INSTALLATION AND OPERATION

It is recommended that this manual be read thoroughly and that all instructions be followed carefully.



This is the safety alert symbol. It is used to alert you to potential personal injury hazards. Obey all safety messages that follow this symbol to avoid possible injury or death.



FOR YOUR SAFETY: Do not store or use gasoline or other flammable vapours or liquids in the vicinity of this or any other appliance.

PURCHASER: Instructions to be followed in the event that the operator of this appliance smells gas must be posted in a prominent location. This information shall be obtained by consulting the local gas supplier.

Do not attempt to operate this unit in the event of a power failure.

Keep the appliance area free and clear from combustibles.

Do not obstruct the flow of combustion and ventilation air.

Adequate clearances must be maintained for servicing and proper operation.



WARNING: Improper installation, operation, adjustment, alteration, service or maintenance can cause property damage, injury or death. Read the installation, operating and maintenance instructions thoroughly before installing, operating or servicing this equipment.



NOTICE: Contact the factory, the factory representative or local service company to perform maintenance and repairs.

This manual should be retained for future reference.

Intended for commercial use only. Not for household use.

INSTALLATION AND OPERATION MANUAL, DIRECT STEAM KETTLES MOUNTED ON GAS
BOILER CABINET BASE, GMT-6, GMT-10, GMT-6-6, GMT-10-6, GMT-10-10

TABLE OF CONTENTS

DESCRIPTION	PAGE
1.0 Service Connections	4
2.0 Installation Instructions	10
3.0 Operation Instructions	13
4.0 Operation Instructions for CSD-1 Equipped Units	16
5.0 Periodic Maintenance	19
6.0 Adjustments	22
7.0 Troubleshooting	24
8.0 Introduction - Direct Steam Kettles	26
9.0 Operating Procedures	27
10.0 Cleaning Procedures	28
11.0 Preventive Maintenance	29

INSTALLATION AND OPERATION MANUAL, DIRECT STEAM KETTLES MOUNTED ON GAS BOILER CABINET BASE, GMT-6, GMT-10, GMT-6-6, GMT-10-6, GMT-10-10

SERVICE CONNECTIONS

- ⚡ – **ELECTRICAL CONNECTION:** $\phi 1/2"$ O.D. conduit connection to controls.
120 Volts single phase with grounding wire required unless other wise specified.
- 💧 – **DRAIN:** 2"IPS piped to open floor drain. No Solid Connection.
- 💧 – **COLD WATER:** $3/8"$ O.D. tubing at 25–50 PSI(170–345 kPa)
- 💧 – **GAS CONNECTION:** $3/4"$ IPS supply line required.
Natural Gas : min.4" (102mm) Water Column.
Propane: min.11" (279mm) Water Column.
- 🔥 – **STEAM TAKE-OFF CONNECTION:** $3/4"$ IPS optional to operate adjacent equipment.

WATER QUALITY STATEMENT

Water quality is the major factor affecting the performance of your appliance. If you are unsure of water quality, consult a local water treatment specialist and have the water analyzed. Your water supply must be within these general guidelines:

Total dissolved solids	Less than 60 PPM
Total alkalinity	Less than 20 PPM
Silica	Less than 13 PPM
Chlorine	Less than 1.5 PPM
pH Factor	7.0–8.5

Water which fails to meet these standards should be treated by installation of water conditioner.

FAILURE OR MALFUNCTION OF THIS APPLIANCE DUE TO POOR WATER QUALITY IS NOT COVERED UNDER WARRANTY.

MODEL	BOILER INPUT		AVAILABLE CABINET WIDTH	
	BTU/HOUR	kw/HOUR	24"	36"
GMT-6	140,000	41.0	YES	YES
GMT-10	200,000	58.6	YES	YES
GMT-12	250,000	73.3	NO	YES
	300,000	87.9	NO	YES

DIMENSIONS

MODEL	CAPACITY	UNITS	A	B	C	D	E	F	G	H	J	K	L	M
GMT-6	6 gallons	inches	12	14.5	56.75	3	2.5	5.75	4.75	3.5	11	8	9	12
	23 litres	mm	305	368	1441								229	305
GMT-10	10 gallons	inches	16	15	55.75	76	64	146	121	89	279	203	6	12
	38 litres	mm	406	381	1416								152	305
GMT-12	12 gallons	inches	16	17	57.75								6	12
	45 litres	mm	406	432	1469								152	305

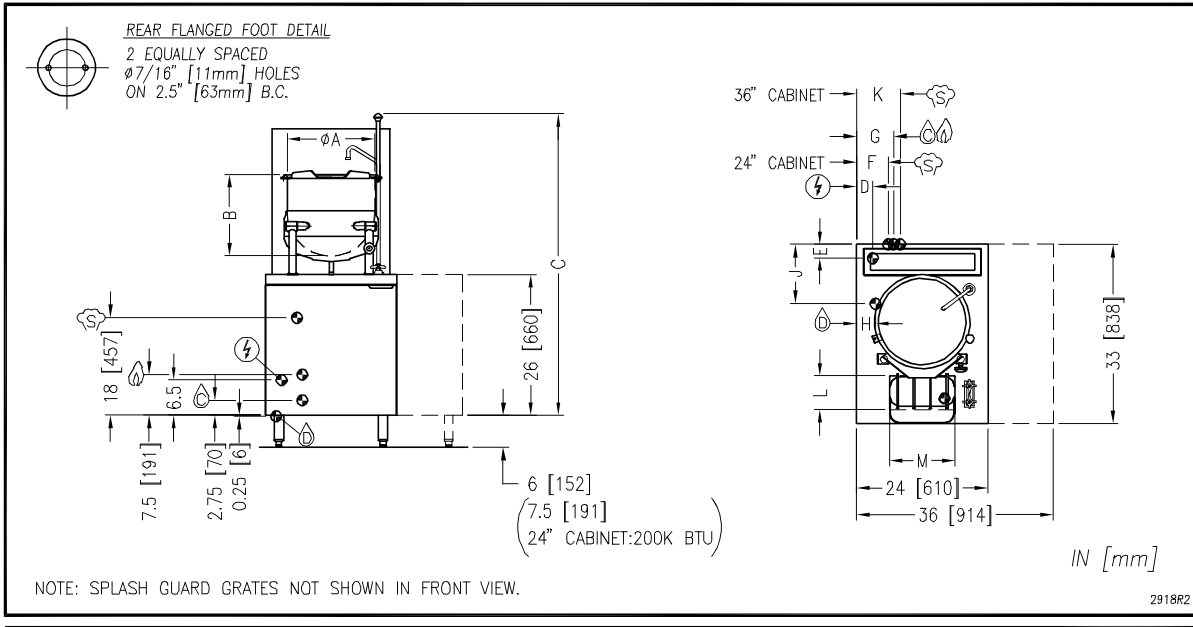

As continued product improvement is a policy of Crown, specifications are subject to change without notice.

INSTALLATION AND OPERATION MANUAL, DIRECT STEAM KETTLES MOUNTED ON GAS BOILER CABINET BASE, GMT-6, GMT-10, GMT-6-6, GMT-10-6, GMT-10-10

SERVICE CONNECTIONS

- ⚡ - ELECTRICAL CONNECTION: 1/2" conduit connection to controls.
120 Volts single phase with grounding wire required unless otherwise specified.
- 💧 - DRAIN: 2"IPS piped to open floor drain. No Solid Connection.
- 💧 - COLD WATER: 3/8" O.D. tubing at 25–50 PSI(170–345 kPa). (140,000 BTU BOILER)
- 💧 - GAS CONNECTION: 3/4"IPS supply line required.
- ⚡ - STEAM TAKE-OFF CONNECTION: 3/4"IPS optional to operate adjacent equipment.

WATER QUALITY STATEMENT

WATER QUALITY IS THE MAJOR FACTOR AFFECTING THE PERFORMANCE OF YOUR APPLIANCE. IF YOU ARE UNSURE OF WATER QUALITY, CONSULT A LOCAL WATER TREATMENT SPECIALIST AND HAVE THE WATER ANNALYZED. YOUR WATER SUPPLY MUST BE WITHIN THESE GENERAL GUIDE LINES:

TOTAL DISSOLVED SOLIDS	LESS THAN 60 PPM
TOTAL ALKALINITY	LESS THAN 20 PPM
SILICA	LESS THAN 13 PPM
CHLORINE	LESS THAN 1.5 PPM
pH FACTOR	7.0–8.5

WATER WHICH FAILS TO MEET THESE STANDARDS SHOULD BE TREATED BY INSTALLATION OF A WATER CONDITIONER.

FAILURE OR MALFUNCTION OF THIS APPLIANCE DUE TO POOR WATER QUALITY IS NOT COVERED UNDER WARRANTY.

MODEL	BOILER INPUT	
	BTU/HOUR	kW/HOUR
GMT-6-6	140,000	41.0
	200,000	58.6
	250,000	73.3
	300,000	87.9

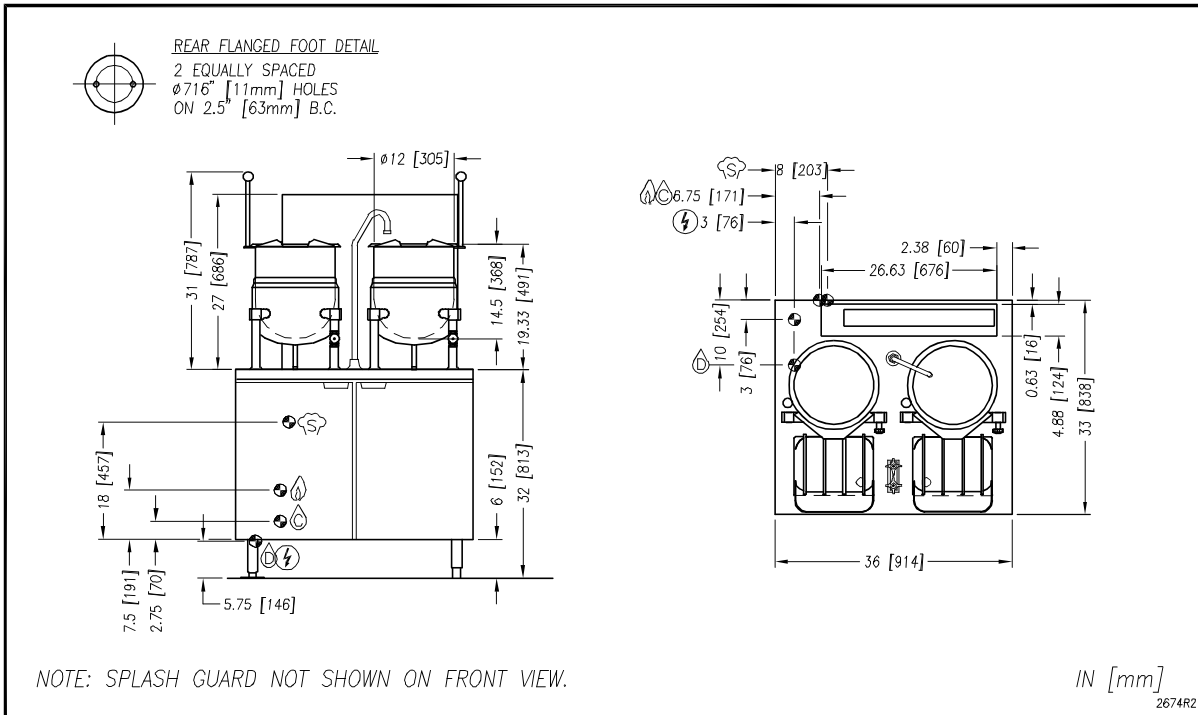

As continued product improvement is a policy of Crown, specifications are subject to change without notice.

INSTALLATION AND OPERATION MANUAL, DIRECT STEAM KETTLES MOUNTED ON GAS BOILER CABINET BASE, GMT-6, GMT-10, GMT-6-6, GMT-10-6, GMT-10-10

SERVICE CONNECTIONS

- ⚡ - **ELECTRICAL CONNECTION:** 1/2" conduit connection to controls.
120 Volts single phase with grounding wire required unless other wise specified.
- Ⓛ - **DRAIN:** 2"IPS piped to open floor drain. No Solid Connection.
- Ⓛ - **COLD WATER:** 3/8" O.D. tubing at 25–50 PSI(170–345 kPa). (140,000 BTU Boiler)
- Ⓛ - **GAS CONNECTION:** 3/4"IPS supply line required.
Natural Gas: min. 4" (102mm) Water Column.
Propane: min. 11" (279mm) Water Column.
- Ⓛ - **STEAM TAKE-OFF CONNECTION:** 3/4"IPS optional to operate adjacent equipment.

WATER QUALITY STATEMENT

WATER QUALITY IS THE MAJOR FACTOR AFFECTING THE PERFORMANCE OF YOUR APPLIANCE. IF YOU ARE UNSURE OF WATER QUALITY, CONSULT A LOCAL WATER TREATMENT SPECIALIST AND HAVE THE WATER ANNALYZED. YOUR WATER SUPPLY MUST BE WITHIN THESE GENERAL GUIDE LINES:

TOTAL DISSOLVED SOLIDS	LESS THAN 60 PPM
TOTAL ALKALINITY	LESS THAN 20 PPM
SILICA	LESS THAN 13 PPM
CHLORINE	LESS THAN 1.5 PPM
pH FACTOR	7.0–8.5

WATER WHICH FAILS TO MEET THESE STANDARDS SHOULD BE TREATED BY INSTALLATION OF A WATER CONDITIONER.

FAILURE OR MALFUNCTION OF THIS APPLIANCE DUE TO POOR WATER QUALITY IS NOT COVERED UNDER WARRANTY.

MODEL	BOILER INPUT	
	BTU/HOUR	kW/HOUR
GMT-10-6	140,000	41.0
	200,000	58.6
	250,000	73.3
	300,000	87.9

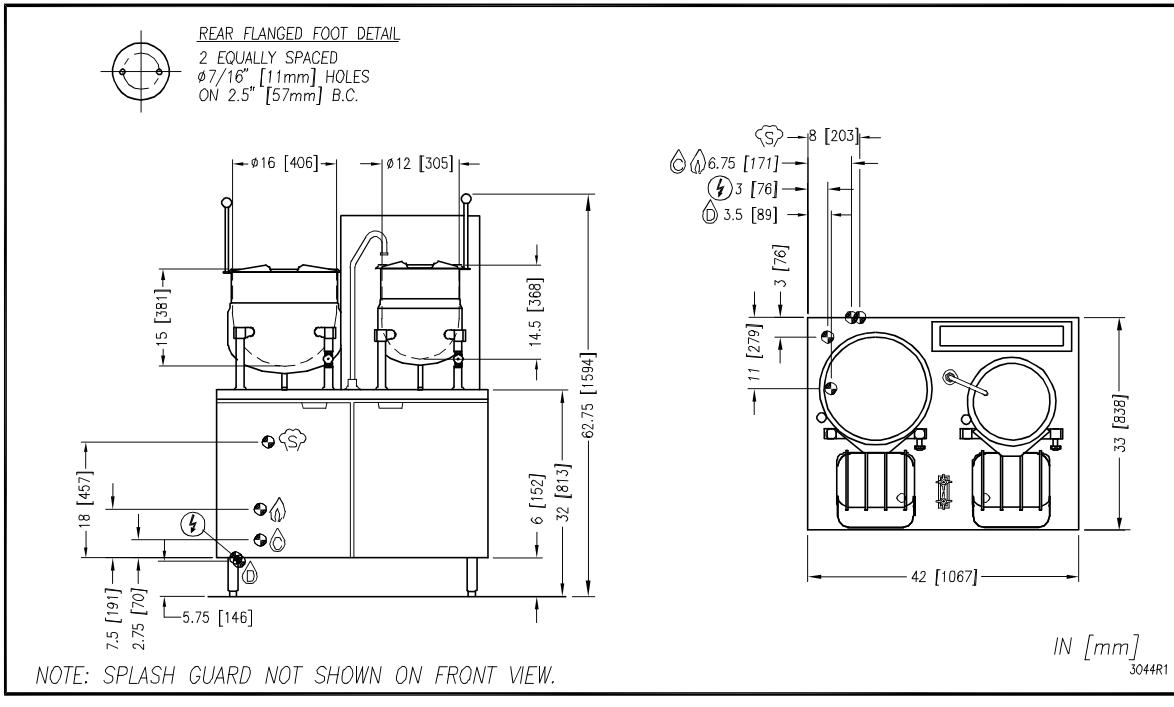

As continued product improvement is a policy of Crown, specifications are subject to change without notice.

INSTALLATION AND OPERATION MANUAL, DIRECT STEAM KETTLES MOUNTED ON GAS BOILER CABINET BASE, GMT-6, GMT-10, GMT-6-6, GMT-10-6, GMT-10-10

SERVICE CONNECTIONS

- Ⓛ – **ELECTRICAL CONNECTION:** $\phi 1/2"$ O.D. conduit connection to controls.
120 Volts single phase with grounding wire required unless other wise specified.
- Ⓛ – **DRAIN:** 2"IPS piped to open floor drain. No Solid Connection.
- Ⓛ – **COLD WATER:** $3/8"$ O.D. tubing at 25–50 PSI(170–345 kPa)
- Ⓛ – **HOT WATER:** $3/8"$ O.D. tubing at 25–50 PSI(170–345 kPa)
- Ⓛ – **GAS CONNECTION:** $3/4"$ IPS supply line required.
Natural Gas : min.4" (102mm) Water Column.
Propane: min.11" (279mm) Water Column.
- Ⓛ – **STEAM TAKE-OFF CONNECTION:** $3/4"$ IPS optional to operate adjacent equipment.

WATER QUALITY STATEMENT

Water quality is the major factor affecting the performance of your appliance. If you are unsure of water quality, consult a local water treatment specialist and have the water analyzed. Your water supply must be within these general guidelines:

Total dissolved solids	Less than 60 PPM
Total alkalinity	Less than 20 PPM
Silica	Less than 13 PPM
Chlorine	Less than 1.5 PPM
pH Factor	7.0–8.5

Water which fails to meet these standards should be treated by installation of water conditioner.

FAILURE OR MALFUNCTION OF THIS APPLIANCE DUE TO POOR WATER QUALITY IS NOT COVERED UNDER WARRANTY.

MODEL	BOILER INPUT	
	BTU/HOUR	KW/HOUR
GMT-10-10	140,000	41.0
	200,000	58.6
	250,000	73.3
	300,000	87.9

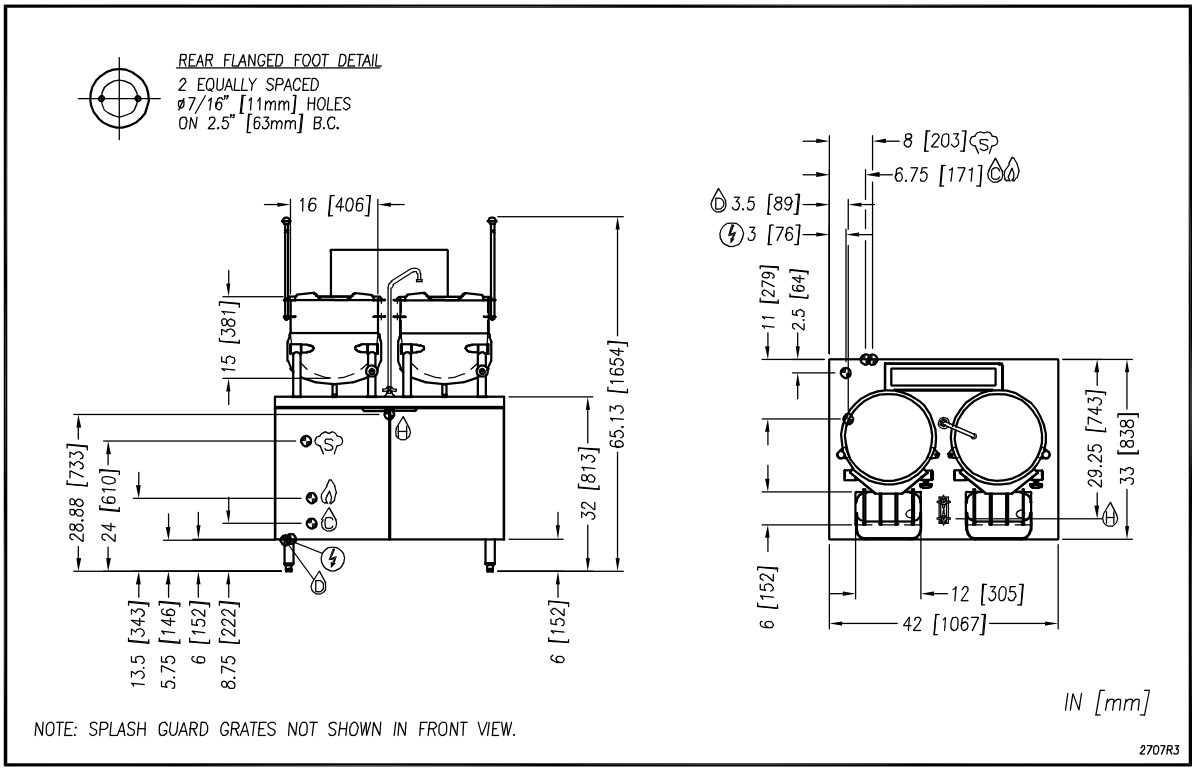

As continued product improvement is a policy of Crown, specifications are subject to change without notice.

INSTALLATION AND OPERATION MANUAL, DIRECT STEAM KETTLES MOUNTED ON GAS BOILER CABINET BASE, GMT-6, GMT-10, GMT-6-6, GMT-10-6, GMT-10-10

GENERAL

Direct steam jacketed kettle(s), pressure vessels of a double wall stainless steel construction forming a steam chamber (jacket) enveloping the lower two thirds of the kettle bowl surface. Kettles are mounted on a modular cabinet base housing a gas boiler designed to ASME Code and approved as a steam heating boiler restricted to operation at pressure not to exceed 15 psi. The gas boiler may be in a 24 inch cabinet base rated at 140,000 or 200,000 BTU, or 36 inch or 42 inch cabinet base rated at 200,000, 250,000 or 300,000 BTU, operational on Natural or Propane gas. Boilers may be optional with electronic ignition and CSD-1 controls. All models are suffixed with either -6 or -10 to indicate the capacity of the kettle in US gallons.

UNPACKING

Immediately after unpacking, check for possible shipping damage. If the appliance is found to be damaged, save the packaging material and contact the carrier within 15 days of delivery.

Before installing, verify that the gas (natural or propane), the elevation from sea level and the electrical supply agree with the specification on the data plate. NOTE: If this appliance is being installed above 2000 feet altitude, contact your authorized service office to assure that the proper orifice size for your elevation has been installed.

1.0 SERVICE CONNECTIONS

PLUMBING CONNECTIONS



WARNING: Plumbing connections must comply with applicable sanitary, safety, and plumbing codes.

WATER SUPPLY CONNECTION

The incoming cold water supply connection, at the rear of the appliance cabinet, requires 3/8" tubing and water pressure of 25 - 50 psi. A manual shut-off valve must be provided convenient to the appliance; this valve should be open when the boiler is in operation. Incoming hot water connection (1/2" (13 mm)) nominal tube for kettle fill faucet must be installed. See Service Connections.

FAILURE OR MALFUNCTION OF THIS APPLIANCE DUE TO POOR WATER QUALITY IS NOT COVERED UNDER WARRANTY. SEE WATER QUALITY STATEMENT, PAGE 4.

INSTALLATION AND OPERATION MANUAL, DIRECT STEAM KETTLES MOUNTED ON GAS
BOILER CABINET BASE, GMT-6, GMT-10, GMT-6-6, GMT-10-6, GMT-10-10

DRAIN CONNECTION

The steamer drain (2" IPS) should be piped to a floor drain near the steamer. There should be no solid drain connection; an "open gap" between the steamer and the floor drain is required.

GAS CONNECTION

1. The data plate on the cabinet door of the boiler indicates the type of gas your unit is equipped to burn. DO NOT connect to any other gas type.

Keep the appliance area free and clear from combustible substances. Do not obstruct the flow of combustion and ventilation air.

2. A 3/4" NPT line is provided at the rear for the connection. Each boiler is equipped with an internal pressure regulator which is set at 3.5" W.C. manifold pressure for natural gas or 10.5" W.C. for LP gas. Use the 1/8" pipe tap on the burner manifold for checking pressure.

An adequate gas supply is necessary. Undersized or low pressure lines will restrict the volume of gas required for satisfactory performance. A steady supply pressure, between 7" W.C. and 14" W.C. for natural gas and 11" W.C. and 14" W.C. for propane gas is recommended. With all units operating simultaneously, the manifold pressure on all units should not show any appreciable drop. Fluctuations of more than 25% on natural gas, and 10% on propane gas, will create pilot problems and affect burner operating characteristics.

NOTICE: If this equipment is being installed at over 2,000 feet altitude and was not so specified on order, contact service department. Failure to install with proper orifice sizing may void the warranty.

Contact your gas company for correct supply line sizes.

Purge the supply line to clean out any dust, dirt, or foreign matter before connecting the line to the unit.



CAUTION: The pipe thread compound used when installing pipes must be a type that is resistant to the action of liquified petroleum or propane gases.

Codes require that a gas shut-off valve be installed in the gas line prior to the steamer. Make sure the pipes are clean and free of obstructions, dirt, and piping compound.

INSTALLATION AND OPERATION MANUAL, DIRECT STEAM KETTLES MOUNTED ON GAS
BOILER CABINET BASE, GMT-6, GMT-10, GMT-6-6, GMT-10-6, GMT-10-10



WARNING: Never use an open flame to check for gas leaks. Check all connections for leaks using soapy water before use.

ELECTRICAL CONNECTIONS



WARNING: Do not connect the appliance to the electrical supply until after the gas connection has been made.

Refer to the electrical diagram located inside cabinet on door.

When making electrical connections, use copper wire suitable for at least 200°F (90°C). The steamer must be grounded in accordance with the National Electrical Code or applicable local codes.

2.0 INSTALLATION INSTRUCTIONS

LOCATION

The installation location must be kept free and clear of combustibles. Do not obstruct the flow of combustion and ventilation air. Clearance from combustible construction must be a minimum of 3 inches from the sides and 6 inches from the back. The appliance should be installed on a noncombustible floor. Provide adequate clearances for cleaning, maintenance, service and proper operation.

Sufficient air should be allowed to enter the room to compensate for the amount of air removed by any ventilating system and for combustion of the gas burners. Do not obstruct the air flow into and around the appliance. Do not obstruct the flow of flue gases from the flue duct located at the rear and above the cabinet. Position the appliance in its final location. Check that there are sufficient clearances to service the controls, for door swings, etc., so there will be no problem in making the required supply and drain connections.

Allow enough space between any other piece of equipment or a wall for service access. Service on the cabinet base may require access to the left and/or right side panels.

INSTALLATION AND OPERATION MANUAL, DIRECT STEAM KETTLES MOUNTED ON GAS
BOILER CABINET BASE, GMT-6, GMT-10, GMT-6-6, GMT-10-6, GMT-10-10

LEVELLING AND ANCHORING THE CABINET

1. Place appliance in the installation position.
2. Place a carpenter's level on top of the appliance and turn the adjustable feet to level side-to-side and front-to-back.
3. Mark hole locations on the floor through the anchoring holes provided in the rear flanged adjustable feet.
4. Remove appliance from installation position and drill holes in locations marked on the floor. Insert proper anchoring devices (not supplied).
5. Place appliance back in the installation position.
6. Place carpenter's level on top appliance and re-level side-to-side and front-to-back.
7. Bolt and anchor appliance securely to the floor.
8. Seal bolts and flanged feet with Silastic or equivalent compound.

INSTALLATION CODES AND STANDARDS

The boiler must be installed in accordance with:

Gas installation to conform to local codes, or in absence of local codes, with the National Fuel Gas Code - ANSI Z223.1/NFPA 54. In Canada installation to be in accordance with CSA B149.1 Natural Gas and Propane Installation Code.

1. The appliance and its individual shut off valve must be disconnected from the gas supply piping system during any pressure testing of that system at pressures in excess of ½ psig (3.5 kPa).
2. The appliance must be isolated from the gas supply piping system by closing its individual manual shut off valve during any pressure testing of the gas supply piping system at test pressures equal to or less than ½ psig (3.5 kPa).

Electrical grounding must be provided in accordance with local codes, or in the absence of local codes, with the National Electrical Code ANSI/NFPA 70. In Canada, installation must be in accordance with the Canadian Electrical Code CSA C22.2.

INSTALLATION AND OPERATION MANUAL, DIRECT STEAM KETTLES MOUNTED ON GAS
BOILER CABINET BASE, GMT-6, GMT-10, GMT-6-6, GMT-10-6, GMT-10-10

INSTALLATION CODES AND STANDARDS (Continued)

WIRING DIAGRAM FOR APPLIANCE IS LOCATED INSIDE CABINET DOOR.

EXHAUST FANS AND CANOPIES:

Canopies are set over ranges, ovens, kettles, etc., for ventilation purposes. It is recommended that a canopy extend 6 inches past the appliance and be located 6 feet 6 inches from the floor. Filters should be installed at an angle of 45 degrees or more with the horizontal. This position prevents dripping of grease and facilitates collecting the run-off grease in a drip pan, usually installed with the filter. A strong exhaust fan tends to create a vacuum in the room and may interfere with burner performance or may extinguish pilot flames. Makeup air openings approximately equal to the fan area will relieve such vacuum. In case of unsatisfactory performance on an appliance, check with the exhaust fan in the "OFF" position.

INSTALLATION AND OPERATION MANUAL, DIRECT STEAM KETTLES MOUNTED ON GAS BOILER CABINET BASE, GMT-6, GMT-10, GMT-6-6, GMT-10-6, GMT-10-10

3.0 OPERATION INSTRUCTIONS

	WARNING: Do not force the gas control knob. Use only your hand to turn the gas control knob. Never use any tool. If the gas control knob will not operate by hand the gas control should be replaced by a qualified service technician.
---	--

	WARNING: Do not disassemble the gas control; it contains no replaceable components. Attempted disassembly or repair may damage the gas control.
---	--

	WARNING: In the event of main burner ignition failure, a 5 minute purge period must be observed prior to re-establishing ignition source.
---	--

	CAUTION: If you smell gas during the lighting procedure, immediately shut off the gas supply until the leak has been corrected.
--	--

For CSD-1 equipped boilers, see section 4.0 Operation Instructions for CSD-1 Equipped Boiler.

BOILER CONTROLS (Inside Cabinet)

- Main Power Switch
 - ON fills the boiler tank and turns the boiler controls on. You should allow 20 minutes to fill the tank and generate steam.
 - OFF shuts off the boiler controls and opens the automatic blowdown valve (if so equipped), emptying the boiler tank and releasing water and steam to the drain. This should be done at least once daily to remove sediment, lime or scale.
- Pilot Light
 - Indicates main power is ON.
- Boiler Pressure Gauge
 - Should read 9 - 11 psi during operation, 0 psi during shutdown.
- Water Level Sight Glass
 - Observe level of water in the boiler and water quality. Murkiness in the water indicates inadequate water quality; the owner must supply proper water to the boiler. See page 4 Water Quality Statement.

INSTALLATION AND OPERATION MANUAL, DIRECT STEAM KETTLES MOUNTED ON GAS
BOILER CABINET BASE, GMT-6, GMT-10, GMT-6-6, GMT-10-6, GMT-10-10

BOILER CONTROLS (Inside Cabinet) - Continued

Water Level Control - While ON, briefly open the water level control once each week to remove any sediment that might accumulate.

Safety Valve - This valve will release (pop off) if the boiler has too much pressure. Once a week, this valve should be tripped during operation to make sure it functions properly.



WARNING: In the event you smell gas, shut down equipment at the main shut off valve and contact the local gas company or gas supplier for service.

1. START UP - BOILER OPERATION WITH STANDING PILOT IGNITION

Open manual gas shut off supply valve and if the appliance has a manual blowdown valve, close it. Open cabinet door and turn ON power switch located on left side. Green pilot light will come on, water will begin to enter boiler and required water level will be reached in about three minutes. Observe water gauge glass to verify.

The dial on the combination gas control valve has three positions (ON-PILOT-OFF) for manual gas control of main burners and pilot. Turn DIAL to PILOT. Depress dial and light pilot burner located on centre main burner of boiler. Maintain dial in depressed position for about 30 seconds and release. Observe that the pilot burner flame stays on. If at any time the flame should become extinguished, a 5 minute period of complete shut off of gas supply is required before relighting.

Turn dial to ON and burners should ignite. Steam generation will now commence and be completed in approximately 15 minutes. Steam generation should reach approximately 11 psi as indicated on the pressure gauge on the boiler.

2. START UP - BOILER OPERATION WITH ELECTRONIC IGNITION

Open manual gas supply valve.

Open cabinet door and turn main power switch ON. Green pilot light will come on, water will begin to enter boiler and required water level will be reached in about 3 minutes. Observe water gauge sight glass to verify.

INSTALLATION AND OPERATION MANUAL, DIRECT STEAM KETTLES MOUNTED ON GAS
BOILER CABINET BASE, GMT-6, GMT-10, GMT-6-6, GMT-10-6, GMT-10-10

2. START UP - BOILER OPERATION WITH ELECTRONIC IGNITION (Continued)

The dial on the gas combination control valve has two positions (ON and OFF).

ON - [Rotated counterclockwise] permits gas to flow to the pilot and main burner.

OFF - [Rotated clockwise] prevents gas flow to pilot and main burner.

NOTE: Units are shipped with the control in the ON position.

With the gas control valve, power switch and water supply all ON, water begins entering the boiler and gas flows to the pilot: Spark will begin in 2 to 3 seconds. If the pilot fails to light in 90 seconds, the control will provide 100% lockout. If this occurs: Wait 5 minutes, then turn power switch off for one minute before turning power switch back on.

Once the pilot is lit and the required water level has been reached, the main burners will ignite. Burner will cycle to meet the steam pressure required. Steam pressure should reach approximately 11 psi as indicated on the pressure gauge on the boiler.

DAILY SHUT DOWN

Turn power switch off.

Open manual blowdown valve if so equipped.

COMPLETE BOILER SHUT DOWN

If boiler is not intended to be operated for a lengthy period of time, shut off all power, gas and water supplies to the appliance. Open manual blowdown valve if so equipped.

4.0 OPERATION INSTRUCTIONS FOR CSD-1 EQUIPPED UNITS

Initial Start-Up Procedure

1. Open the manual gas shut-off supply valve.
2. Close the manual blowdown valve, if so equipped.
3. Light the pilot burner.

The dial on the combination gas valve has three positions (ON-OFF-PILOT) for manual gas control of main burners and pilot burner. Turn the dial to PILOT. Depress the dial and light the pilot burner on the centre burner of boiler. Maintain the dial in depressed position for about 30 seconds and release. Observe that the pilot flame stays ON. Turn dial to "ON".

4. Open cabinet door and turn "ON" the power switch. The green pilot light will come "ON". Water will begin to enter the boiler. When enough water has entered the boiler the (amber) "STAND BY" pilot light will come on.
5. Press the "RESET" switch to begin boiler operation. The "STAND BY" pilot light will go off and the boiler will begin operation.

If at anytime the flame should become extinguished, a five (5) minute purging is required before relighting is attempted.

Daily Startup Procedure

1. Close the manual blowdown valve, if so equipped.
2. Examine that the pilot burner flame is burning. If the pilot burner is out, a five (5) minute period of complete gas supply shut off is required before relighting. Follow initial start up instructions above.
3. Open cabinet door and turn "ON" the power switch. The green pilot light will come "ON". Water will begin to enter the boiler. When enough water has entered the boiler the (amber) "STAND BY" pilot light will come on.
4. Press the "RESET" switch to begin boiler operation. The "STAND BY" pilot light will go off and the boiler will begin operation.

INSTALLATION AND OPERATION MANUAL, DIRECT STEAM KETTLES MOUNTED ON GAS
BOILER CABINET BASE, GMT-6, GMT-10, GMT-6-6, GMT-10-6, GMT-10-10

4.0 OPERATION INSTRUCTIONS FOR CSD-1 EQUIPPED UNITS (Continued)

Daily Shutdown Procedure

1. Turn "OFF" the power switch. Observe that the burners go off.
2. Open the manual blowdown valve, if so equipped. If the appliance is equipped with an automatic blowdown solenoid valve, the boiler's contents, water and steam, will be blown out and exhausted through the appliance drain. The cold water solenoid valve will be activated.

Complete Shutdown Procedure

If the appliance is not intended to be operational for a lengthy period, then shut it down completely.

1. Open the manual blowdown valve, is so equipped.
2. Shut off all supplies of power, gas and water to the appliance.

Normal Boiler Operating Cycle

Water Fill Cycle

On the initial filling of the boiler, the reset switch must be activated to initialize the safety lockout circuit. Once the water in the boiler has reached the proper level, the level control will stop the flow of water to the boiler. As water is consumed in the production of steam, the level control will replenish water to the boiler.

Firing Cycle

The gas valve is controlled by pressure sensing devices. On initial operation of the boiler, steam generation should reach 11 psi in approximately 15 minutes. At this point the "Operating Pressure" switch will close the gas valve. When pressure drops to 9 psi, the pressure switch opens the gas valve and ignition should occur.

Should the pressure rise to more than 14.5 psi the "Override pressure switch" will open the override solenoid valve, releasing the excess steam.

INSTALLATION AND OPERATION MANUAL, DIRECT STEAM KETTLES MOUNTED ON GAS
BOILER CABINET BASE, GMT-6, GMT-10, GMT-6-6, GMT-10-6, GMT-10-10

OPERATION INSTRUCTIONS (Continued)

Condensing Drain

A thermostat is located in the drain assembly and is activated by the temperature of steam. The thermostat opens the cooling solenoid valve, supplying water to the drain to condense the steam.

Automatic Blowdown Valve

If the unit has an automatic blowdown valve, it is activated by the main power switch. The boiler will drain should the main power switch be turned "OFF."

Safety Lockout Conditions

High Temperature Condition

A high temperature safety device is installed on the boiler. Should the temperature exceed the limit of this device, the boiler will be shut down and be put in a state of lockout. The "Temperature" pilot light (Red), and the "Standby" pilot (amber), will come on.

High Pressure Condition

A high pressure safety switch is installed on the boiler. Should the pressure exceed the limit of this device, the boiler will be shut down and be put into a state of lockout. The "Pressure" pilot light (Red), and the Stand By pilot (amber), will come on. Should this device fail to operate, the safety relief valve will open.

Low Water Condition

A second low water safety cut off is supplied with the boiler. Should the water level fall below normal operating levels, this device will activate and put the boiler in a state of lockout. The "Low Water" pilot light (Red), and the "Stand By" pilot (amber) will come on.

INSTALLATION AND OPERATION MANUAL, DIRECT STEAM KETTLES MOUNTED ON GAS
BOILER CABINET BASE, GMT-6, GMT-10, GMT-6-6, GMT-10-6, GMT-10-10

5.0 PERIODIC MAINTENANCE

Be sure to flush your boiler water level control daily. Failure to follow this procedure can cause the control to malfunction resulting in serious boiler damage.

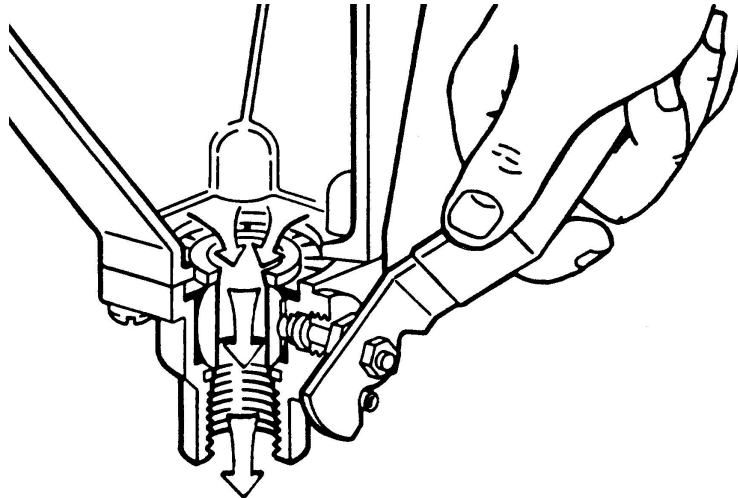

The Boiler Water Level Control installed on your boiler requires periodic maintenance. As boiler water circulates into the float chamber, sand, scale and other sediment may be deposited in the float chamber. While the chamber has been designed with a large accumulation bowl, it is necessary to flush the sediment from the chamber by blowing down the control so that the accumulation of sediment does not interfere with the movement of the float in the control. Control must be flushed at least once a day.



CAUTION: Protect yourself. When flushing control, hot water and steam will flow out of the drain.

When flushing control, note water level in gauge glass, allow the boiler to fill if necessary and also to come up to temperature.

Before flushing control, note that water level in gauge glass is within operating range and the boiler pressure is at least 6 psi. While the boiler is being fired, open blowdown valve at bottom of control by rotating the handle counterclockwise about 1/4 turn to fully open the valve. Opening the blowdown valve also checks the cut-off operation. Float should drop shutting burner off, hot water and steam will flow out the drain flushing away sediment.

INSTALLATION AND OPERATION MANUAL, DIRECT STEAM KETTLES MOUNTED ON GAS
BOILER CABINET BASE, GMT-6, GMT-10, GMT-6-6, GMT-10-6, GMT-10-10

5.0 PERIODIC MAINTENANCE (Continued)



CAUTION: If burner does not shut off during blowdown, immediately discontinue use of appliance and call for service.

Continue draining water for about fifteen (15) seconds, from control until water is clean. Manually close valve. Recheck gauge glass. If water level has dropped significantly, wait for the boiler to restore water level and pressure and repeat if necessary.

PERIODIC MAINTENANCE



WARNING: Disconnect the power supply to the appliance before cleaning or servicing.

1. If water in sight glass is not clear and appears murky, this indicates poor water quality and may cause control failure. SEE WATER QUALITY STATEMENT, page 4.
2. Safety valve should be tripped during operation once a week to ensure that it is functioning properly.
3. Clean around burners and orifices if lint has accumulated.
4. Visually ensure carry over ports are unobstructed.
5. Visually check that the flue is not obstructed.

CLEANING

DO NOT allow water near the electrical components.

At the end of the day, turn the Main Power Switch OFF (automatic blowdown drains the boiler tank) or if equipped with manual blowdown valve, open. Wash exterior with mild detergent and warm water, rinse, and wipe dry. Do not use steel wool on stainless steel surfaces.

INSTALLATION AND OPERATION MANUAL, DIRECT STEAM KETTLES MOUNTED ON GAS
BOILER CABINET BASE, GMT-6, GMT-10, GMT-6-6, GMT-10-6, GMT-10-10

MAINTENANCE

REMOVAL OF LIME SCALE DEPOSITS

The interior of the steam boiler should be inspected at least twice a year by your authorized servicer to determine whether the boiler needs to be delimed. The servicer should perform any necessary deliming procedure. See descaling instructions.

VENT HOOD

Twice a year check the venting system (hood); remove any obstructions; and clean as necessary.

BOILER DESCALING INSTRUCTIONS

It is recommended that the boiler be checked every 90 to 120 days for scale build up. Regular maintenance should be carried out at this time.

If the boiler is descaled, a new Anode should be installed in the boiler to help extend its life.

1. With boiler empty, close manual blowdown valve. If appliance is equipped with automatic blowdown, turn water supply OFF to appliance. Turn power switch ON. This will energize and close blowdown valve.
2. Remove 3/4" pipe plug from fitting on left front of boiler.
3. Insert appropriate hose or tube through fitting and pour in (1/2) half gallon (U.S.) of CLR Descaling solution.

Or use the Optional Deliming assembly DPA-1 available from your dealer. For appliances equipped with CSD-1, descaling solution must be introduced through hand hole.

4. Replace 3/4" pipe plug securely.
5. Open water supply to appliance allowing water to fill boiler to required level.

INSTALLATION AND OPERATION MANUAL, DIRECT STEAM KETTLES MOUNTED ON GAS
BOILER CABINET BASE, GMT-6, GMT-10, GMT-6-6, GMT-10-6, GMT-10-10

BOILER DESCALING INSTRUCTIONS (Continued)

6. Let appliance cycle, allowing two hours for descaling and cleaning. **DO NOT TURN STEAM ON TO CONNECTED APPLIANCES OR TO UPPER COMPARTMENTS.**
7. Open both the blowdown and low water level control valves for complete drainage. Then close both valves.

For appliances equipped with automatic blowdown, turn OFF power switch and open low water control valve. This will allow complete drainage. Once drained close water level control valve.

8. Turn appliance switch ON. When boiler is completely filled, turn power switch OFF. This will rinse and drain boiler. Appliance with manual blowdown valve must be opened to drain.
9. Complete Step 8 twice to assure boiler is completely rinsed.
10. Appliance is now ready for use.

6.0 ADJUSTMENTS

NOTICE: Contact the factory, the factory representative or local service company to perform maintenance and repairs.

TO CALIBRATE PRESSURE SWITCHES

NOTE: Pressure switches are factory set. Calibration is only required if pressure switches are replaced or if adjustment is required.

INSTALLATION AND OPERATION MANUAL, DIRECT STEAM KETTLES MOUNTED ON GAS
BOILER CABINET BASE, GMT-6, GMT-10, GMT-6-6, GMT-10-6, GMT-10-10

TO CALIBRATE PRESSURE SWITCHES (Continued)

Pressure switch range is from 1 to 15 psi.

Adjust all settings to maximum on high signal adjustment screw on pressure switches.

Adjust in the following sequence:

- High limit pressure switch.
- Override pressure switch.
- Operating pressure switch.
- Turning screw clockwise to increase, counterclockwise to decrease pressure.
- Use relief valve to release pressure from boiler for setting adjustments.

1. HIGH LIMIT PRESSURE SWITCHES

Allow pressure to build until unit shuts off. This should occur at 15 psi. Set the high signal to switch at 14.5 psi on the gauge and the low signal to 13.0 psi.

2. OVERRIDE PRESSURE SWITCHES

Allow pressure to increase to 13 psi. Set the high signal to switch at 13 psi on the gauge and the low signal to 11 psi.

3. OPERATING PRESSURE SWITCHES

Set the high signal to switch at 11 psi on the gauge and the low signal to 9 psi.

4. Release pressure in boiler to below 9 psi. Burner will come on. Once pressure has reached 11 psi, burners will shut off. Repeat this process several times to make sure burners come on at 9 psi and shut off at 11 psi.

Once completed, pressure switches have been calibrated.

Should your unit not have the High Limit pressure switch, start procedure at Override pressure switch.

SERVICE

Contact your local authorized service office for any repairs or adjustments needed on this equipment.

INSTALLATION AND OPERATION MANUAL, DIRECT STEAM KETTLES MOUNTED ON GAS
BOILER CABINET BASE, GMT-6, GMT-10, GMT-6-6, GMT-10-6, GMT-10-10

7.0 TROUBLESHOOTING



CAUTION: The appliance and its parts are hot. Use care when operating, cleaning and servicing the appliance.

BURNERS PRODUCE CARBON DEPOSITS

1. Wrong size orifices.
2. Burner air not adjusted properly.
3. Wrong gas supply.
4. Incorrect pressure at supply.

PILOT DOES NOT LIGHT OR GOES OUT

1. Gas not on.
2. Power supply is off.
3. Gas control knob is off.
4. Low incoming gas pressure.
5. Check thermocouple millivolts.
6. Dirty or loose wire connection to ignition module. Clean and/or tighten.
7. Pilot outage due to draft, excess steam from drain or unit not level. Improper venting can direct the flame away from the thermocouple or flame sensor.
8. Ignitor cable shorting out. Check that it is not contacting with metal or isn't damaged. May require replacement.
9. Ignition module not receiving power. Check output voltage from transformer is 24 volts.

INSTALLATION AND OPERATION MANUAL, DIRECT STEAM KETTLES MOUNTED ON GAS
BOILER CABINET BASE, GMT-6, GMT-10, GMT-6-6, GMT-10-6, GMT-10-10

7.0 TROUBLESHOOTING (Continued)

10. Unit in 100% lock out. Turn off and try again in five minutes.
11. Cracked ceramic insulator on pilot/ignitor sensor. Replace.
12. No spark, ignition module malfunction. Replace.
13. Pilot not adjusted correctly.

BURNER DOES NOT COME ON

1. Gas supply to unit is "OFF".
2. Manual shut off valve is "OFF".
3. Power supply is "OFF".
4. Faulty valve or ignition module.
5. Pilot out.
6. Pilot may require flame adjustment.
7. Water level has not been reached in boiler. Check water supply is on, check water level control.
8. If water at proper level, check relay which energizes pressure switch and gas control.
9. Pressure switch may need to be replaced if relay is operating.
10. Gas control may also require replacement if energized but not operating.
11. High Limit Thermostat open.

SAFETY RELIEF VALVE BLOWS

1. Defective valve.
2. Pressure too high, pressure switch requires adjustment (lower) or may be defective.

INSTALLATION AND OPERATION MANUAL, DIRECT STEAM KETTLES MOUNTED ON GAS
BOILER CABINET BASE, GMT-6, GMT-10, GMT-6-6, GMT-10-6, GMT-10-10

WATER NOT BEING SUPPLIED TO BOILER

1. Water supply is "OFF".
2. Defective water fill Solenoid Valve.
3. Water level control clogged or defective, unable to operate fill valve.
4. Check that drain valve is closed.
5. Supply water pressure too low.

BOILER SLOW TO HEAT UP

1. Lime build up - contact service.

8.0 INTRODUCTION - DIRECT STEAM KETTLES

FUNCTIONING MODE

Direct connected steam jacketed kettles consist of a stainless steel bowl and a stainless steel jacket which envelopes two thirds of the lower surface of the bowl thus forming a sealed pressure vessel (chamber) into which steam is introduced by means of a manual control valve.

The kettle bowl is the container for the food product which ideally should be of a liquid or semi-liquid consistency to achieve complete contact with the bowl surface and thus fully absorb the heat transmitted through that surface.

The temperatures required for the cooking process to function adequately must be greater than the boiling point of the liquid food product. Further, the greater the steam pressure used, the higher the temperature and consequently the quicker the cooking process. For example, steam pressurized at 30 psi attains a temperature of 274 degrees Fahrenheit (135 degrees Celsius).

In the initial stages of the cooking process when the steam comes in contact with the cold kettle bowl surface it condenses and forms considerable amounts of water. A thermostatic steam trap has been plumbed to the exit end of the kettle jacket. This trap is a mechanical device that closes on high temperatures and opens when the temperature drops thus allowing the water formed from condensate to exhaust but retain steam under pressure.

INSTALLATION AND OPERATION MANUAL, DIRECT STEAM KETTLES MOUNTED ON GAS
BOILER CABINET BASE, GMT-6, GMT-10, GMT-6-6, GMT-10-6, GMT-10-10

9.0 OPERATING PROCEDURES



CAUTION: The appliance and its parts are hot. Use care when operating, cleaning and servicing the appliance.

WITH BOILER IN OPERATION MODE

1. Fill kettle with product to desired level.
2. Slowly turn the steam control valve ON to full open position.
3. The water or food should boil 3 - 4 minutes per gallon. If it does not, then incoming pressure should be checked to determine that it is adequate to operate the kettle efficiently.
4. Regulate steam control valve depending on type of food being prepared.
5. When food is cooked, turn off steam, remove food and clean kettle immediately to prevent residue from drying on kettle bowl surface.

INSTALLATION AND OPERATION MANUAL, DIRECT STEAM KETTLES MOUNTED ON GAS
BOILER CABINET BASE, GMT-6, GMT-10, GMT-6-6, GMT-10-6, GMT-10-10

10.0 CLEANING PROCEDURES



CAUTION: Do not use cleaning agents that are corrosive.

Your kettle should be cleaned immediately after each use.

1. Ensure that steam supply is OFF.
2. Pre-rinse inside of kettle thoroughly and tilt to remove any food particles.
3. Using a nylon brush, clean kettle with a mild detergent and warm water rinse. Never use steel wool or scouring powder as it will scratch stainless steel.
4. Tilt kettle and rinse thoroughly draining out detergent solution.

Use of cleaning agents that contain chloride, acids or salts are corrosive and may cause pitting and corrosion when used over a period of time; this will reduce the life of the appliances.

Should pitting or corrosion occur this is not covered by warranty.

Follow the recommended cleaning instructions. Use a mild detergent, warm water and rinse thoroughly.

WHAT TO DO IF SURFACE RUST APPEARS

Metal utensils should never be used as they will scratch the surface of the equipment and rust may begin to form. To remove surface accumulation of rust from the inadvertent use of such utensils, the following procedure may be used.



CAUTION: Improper use of this procedure may damage your appliance!

1. Use undiluted white vinegar with a non-abrasive scouring pad (plastic) or cloth on the affected area to remove the rust stain. The appliance should not be heated and remain at room temperature during the entire cleaning process.
2. If the stain resists removal, additional exposure time with vinegar may be required, to a maximum of one hour.
3. Thoroughly wash all of the vinegar away with fresh clear water. Dry the surface completely and allow one hour before using the appliance to cook.

Following daily and period maintenance procedures will prolong the life for your equipment. Climatic conditions - salt air - may require more thorough and frequent cleaning or the life of the equipment could be adversely affected.

11.0 PREVENTIVE MAINTENANCE

No preventive maintenance is required other than adhering to the Cleaning Procedure instructions.

NOTICE: Contact the factory, the factory representative or local service company to perform maintenance and repairs.