



IMPORTANT FOR FUTURE REFERENCE
Please complete this information and retain this manual for the life of the equipment:

Model #: _____
Serial #: _____
Date Purchased: _____

PARTS LIST

Electric Floor Model Braising Pan With Manual Gearbox Tilt

ES-30 ES-40

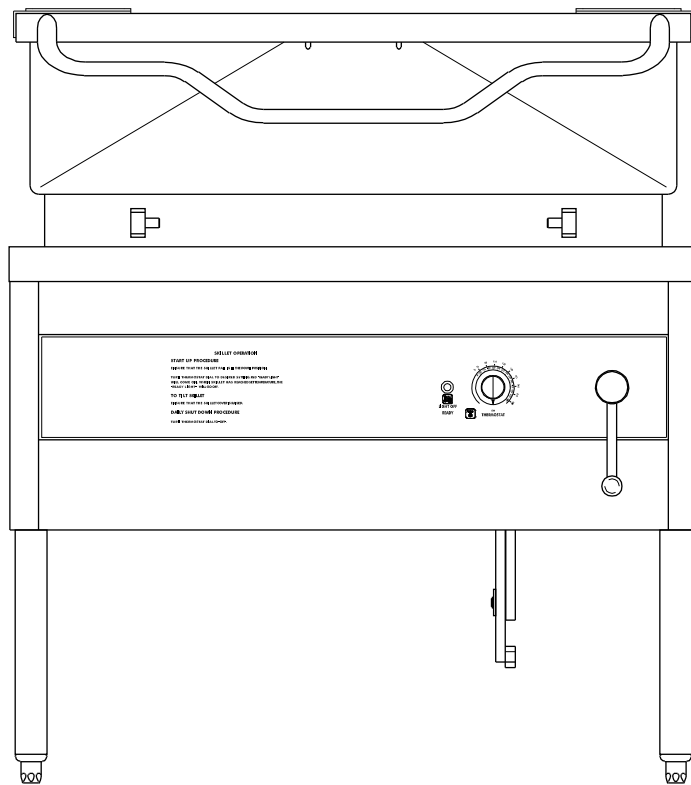

 **WARNING**

Improper installation, adjustment, alteration, service or maintenance can cause property damage, injury or death. Read the installation, operating and maintenance instructions thoroughly before installing or servicing this equipment.

CROWN FOOD SERVICE EQUIPMENT

 A Middleby Company

70 Oakdale Road, Downsview (Toronto) Ontario, Canada, M3N 1V9
Telephone: 919-762-1000 www.crownsteamgroup.com

Printed in Canada



PARTS LIST, ELECTRIC TILTING SKILLETS, MODELS: ES-30, ES-40

FIGURE 1

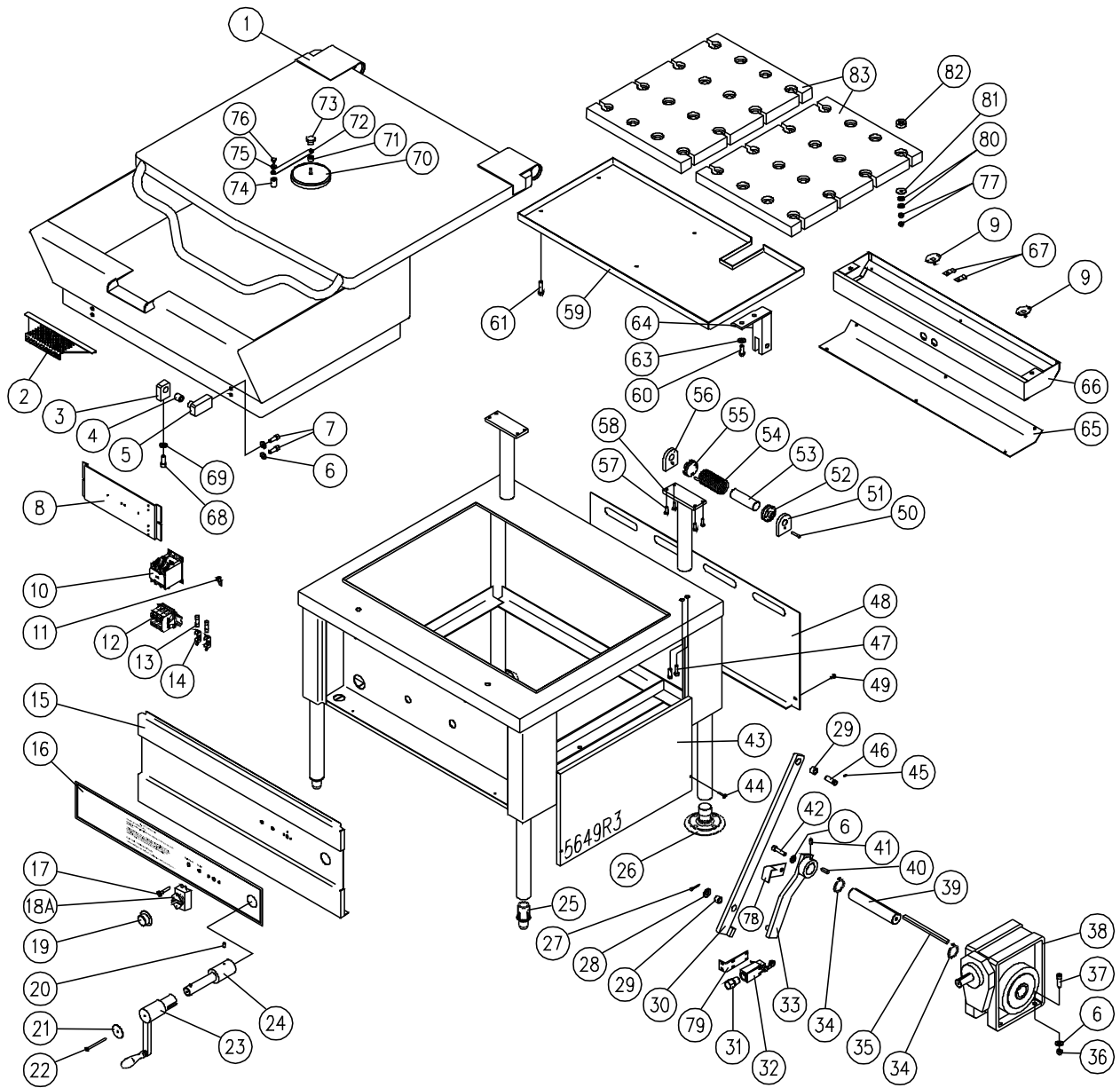

PARTS LIST, ELECTRIC TILTING SKILLETS, MODELS: ES-30, ES-40

FIGURE 1

<u>ITEM</u>	<u>PART NO.</u>	<u>DESCRIPTION</u>	<u>ES-30</u>	<u>ES-40</u>	
1	7386-2	Cover Assembly	1		
	7387-2	Cover Assembly		1	
2	7380-1	Pour Lip Strainer	1	1	
3	5877-1	Base Bracket	2	2	
4	3704-1	Bronze Bearing	2	2	
**	5	5878-1	Right Hand Pan Bracket Assembly	1	1
		5878-2	Left Hand Pan Bracket Assembly	1	1
6	S01X-38	Lock Washer	8	8	
7	M68P-3816-1	Socket Head Screw	4	4	
8	8068-1	Component Mounting Panel	1	1	
9	4874-1	High-Limit Thermostat	2	3	
**	10	4-CG42-1	Contactora, 208, 220, 240V	1	1
		9348-208	Contactora, 380/220V, 415/240V, 380, 415, 480, 600V	1	1
11	4-70EU	Ground Lug	1	1	
**	12	6161-4	Modular Terminal Assembly, 4 Pole (208 - 240V)	1	1
		Includes the following parts:			
		9374-1	Modular Terminal, Grey	4	4
		9375-1	End Plate	1	1
		9369-1	End Clamp	2	2
		9368-098	Mounting Rail, 98 mm	1	1
		6161-3	Modular Terminal Assembly, 3 Pole (380, 415, 480V)	1	1
		Includes the following parts:			
		9374-1	Modular Terminal, Grey	3	3

PARTS LIST, ELECTRIC TILTING SKILLETS, MODELS: ES-30, ES-40

<u>ITEM</u>	<u>PART NO.</u>	<u>DESCRIPTION</u>	<u>ES-30</u>	<u>ES-40</u>	
**	12	9375-1	End Plate	1	1
		9369-1	End Clamp	2	2
		9368-079	Mounting Rail, 79 mm	1	1
		6161-4N	Modular Terminal Assembly, 3 Pole with Neutral (380/220V - 415/240V)	1	1
		Includes the following parts:			
		9374-1	Modular Terminal, Grey	3	3
		9374-2	Modular Terminal, Blue	1	1
		9375-1	End Plate	1	1
		9369-1	End Clamp	2	2
		9368-098	Mounting Rail, 98 mm	1	1
**	13	9092-3	Fuse, 3 Amp., 250V (208, 220, 240V)	2	2
		9001-2	Fuse, 1/2A, 600V (380, 415, 480, 600V)	2	2
**	14	9068-1	Fuse Holder, (208, 220, 240V)	2	2
		9002-1	Fuse Holder, (380 415, 480, 600V)	2	2
	15	7432-1	Control Panel	1	
		7432-2	Control Panel		1
	16	7276-1	Control Panel Decal	1	
		7276-2	Control Panel Decal		1
	17	4661-4	Temperature Pilot - Red	1	1
	18A	4-TH47	Operating Thermostat	1	1
*	18B	5952-1	Clamp, Thermostat Bulb	1	1
**	19	4736-1	Dial (F)	1	1
		4737-1	Dial (C)	1	1
*		4-TB05	Bezel	1	1

PARTS LIST, ELECTRIC TILTING SKILLETS, MODELS: ES-30, ES-40

<u>ITEM</u>	<u>PART NO.</u>	<u>DESCRIPTION</u>	<u>ES-30</u>	<u>ES-40</u>
20	9061-4	Set Screw, 1/4 - 20 x 1/2	1	1
21	5608-1	Tilt Decal	1	1
22	M33S-1032-3	Screw, 10 - 32 x 3	1	1
23	5628-1	Tilt Handle Assembly	1	1
24	5627-1	Input Shaft	1	1
25	5-FS64-1	Adjustable Foot	2	2
26	8-1308	Flanged Adjustable Foot	2	2
27	5329-4	Cotter Pin, 1/8 x 1" Long	1	1
28	9397-6	Flat Washer, 1/2" x 1-1/4, OD x 0.078 Thick	1	1
29	9103-2	Bronze Bearing	2	2
30	5619-1	Upper Tilt Arm	1	1
31	9176-1	Liquid Tight Connector/Strain Relief	1	1
*	9176-2	Liquid Tight Locknut	1	1
32	9168-1	Tilt Switch	1	1
33	5620-1	Lower Tilt Arm	1	1
34	9174-1	Retaining Ring	2	2
35	5337-2	Key, 8 mm x 10 mm x 5.5"	1	1
36	9029-3	Hex Nut, 3/8 - 16	4	4
37	M68P-3816-114	Screw, 3/8 - 16 x 1-1/4"	4	4
38	9131-1	Gear Box	1	1
39	5637-1	Output Shaft	1	
	5637-2	Output Shaft		1
40	5337-3	Key, 8 mm x 10 mm x 1"	1	1
41	9061-5	Set Screw, 3/8 - 16 x 1/2"	1	1
42	M68P-3816-112	Screw, 3/8 - 16 x 1-1/2"	1	1

PARTS LIST, ELECTRIC TILTING SKILLETS, MODELS: ES-30, ES-40

<u>ITEM</u>	<u>PART NO.</u>	<u>DESCRIPTION</u>	<u>ES-30</u>	<u>ES-40</u>	
43	7448-1	Right Hand Access Panel	1	1	
44	M33S-1032-1	Screw 10 - 32 x 1	4	4	
45	9061-2	Set Screw, 8 - 32 x 5/16"	1	1	
46	5624-1	Yoke Pin	1	1	
47	M50S-51618-1	Screw, 5/16 - 18 x 1	4	4	
48	7449-1	Rear Panel	1		
	7462-1	Rear Panel		1	
49	M33S-1032-12	Screw, 10 - 32 x 1/2"	4	4	
50	8-2029	Lock Pin	2	2	
51	8-2035L	End Lock Plate	2	2	
52	5428-1	Stationary Disc	2	2	
53	5430-1	Core	2	2	
54	8-2026	Spring	2	2	
55	5429-1	Rotary Disc	2	2	
56	8-2021	End Stop Plate	2	2	
57	M50S-1420-34	Screw, 1/4 - 20 x 3/4"	8	8	
58	5651-1	Hinge Support Assembly	2	2	
59	8052-1	Element Cover	1		
	8053-1	Element Cover		1	
60	M50S-3816-1	Hex Hd. Screw, 3/8-16 UNC x 1" Lg.	2	2	
61	M50S-3816-112	Hex Hd, 3/8-16 UNC x 1-1/2 Lg.	4	4	
* **	62	4-T251	Transformer, 380/415V - 240V, 100VA [4298]	1	1
		4-T255	Transformer, 480-240V, 100 VA [9216]	1	1
		4-T260	Transformer, 600 - 240V	1	1

PARTS LIST, ELECTRIC TILTING SKILLETS, MODELS: ES-30, ES-40

<u>ITEM</u>	<u>PART NO.</u>	<u>DESCRIPTION</u>	<u>ES-30</u>	<u>ES-40</u>
63	S05N-38	Split Lock Washer, 3/8	2	2
64	8064-1	Yoke	1	1
65	8061-1	Terminal Enclosure Cover	1	
65	8061-2	Terminal Enclosure Cover		1
66	8054-1	Terminal Enclosure Box	1	
	8054-2	Terminal Enclosure Box		1
67	3602-1	Clamp	2	2
68	M68P-1213-1	Socket Head Screw, 1/2-13 UNC x 1	2	2
69	S01X-12	Split Lock Washer, 1/2	2	2
70	4139-1	Vent Cover	1	1
71.	5837-1	Swivel Spacer	1	1
72	5817-1	Arm	1	1
73	9248-1	Knob	1	1
74	5836-1	Swivel Base	1	1
75	F05N-14	Washer, 1/4, Stainless Steel	1	1
76	9031-5	Acorn Nut, 1/4 - 20 UNC	1	1
77	1-69C0	Hex Nut, 5/16 - 18 UNC	64	80
78.	5767-1	Tilt Switch Cam	1	1
79	5635-1	Tilt Switch Bracket	1	1
80	9078-1	Flat Washer, 11/32 ID x 1-1/2 OD x 0.083 Thk.	32	40
81	9063-1	Disc Springs	64	80
82	3599-1	Element Block Spacer	32	40
* **	83	7545-208	Element Assembly, 208V, 6 kW	2
		7545-220	Element Assembly, 220/380, 6 kW	2
		7545-240	Element Assembly, 240/415V, 6 kW	2

PARTS LIST, ELECTRIC TILTING SKILLETS, MODELS: ES-30, ES-40

<u>ITEM</u>	<u>PART NO.</u>	<u>DESCRIPTION</u>	<u>ES-30</u>	<u>ES-40</u>
	7545-277	Element Assembly, 480 (277V), 6 kW	2	
	7547-208	Element Assembly, 208V, 6 kW		3
	7547-220	Element Assembly, 220/380, 6 kW		3
83	7547-240	Element Assembly, 240/415V, 6 kW		3
	7547-277	Element Assembly, 480 (277V), 6 kW		3

* NOT SHOWN.

** SELECT AS REQUIRED.