

Compact by Naboo Compact by Sapiens

Gas-Fired or Electric Combi Oven/Steamer



OWNER'S MANUAL



FOR YOUR SAFETY
Do not store or use gasoline or other flammable vapors or liquids in the vicinity of this or any other appliance.

GAS LEAK INSTRUCTIONS
Post in a prominent location, instructions to be followed in the event of user smelling gas. This information shall be obtained by consulting the local gas supplier.

WARNING
Improper installation, adjustment, alteration service or maintenance can cause property damage, injury or death. Read the installation, operating and maintenance instructions thoroughly before installing or servicing this equipment.

FOR SAFE AND EFFICIENT OPERATION OF THIS EQUIPMENT, THIS MANUAL MUST BE RETAINED BY THE OWNER/USER FOR FUTURE REFERENCE.

WARNINGS

WARNING
DEATH, INJURY, AND EQUIPMENT DAMAGE could result from improper installation of the Oven/Steamer, or from installation of a unit damaged during shipment or storage. Either of these conditions could also void the equipment warranty. **DO NOT INSTALL** a Oven/Steamer suspected of damage. Install the Oven/Steamer according to the policies and procedures outlined in this manual.

WARNING
NEVER EXCEED 14"/355.6 mm WATER COLUMN (1/2 psi) GAS PRESSURE. If the gas supply pressure exceeds 14"/355.6 mm water column, a pressure regulating valve must be installed in the gas supply plumbing to reduce the gas pressure to less than 14"/355.6 mm water column.

WARNING
Using water not within the limits specified in this manual could void or adversely affect the warranty coverage of the Oven/Steamer.

WARNING
The flooring directly under this unit must be made of non-combustible material.

WARNING
CAUTION - To reduce the risk of the fire, the appliance is to be installed in non-combustible surroundings only, with no combustibile material within 18 inches of the sides, front, or rear of the appliance or within 40 inches above the appliance. The appliance is to be mounted on floors of noncombustibile construction with noncombustibile flooring and surface finish and with no combustibile material against the underside, or on no combustibile material against the undrside. Such construction shall in all cases extend not less than 12 inches beyond the equipment on all sides.

WARNINGS

WARNING

All clearance requirements above, below, and around the unit are the same for combustible or non-combustible locations.

Maintain at least 20"/500 mm clearance on the right of the unit.

Maintain at least 10"/254 mm clearance at the rear of the unit.

Maintain at least 40"/1000 mm clearance above the unit.

WARNING

Malfunctions and equipment damage may result from improper mounting.

Malfunctions and/or damage resulting from improper mounting are not covered by the equipment warranty. The Oven/Steamer **MUST BE LEVEL BOTH FRONT TO BACK AND SIDE TO SIDE** in all mounting arrangements.

Equipment damage may result from shifting the Oven/Steamer more than 3° out of level while power is turned on.

WARNING

INJURY AND EQUIPMENT DAMAGE could result from improper lifting. Refer to the appropriate dimension and check the weight of the unit being installed.

Use enough workers with experience of lifting heavy equipment to place the Oven/Steamer on the supporting surface.

WARNING

DEATH, INJURY, AND EQUIPMENT DAMAGE could result from improper installation of the drain outlet lines.

Improper installation of these lines could void the Oven/Steamer warranty. The following restrictions are critical to the safety of personnel and equipment, and must not be violated under any circumstances.

Do not connect the drain line into PVC pipe, or any other drain material that cannot sustain 180 °F/82 °C.

Do not connect drains from any other equipment to the Oven/Steamer drain line.

Do not connect the drain outlet extension line directly to a floor drain or sewer line.

Do not block drain vents at the top of the unit ( ).

WARNINGS

WARNING

**DO NOT TRY TO LIGHT THE BURNERS OR PILOT WITH A FLAME.
THERE IS NO PILOT TO LIGHT OR ADJUST.**

Ovens/Steamers have electronic ignition systems which automatically light the burners, sense the flame, and control gas flow. This provides both precise burner control and safety ignition and shutdown features.

DEATH, INJURY OR EQUIPMENT DAMAGE may result from an improperly adjusted gas control and ignition system. Do not alter any adjustments on this electronic control or solenoid valve. If adjustment is required, contact an authorized service center. The Manufacturer is in no way responsible for the operation or safety of this equipment if the controller, valve, or igniter probe are adjusted by anyone other than a authorized service representative.

WARNING

Equipment damage and faulty operation will result if the gas, water, or electrical supplies fall below requirements. This may be caused by other equipment on the same supply lines. During all tests, adjustments, and inspection of the Oven/Steamer, turn on all equipment drawing on the same supply lines.

WARNING

DO NOT ATTEMPT TO START OR OPERATE a Oven/Steamer during a power outage. Critical safety circuits are not energized, and serious injury to personnel or damage to equipment may result.

DEATH, INJURY, AND EQUIPMENT DAMAGE could result from improper operation of the Oven/Steamer.

Be sure oven/steamer has been installed correctly according to the installation instructions in Chapter 2 before starting operation.

WARNINGS

WARNING

For these appliances, the state of the metal components in direct contact with the source of heat must be checked. It is therefore advisable to make an annual visual check on the combustion chamber.

This precaution is sufficient to prevent any irreparable damage to the appliance.

WARNING

Steam leaks around the door, cooking compartment flooding, reduced cooking performance, and compartment implosion can be caused by a blocked drain or drain screen. Inspect and clean the drain and drain screen before each use.

Never operate the steamer without the screen in place.

WARNING

Do not use flammable cleaning agents to clean the Oven/Steamer, or in the vicinity of this appliance.

WARNING

Avoid any operation which leads to cooking salt being deposited on the steel surfaces of the oven. Should this happen, clean thoroughly and immediately.

WARNING

Before using your new appliance clean out the oven carefully. Do not use acids or corrosive cleaners, wire wool or brushes to clean either the oven cavity or the appliance cabinet (use warm water with a suitable detergent).

WARNING

Inside of oven/steamer stays hot for a long time. Be careful when cleaning inside oven/steamer compartment.

WARNING

Oven cleaners are caustic and if wrongly used can irritate the skin and eyes. Always follow the Manufacturer's instructions to the letter.

WARNINGS

WARNING

Let rinse water drain through compartment drain opening. If water does not drain freely, drain lines must be cleaned before cooking again. Clogged or slow drains are dangerous because hot water can collect in compartment and spill out when opening compartment door.

WARNING

DEATH, INJURY, OR EQUIPMENT DAMAGE may result from improper service or maintenance practices. Always turn the main power switch to **OFF** for any unit before starting service, maintenance or repairs.

WARNING

Steam leaks around the door, cooking compartment flooding, reduce cooking performance, and compartment implosion can be caused by a blocked compartment vent, or a blocked drain or drain screen. Inspect and clean the compartment vent, drain and drain screen before each use.

Never operate the oven/steamer without the screen in place.

WARNING

The liquid phosphoric acid in descaling can be harmful if not handled properly.

Follow these basic safety rules for handling and using acid.

Wear protective clothing when mixing or applying chemical cleaners. Wear rubber gloves, mask and approved cup-type goggles.

Avoid breathing fumes. If liquid comes in contact with skin, flush immediately with large quantities of cold water. Remove contaminated clothing.

If chemical contacts eyes, flush with cold water for a minimum of 15 minutes.

Get immediate medical attention.

If chemical is swallowed or ingested, follow instructions on the chemical container.

Get immediate medical attention.

WARNING

DEATH, INJURY, OR ELECTRIC SHOCK can occur by touching electrical components and wires inside the access panel when the main power switch is in the **ON** position. **NEVER REMOVE THE SERVICE ACCESS PANEL.**

Allow only Authorized Service Representatives to perform service, maintenance, and repairs that require the removal of the service access panel(s).

WARNINGS

WARNING

DEATH, INJURY, OR ELECTRIC SHOCK can occur by touching electrical, components and wires inside the access panel when the main power switch is in the **ON** position. **NEVER REMOVE THE SERVICE ACCESS PANEL.**
Allow only Authorized Service Representatives to perform service, maintenance, and repairs that require the removal of the service access.

WARNING

This appliance has more than one power supply connection point. Disconnect the power supply before replacing fuses.
ONLY FOR DOUBLE STACK VERSION

WARNING

WHEN APPLIANCE IS PROVIDED WITH CASTERS
-RISK OF ELECTRIC SHOCK-
APPLIANCE MUST BE SECURED TO BUILDING STRUCTURE.
SEE INSTALLATION INSTRUCTION

NOTICE

When this appliance is installed with casters, it must be installed with the casters supplied, a connector complying with either ansi z21.69-csa 6.16 and a quick-disconnect device complying with ansi z21.41-csa 6.9.
it must also be installed with restraining means to guard against transmission of strain to the connector, as specified in the appliance manufacturer's instruction.
The casters with brake must be on the front of the appliance

PROTECTING WARRANTY COVERAGE

The warranty printed to the left specifies the owner/user's responsibility for proper installation, operation and maintenance of the Combi Unit.

If these responsibilities are not met, the Limited Warranty and/or Extended Limited Warranty coverage may be adversely affected.

The following table is provided to assist the owner/user in meeting these responsibilities. In addition, the warranty advantages of installing a Steamer Gard water treatment system are explained after the table.

The Warranty Protection Table lists installation, operation, and maintenance factors that have in the past adversely affected warranty coverage.

The owner/user of a Combi Unit should pay particular attention to these factors to protect his warranty coverage.

This table is not a comprehensive list of the owner/user's responsibilities.

The Steamer are intended for use only by professionally trained personnel.

To meet his responsibilities, the owner/user must supplement this guide with any additional actions consistent with the operation of steam generating food preparation equipment by a trained professional.

TABLE OF CONTENTS

Chapter	Page
CHAPTER 1. PRODUCT IDENTIFICATION	12
MODEL NUMBER	12
PRODUCT TAGS	12
IDENTIFICATION PLATE	12
OVEN MODELS AND VERSION	13
TECHNICAL DATA	14
CHAPTER 2. INSTALLATION INSTRUCTIONS	15
INTRODUCTION	15
INSTALLATION POLICIES	15
INSTALLATION OVERVIEW	16
INSTALLATION DIAGRAM NOTES	19
INSTALLATION DIAGRAMS	20
PREPARATION FOR INSTALLATION	33
Unpacking and Inspection	33
Shipping Damage Instructions	33
Protecting The Oven / Steamer	33
Electric Power Requirements	34
Gas Supply Requirements	34
Water Quality Requirements	34
Softened, Treated, or Filtered Water	35
Water Supply System	36
Selecting The Operating Location	36
INSTALLATION INSTRUCTIONS	38
Position and Level the Oven/Steamer	38
Leg Mounting and Leveling	39
Assembly	39
Positioning and Leveling	40
Appliance equipped with casters	41
Install and Connect the Free Air Vented Drain Lines	42
Exhaust Port Ventilation	45
Install Electric Power Line	46
Connect Electrical Line	47
Install and Connect Water Supply Lines	48
Testing Water Supply Lines	50
Install and Connet Gas Supply Lines	50
Testing Gas Supply Lines and Burner Controls	51
Pressure Testing The Gas Supply Lines	51
Testing the Automatic Gas Valve and Burner Control System	52
Start-Up Check List	54
Initial Operation and Cleaning	56
Lighting Instructions	57
Shutdown Instructions	57

TABLE OF CONTENTS

CHAPTER 3. PREVENTIVE MAINTENANCE AND TROUBLESHOOTING	58
INTRODUCTION	58
MAINTENANCE RECORDS	58
DAILY MAINTENANCE	59
Blowdown Steam Generator	59
Cleaning	59
Inspect the Cooking Compartment Vent	59
WEEKLY MAINTENANCE	59
Clean Drain	59
Descale Steam Generator	60
Health Hazard Data, effects of Overexposure	60
Emergences and First aid Procedures	60
Troubleshooting notes	63

CHAPTER 1. PRODUCT IDENTIFICATION

a model number and a serial number. The model number identifies the product characteristics. The serial number identifies the individual unit (Figure 1-1).

MODEL NUMBER

This manual covers all models (for capacity in units): each model electric or gas-fired with or without steam generators.

Each character of a model number identifies a characteristic of the oven/steamer. The model number begins with **CBE..** (with steam generator, “E” means electric) or **CVG.. / CVE..** or **COE..** (without steam generator, “E” or “G” means electric or gas-fired), followed by a number for capacity in units. This manual covers all standard features and options available on the Oven/Steamer models listed above.

Other than selection of options, there are presently no significant design, parts, or operating differences among oven/steamers with the same model number. Figures 1-2 illustrate the models and identify the major components.

PRODUCT TAGS

Before shipping, each single unit is furnished with different tags which give you information on appliance operation. These tags are located on the lower right side of the unit close to the identification plate.

IDENTIFICATION PLATE

Figure 1-1 illustrates typical Identification Plates.

The plate is located on the right side of each unit as illustrated in Figures 2-1.

The Identification Plate lists the model number, gas supply requirement, power requirements, and wiring requirements of each Oven/Steamer.

The figure shows two identical identification plates side-by-side. Each plate contains the following information:

- ETL Certification:** Two circular logos at the top, one labeled 'LISTED' and the other 'IDENTIFICATION LISTED'.
- Manufacturer Info:** 'Intertek 3076890' on both sides, 'INTENDED FOR OTHER THAN HOUSEHOLD USE / DESTINE A UN USAGE AUTRE QUE DOMESTIQUE', and 'LAINOX ALI S.p.A., Vittorio Veneto, Treviso, Italy Made in Italy'.
- Standards:** 'ANSI Z83.11a - CSA 1.8a - 2006 Food Service Equipment CONFORMS TO ANSI/NSF 4'.
- Model and Serial:** 'MODEL / MODÈLE' and 's/n' with empty boxes for entry.
- Electrical Specs:** 'VOLT', 'HZ', 'PHASE', and 'AMPS' with empty boxes.
- Safety Warnings:** 'FOR USE ONLY ON NONCOMBUSTIBLE FLOORS / MINIMUM CLEARANCE FROM COMBUSTIBLE AND NONCOMBUSTIBLE CONSTRUCTION' and its French equivalent.
- Dimensions:** 'SIDES / CÔTES' (INCHES / POUÇES) and 'BACK / ARRIÈRE' (INCHES / POUÇES) with empty boxes.
- Warning:** 'WARNING APPLIANCES ADJUSTED FOR USE WITH ATTENTION APPAREIL PREDISPOSE POUR L'UTILISATION' with an empty box.
- Pressure/Power:** 'PRESSURE / PRESSION', 'I.V.C.', 'INPUT / PUISSANCE', and 'BTU/HR' with empty boxes.
- Additional Specs (Right Plate):** 'MAX LOAD AMPS' and 'CURRENT-CARRYING POWER SUPPLY CONDUCTORS' with empty boxes.

Figure 1-1. Identification Plate

OVEN MODELS AND VERSIONS

MODELS

CVGN 061 gas rating power BTU **29.000** (8,5 kW)
 CVGS 061

COMPARTMENT CAPACITY

6 trays 12"x20"x2 1/2" max. recommended load **53 lbs.** of food

MODELS

CVEN061 /CBEN061 rating power kW 8,25
 CVEN061 /CBEN061

COEN026 rating power kW 5,25
 COES026

COEN061 rating power kW 7,75
 COES061

COEN101 rating power kW 15,5
 COES101

COMPARTMENT CAPACITY

6 trays 12"x20"x2 1/2" max. recommended load **53 lbs.** of food

6 trays 12"x14"x2 1/2" max. recommended load **36 lbs.** of food

6 trays 12"x20"x2 1/2" max. recommended load **53 lbs.** of food

10 trays 12"x20"x2 1/2" max. recommended load **88 lbs.** of food

TECHNICAL DATA

Model	Nominal Rating BTU/kW	Consumption Amps	Water Pressure kPa/Psi	Consumption softened water max. Liter/hr
CVGN061 / CVGS061	BTU 29.000 - kW 8	4	200 500 kPa 35 60 Psi	8

Model	Power Rating kW	Voltage V	Max load Amps	Consumption softened water max. Liter/hr
CVEN061 / CVES061 CBEN061 / CBES061	8,25	AC 208V 3 AC 208V 3 AC 480V	40 30 13	8 8 8
COEN026 / COES026	5,25	AC 208V 3 AC 208V 3 AC 480V	25 16 7	8 8 8
COEN061 / COES061	7,75	AC 208V 3 AC 208V 3 AC 480V	37 23 10	8 8 8
COEN101 / COES101	15,5	3 AC 208V 3 AC 480V	46 20	8 8

* Connecting wires type: use copper wires only.

CHAPTER 2. INSTALLATION INSTRUCTIONS

This manual and several components are packaged inside the during shipment. To access these packages, the shipping crate has been disassembled. Discard the shipping crate and protect the from dirt and damage during storage, site preparation, and installation as described in “Protecting The Oven/Steamer.

WARNING

DEATH, INJURY, AND EQUIPMENT DAMAGE could result from improper installation of the Oven/Steamer, or from installation of a unit damaged during shipment or storage. Either of these conditions could also void the equipment warranty.

DO NOT INSTALL a Oven/Steamer suspected of damage.

Install the Oven/Steamer according to the policies and procedures outlined in this manual.

INTRODUCTION

This chapter is a guide for installation of the Oven/Steamer models identified in Chapter 1. This guide is for use by qualified professionals, and does not include all procedures and precautions in the common domain of licensed plumbers, pipe fitters, and electricians, or experienced food service equipment installers.

This guide must be used in conjunction with professional experience and a thorough understanding of the local and national utility, construction and sanitation codes; the most prominent of which are listed in the Installation Policies section below.

Before starting installation, the owner and the installer should read through this chapter and thoroughly understand and agree upon:

- The installation policies of The Manufacturer as stated in Installation Policies.
- An installation plan based on the Installation Overview and Installation Check List.
- Responsibility for feed water quality and its testing as described in Preparation For Installation, Water Quality Requirements.

INSTALLATION POLICIES

- The Oven/Steamer must be installed by qualified plumbing and electrical personnel, working to all applicable national and local codes. Equipment installation must comply with the Basic Plumbing Code of the Building Officials and Code Administrators International, Inc. (BOCA), the National Fuel Gas Code, ANSI Z223.1-(latest edition) or the Natural Gas Installation Code CAN/CGA-B149.1 or the propane Installation Code CAN/CGA-B149.2, the National Electric Code, ANSI/NFPA No. 70-(latest edition) or the Canadian electrical code, CSA 22.1, and the Food Service Sanitation Manual of the Food and Drug Administration (FDA).

CHAPTER 2. INSTALLATION INSTRUCTIONS

- All models of the Oven/steamers comply with the applicable standards for manufacturers. Included among those certification agencies are: etl and NSF.
- The Oven/Steamers are certified for safe operation only when permanently installed in accordance with local and/or national codes.
Many local codes exist, and it is the responsibility of the owner and installer to comply with these codes.
- In no event shall the Manufacturer assume any liability for damage or injury resulting from installations which are not in strict compliance with the Installation Instructions and the codes cited above. Specifically, The Manufacturer will not assume any liability for damage or injury resulting from improper installation of equipment, including, but not limited to, temporary or mobile installations.

INSTALLATION OVERVIEW

Installation of the Oven/Steamer is presented in two parts: preparation and installation. The Installation Check List, Table 2-1, lists the major tasks to be performed in a recommended sequence. Each item references the instructions for starting the task. Complete the preparation tasks in sequence, and then the installation tasks. Installation requirements may vary from site to site; adapt the check list accordingly. Schematic Installation Diagram, Figure 2.1, illustrates the utility lines and connections required to install the Oven/Steamer. The Dimension Drawings, Fig. 2-2, show the required utility connection points, dimensions, and clearances for each model.

TABLE 2-1. INSTALLATION CHECK LIST

TASK	PAGE REFERENCE
PREPARATION	
Unpack, inspect, and protect the unit.	33
Check electric power requirements.	34
Check gas power requirements.	34
Test supply water quality.	34
Select water treatment system.	36
Select operating location.	36
INSTALLATION	
Position and level steamer.	38
Assemble packaged components.	38
Install and connect drain line.	43
Connect exhaust flue diverter.	44
Install and connect electrical line.	47
Install and connect water supply lines.	49
Test water supply lines.	50
Install and connect gas supply lines	50
Test gas supply lines.	51
Perform start-up checks.	55

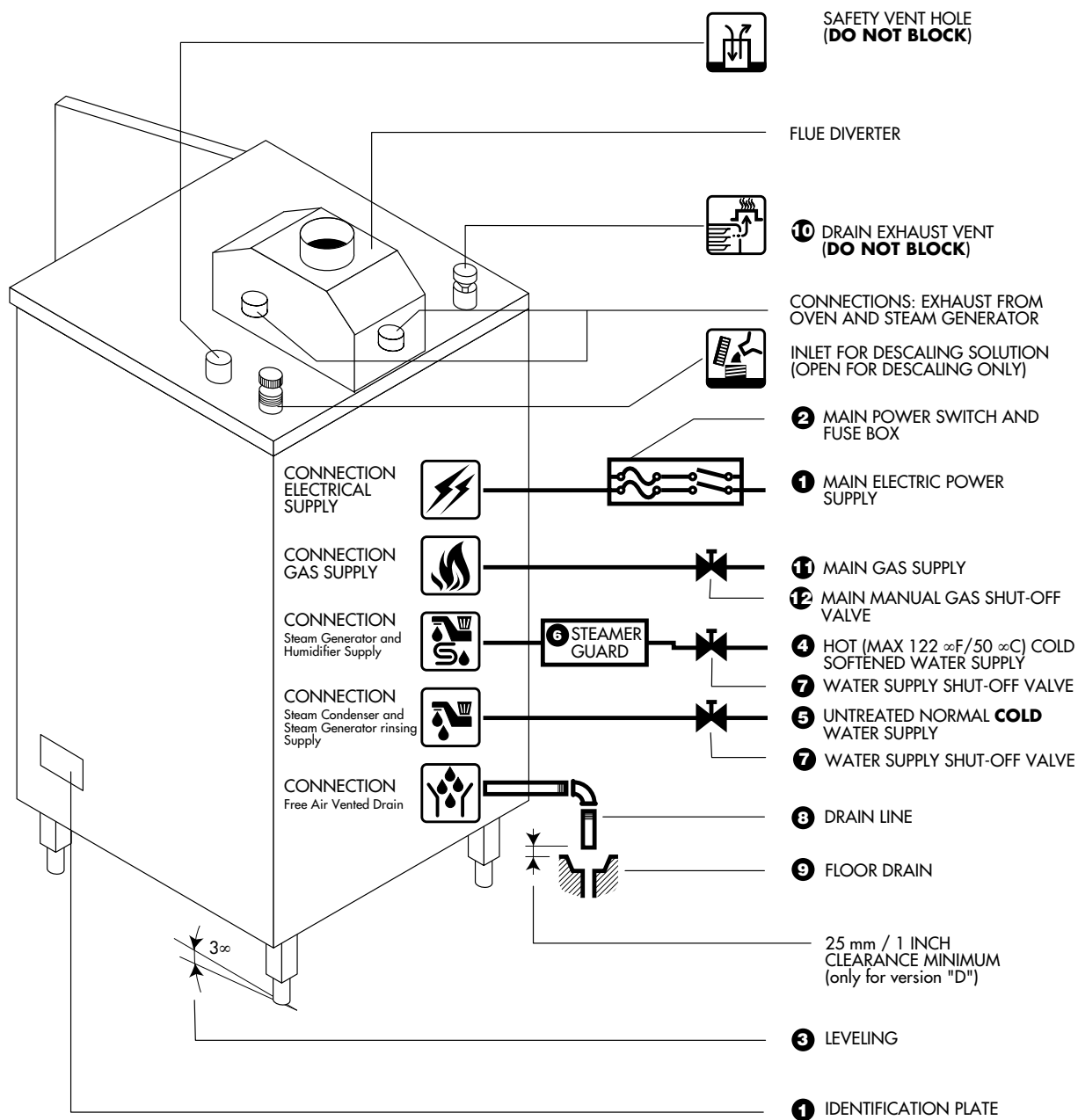





Figure 2-1

INSTALLATION DIAGRAM NOTES

- 1- The Product Identification Plate located on the right side service panel specifies the electric power requirements.
- 2- For each unit, the installer must provide a ground connection and a separate fused disconnect switch.
- 3- Catastrophic damage will result from shifting the more than 3° out of level while power is turned on at the unit's main power switch.
- 4- The unit must have an untreated cold water  supply NOT HOT, and a HOT (max. 122 °F/50 °C) cold softened water  supply.
- 5- The softened water supply must meet the quality requirements of Table 2-2, and the pressure requirements on installation diagrams (Fig. 2-2).
- 6- A Steamer Gard system is recommended when water quality does not meet the Table 2-2 requirements.
- 7- A manual water shut-off valve must be installed between the main softened water supply and the steamer supply line. Refer to Figures 2-8 and 2-9 for recommended component arrangements. A manual water shut-off valve must be installed between the main untreated main water supply and the steam condenser supply line.
- 8- The drain line: use a heat-resistant plastic pipe (not flexible), installed without loops or kinks and no longer than 2 meters with a slope of no less than 4 degrees, or realize a drain line with a gravity flow away from the Oven. Drain line must not be connected to the drain lines of any other equipment. In compliance with current standards, the drainage piping must not be connected in a straight line.
- 9- It is advisable to interpose a funnel (see drawing) to facilitate flow. **DO NOT REDUCE THE DRAIN LINE DIAMETER. DO NOT INSTALL A TRAP ON THE DRAIN LINE.**
- 10- Never block the drain exhaust  vent  and at the top of the Oven.

WARNING

NEVER EXCEED 14"/355.6 mm WATER COLUMN (1/2 psi) GAS PRESSURE.
If the gas supply pressure exceeds 14"/355.6 mm water column, a pressure regulating valve must be installed in the gas supply plumbing to reduce the gas pressure to less than 14"/355.6 mm water column.

- 11- A main manual gas shut-off valve must be installed between the main gas supply and the Oven/Steamer gas supply line.
- 12- Refer to figures 2-1 for the recommended component arrangements.



INSTALLATION DIAGRAMS

CVGN061 / CVGS061 / inch

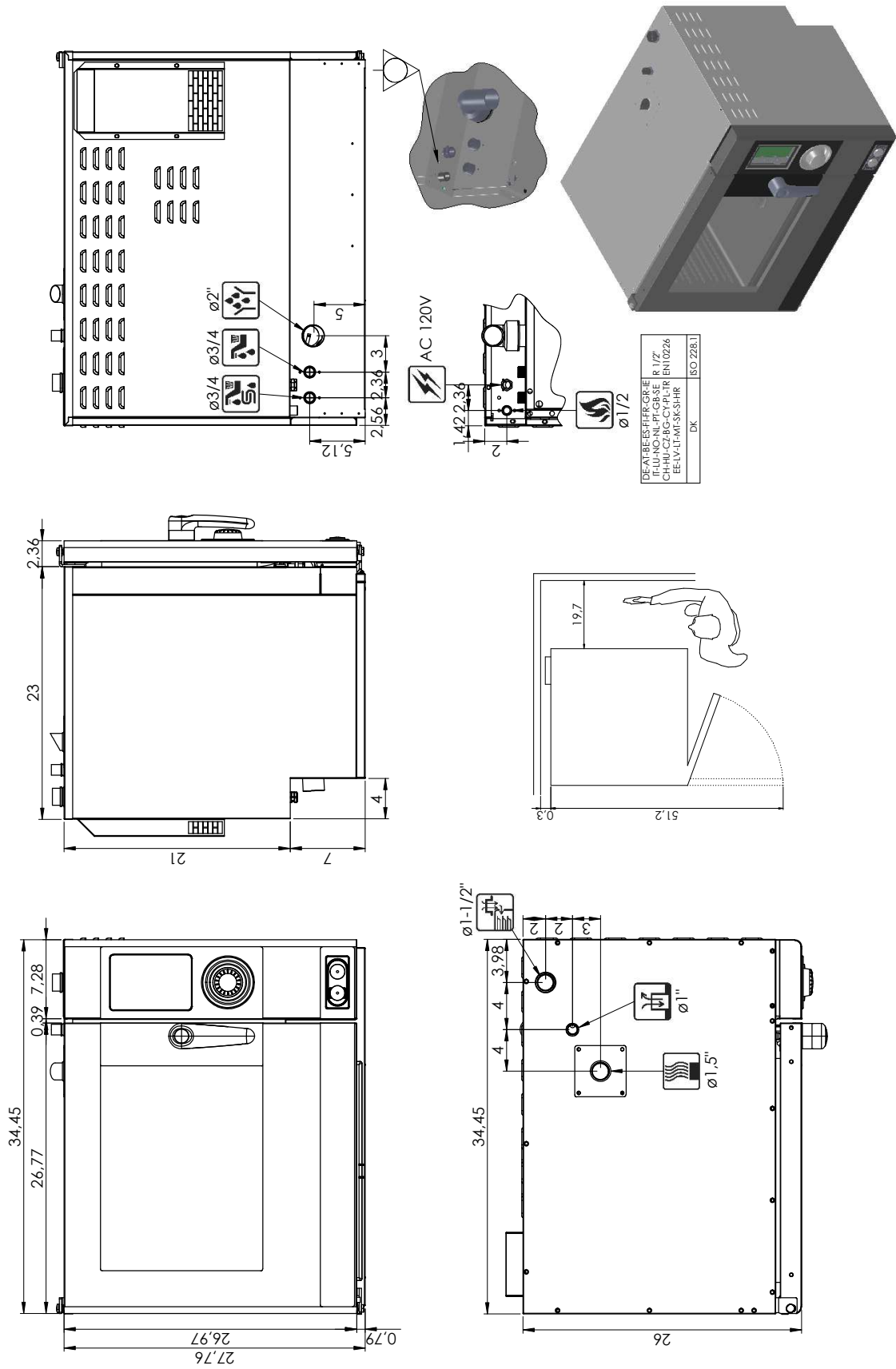

CVGN061 / CVGS061 / mm

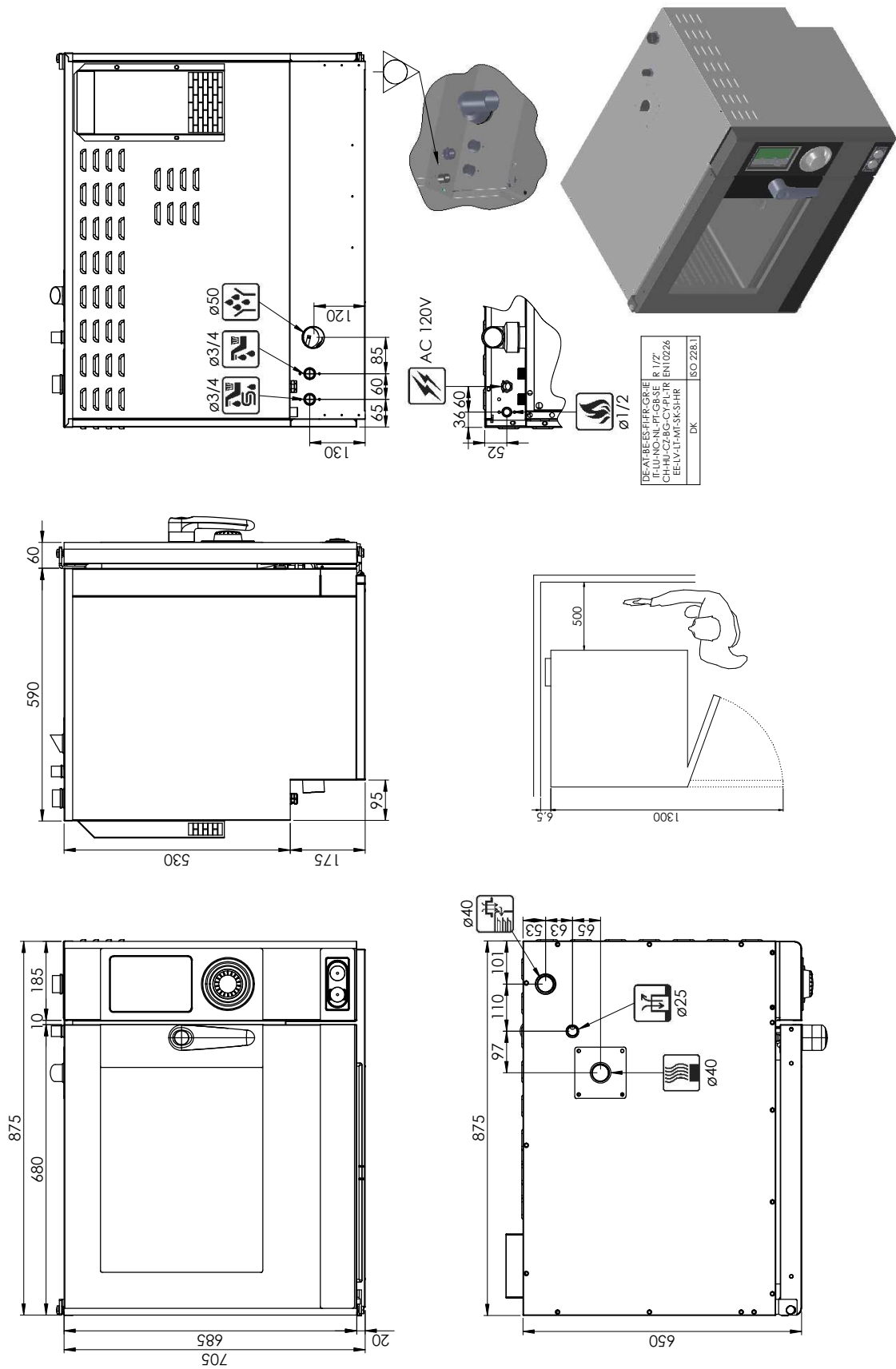

CVEN061 / CVES061 / mm

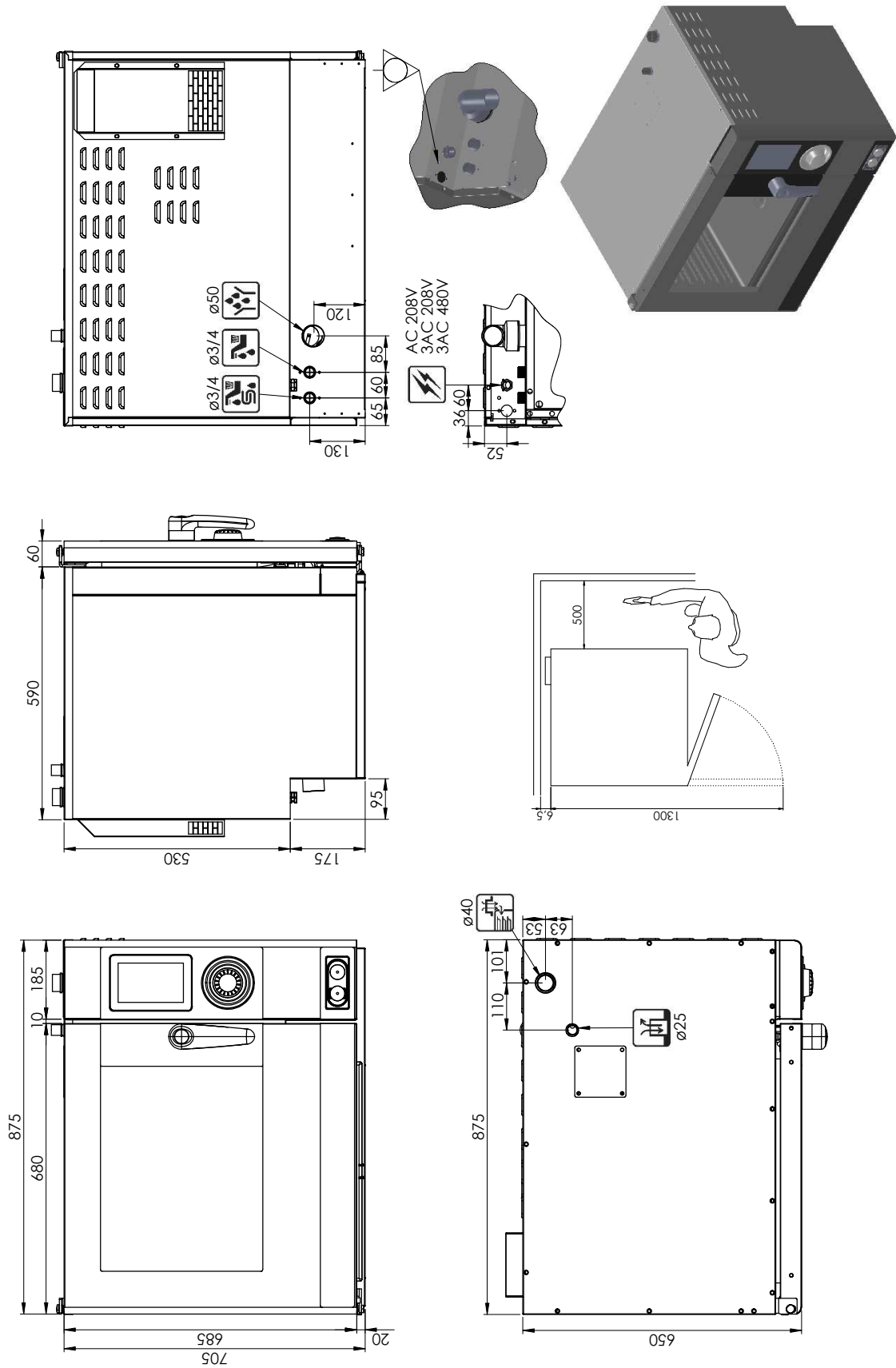

CBEN061 / CBES061 / inch

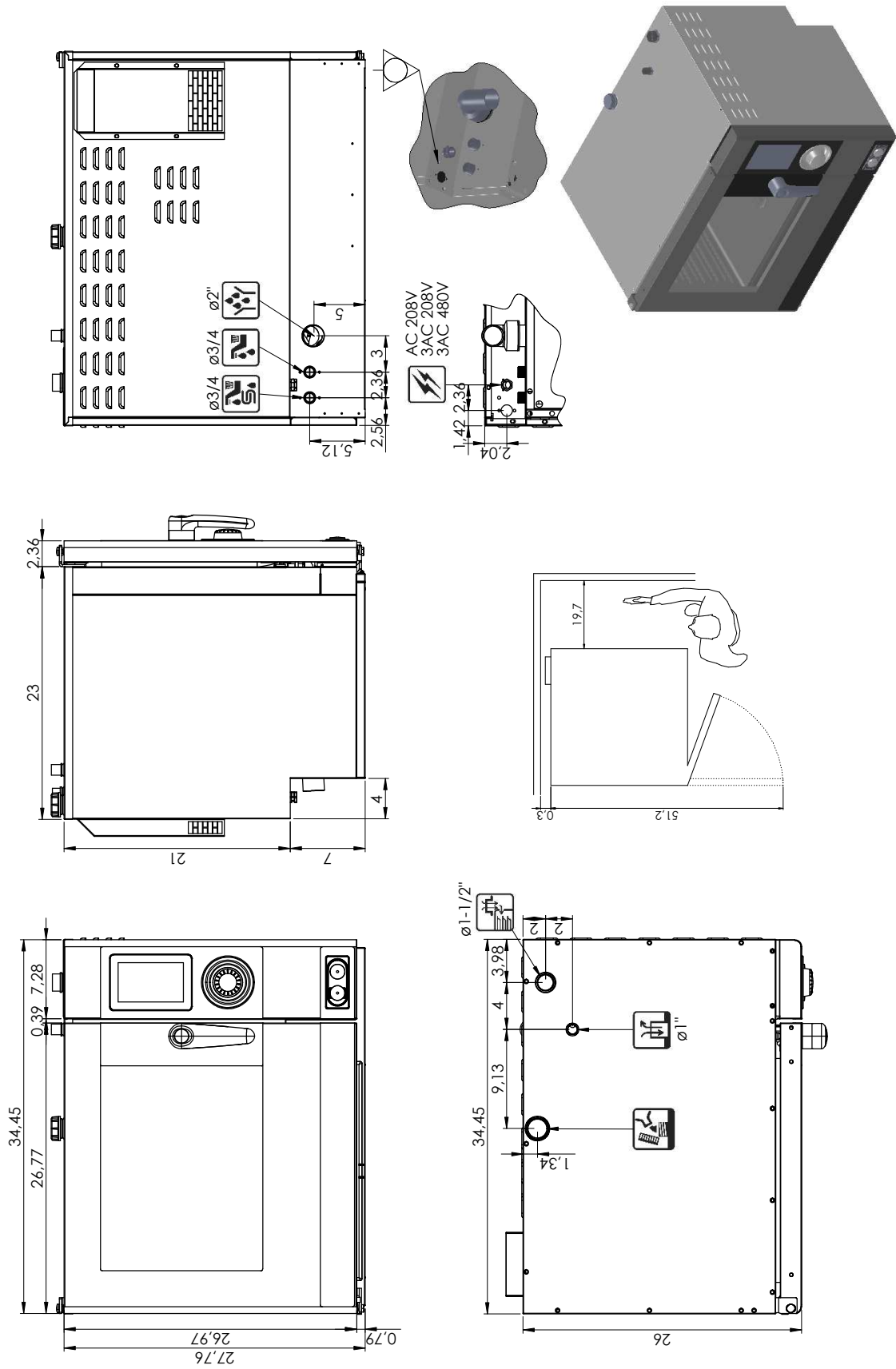

CBEN061 / CBES061 / mm

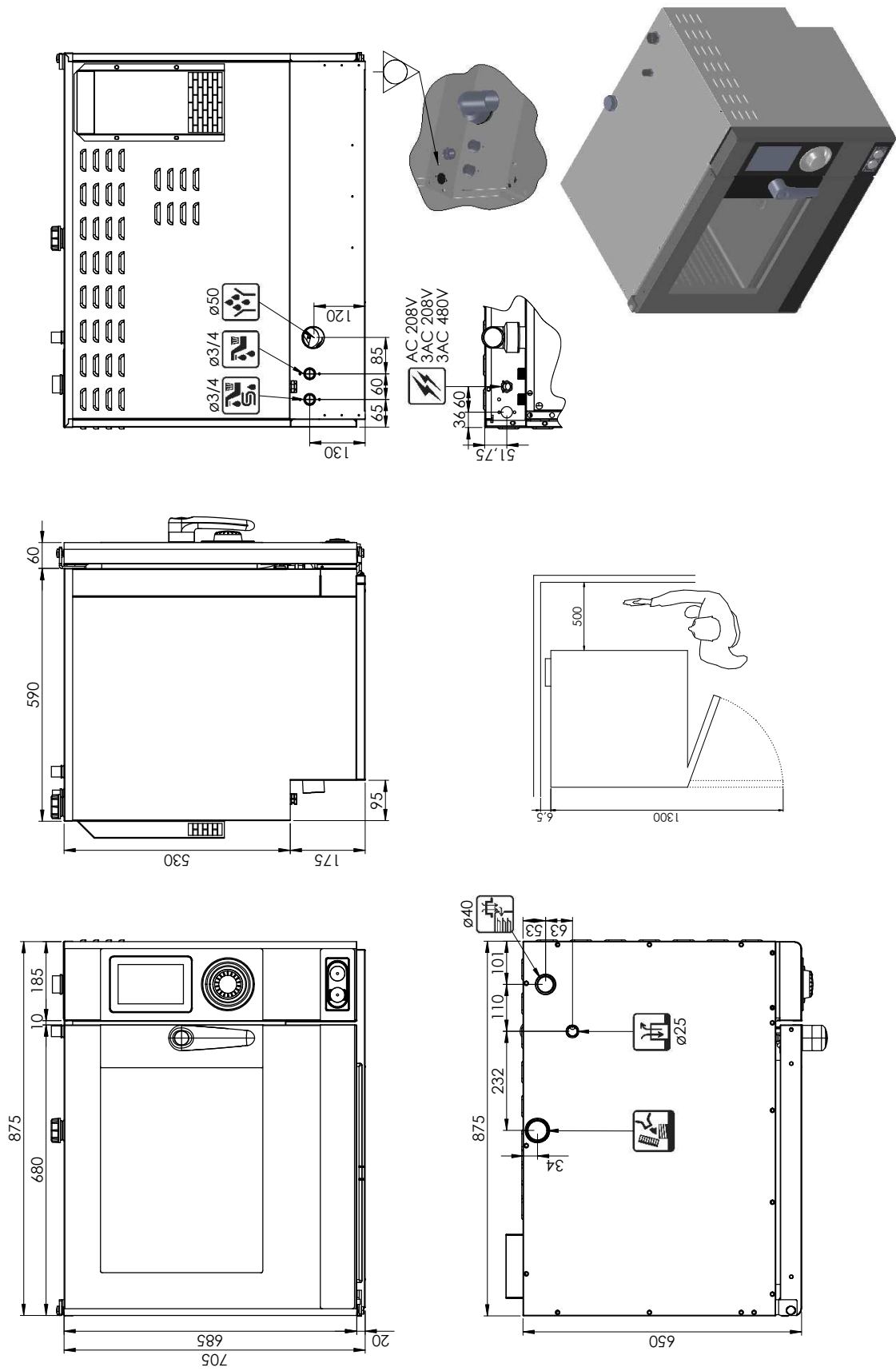

COEN026 / COES026 / inch

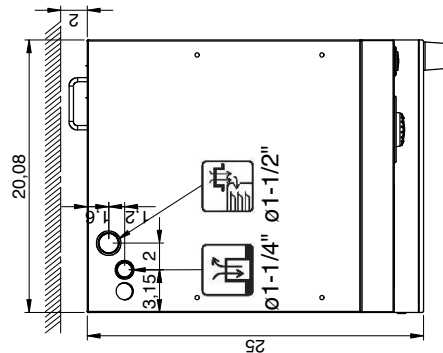
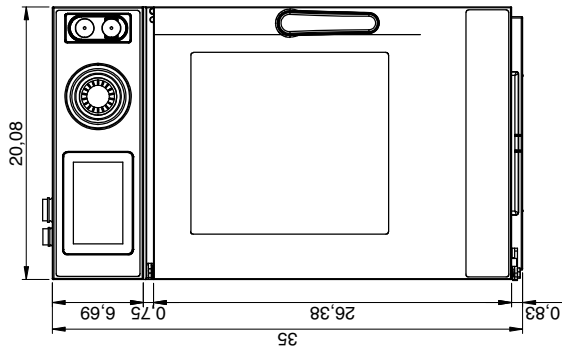
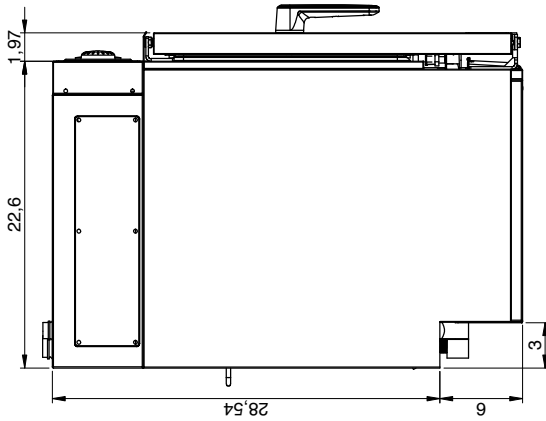
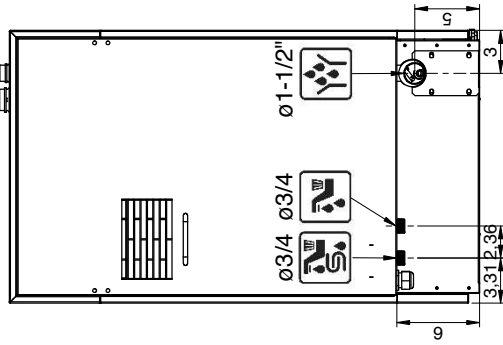
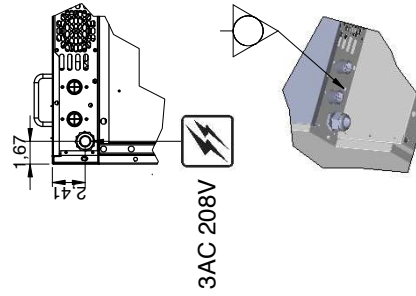
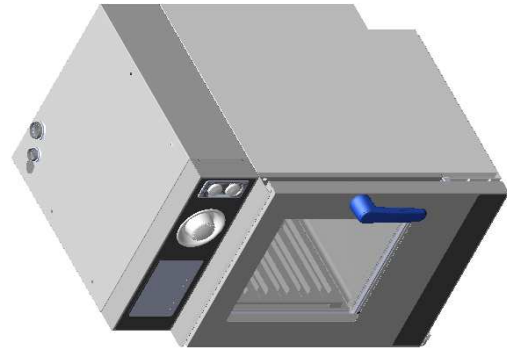

COEN026 / COES026 / mm

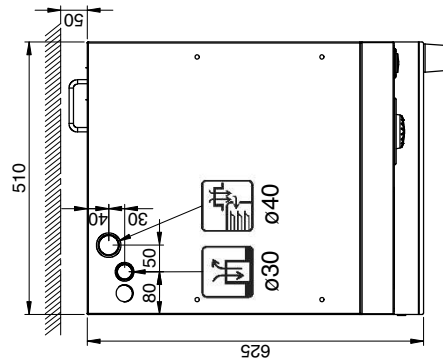
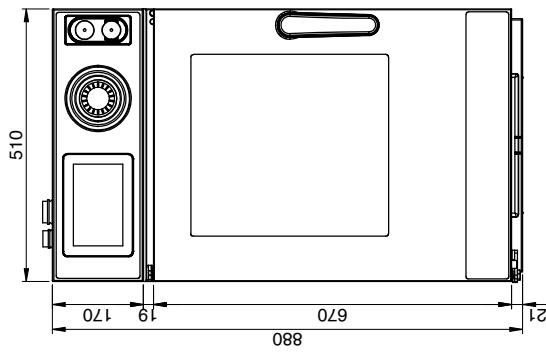
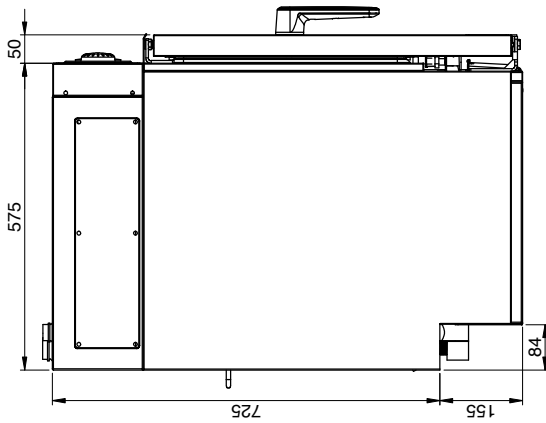
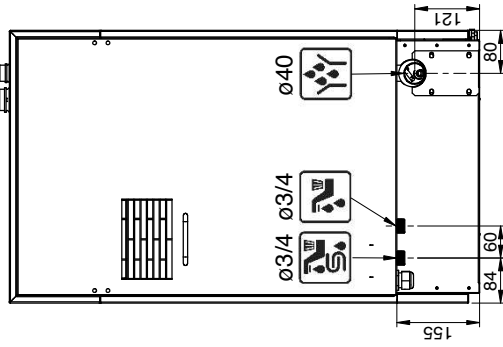
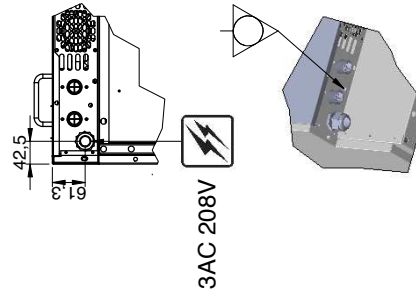
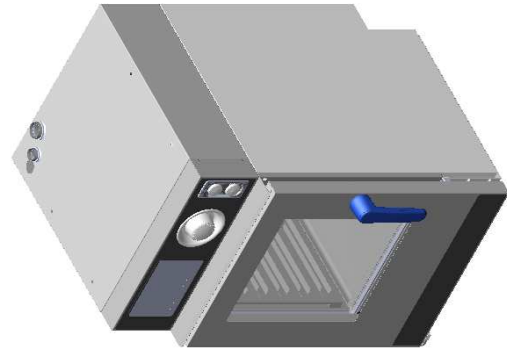

COEN061 / COES061 / inch

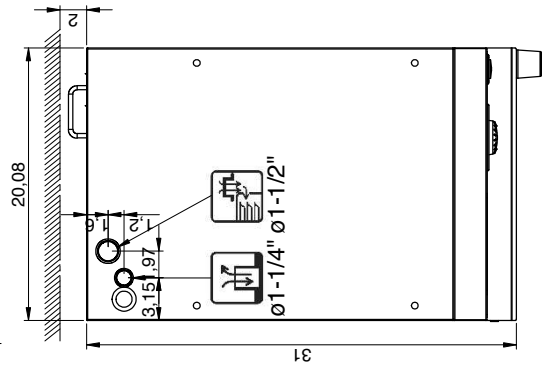
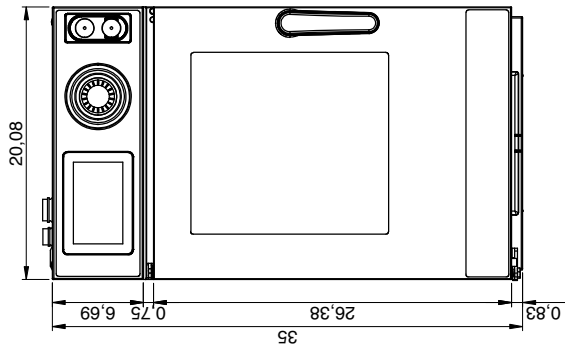
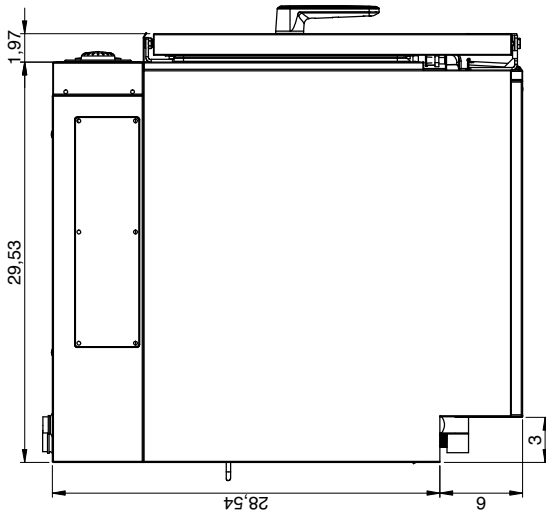
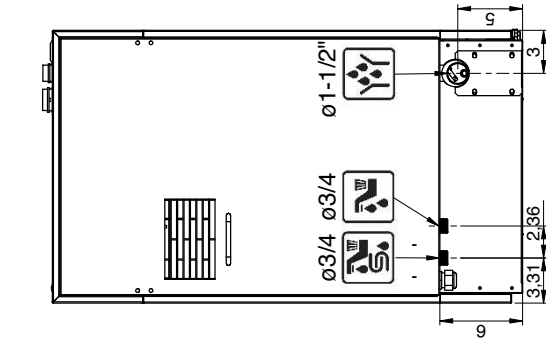
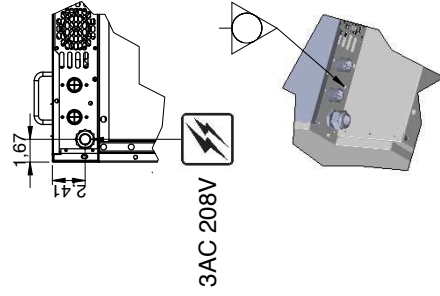
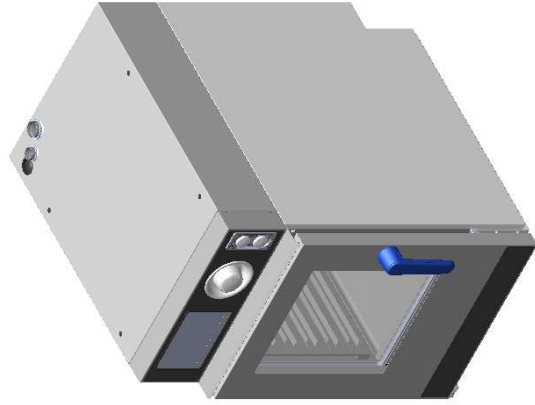

COEN061 / COES061 / mm

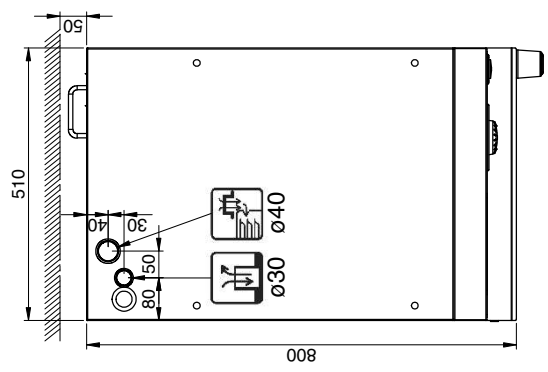
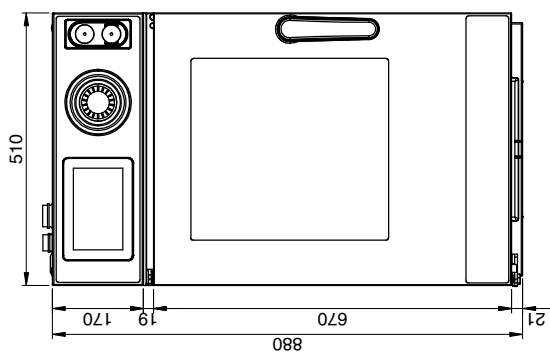
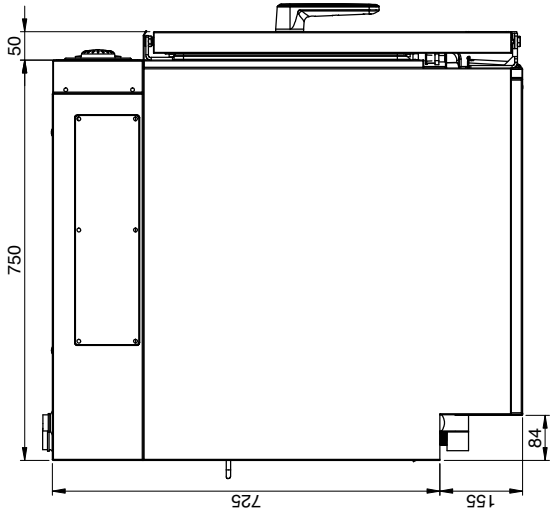
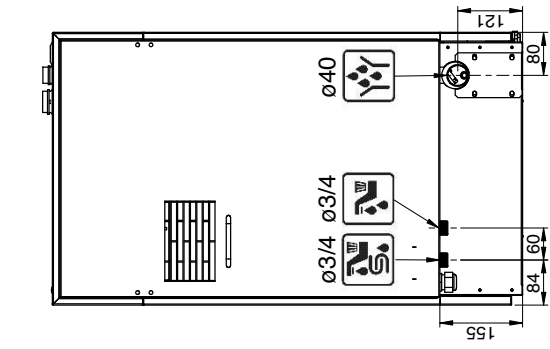
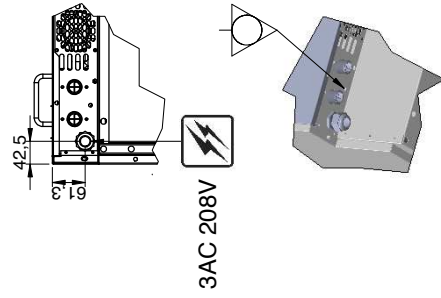
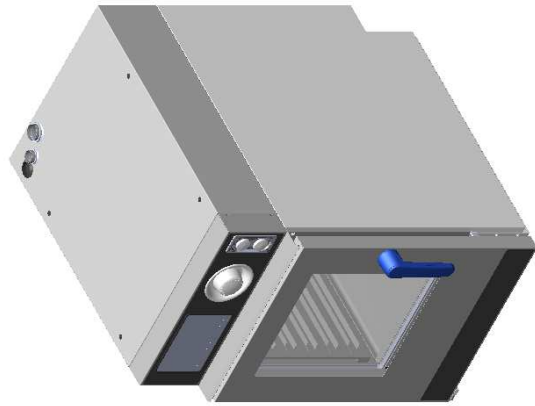

COEN101 / COES101 / inch

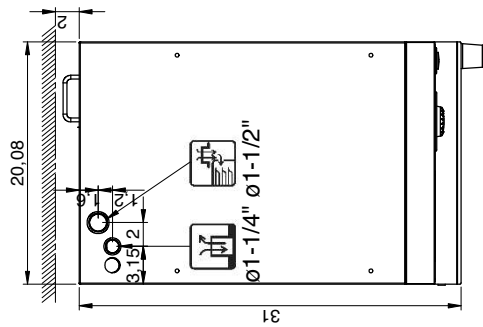
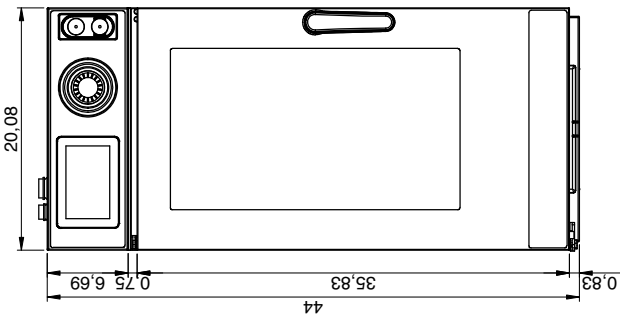
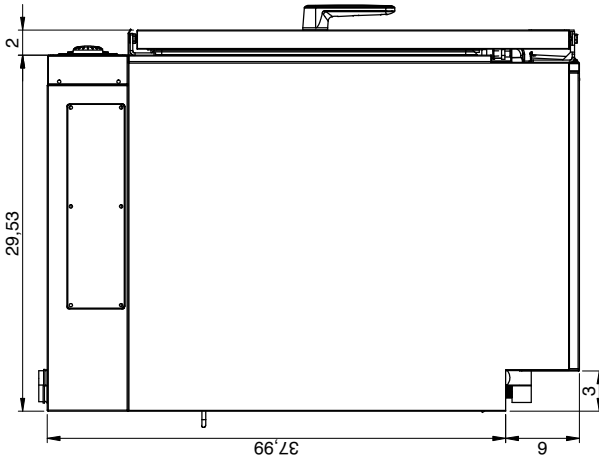
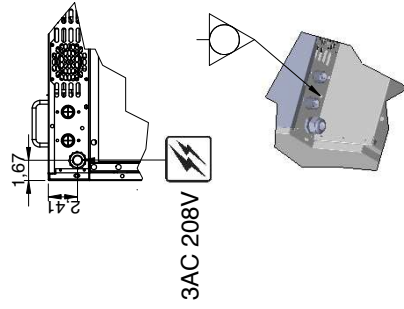
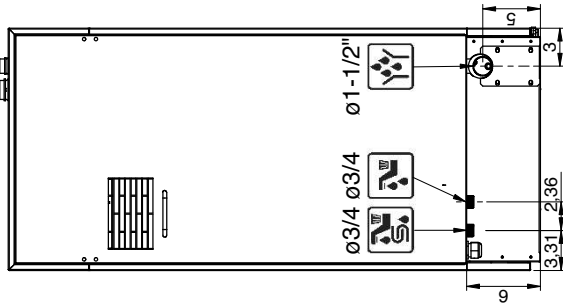
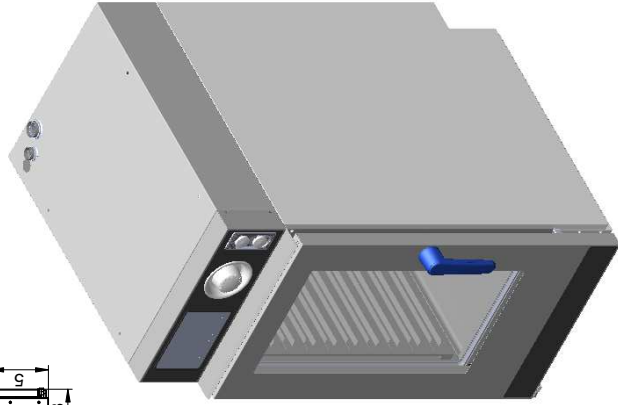

COEN101 / COES101 / mm

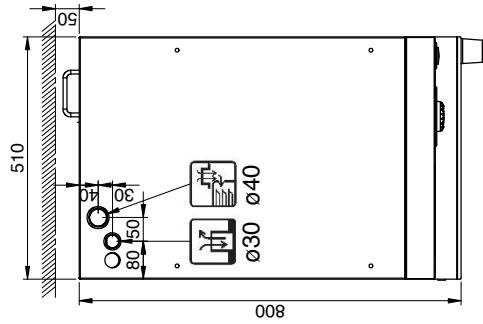
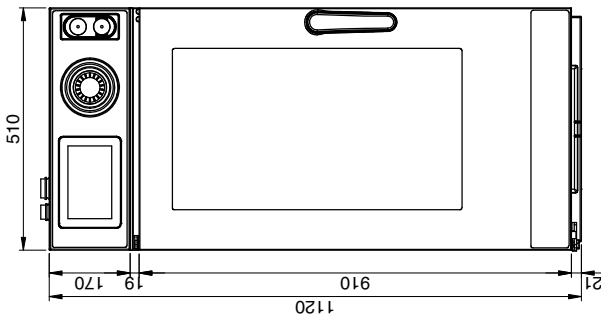
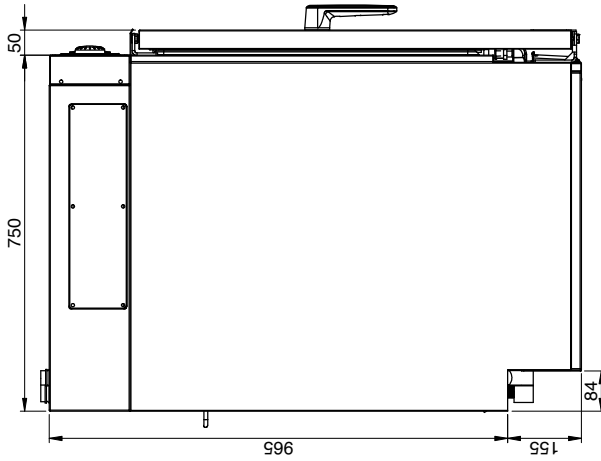
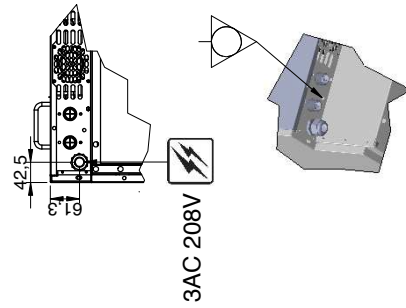
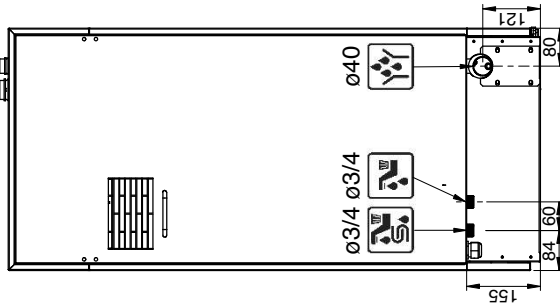
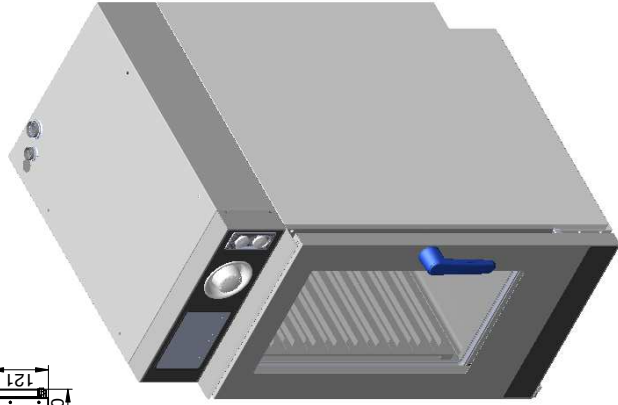

PREPARATION FOR INSTALLATION

Select and prepare the operating location before permanently positioning the unit. Protect the unit and packaged components during site preparation. Do not select the operating location or start installation before checking the electric power, gas, and water quality requirements to assure proper drainage, ventilation, and safety.

UNPACKING AND INSPECTION

The is packed in a wooden shipping crate. The fat filter is packed in a separate box. Additional components, not assembled at the factory are packaged inside the Oven/Steamer cooking Compartment. These are:

Owner's Manual
Wire Shelves

Flue Diverter (optional)
Legs (optional)

After disassembling the shipping crate, visually inspect the for damage.

Before unpacking the separate components, inspect their shipping cartons for damage.

If the cartons are not damaged, unpack them and inspect the components for damage or loss.

- If the and its separate components are delivered in good condition, close and reseal all the component packages. Then proceed to Protecting The Oven/Steamer.
- If any shipping carton appears damaged, refer to the Shipping Damage Instructions below.
- If the or any of the components have suffered shipping damage or loss, refer to the Shipping Damage Instructions below.

Shipping Damage Instructions

If shipping damage or loss is discovered or suspected, observe the following guidelines in preparing a shipping damage claim.

- Write down a description of the damage or the reason for suspecting damage as soon as it is discovered. This will help in filling out the claim forms later.
- As soon as damage is discovered or suspected, notify the carrier that delivered the shipment.
- Arrange for a carrier representative to examine the damage.
- Fill out all appropriate claim forms and have the examining carrier sign and date each form.

PROTECTING THE OVEN / STEAMER

While running power and supply lines to the operating location, remove the and components from the immediate work area. To maintain them in good, clean condition and prevent loss or damage:

- 1- Leave the packaged components inside the cooking compartment.
- 2- Keep the fat filter and together to prevent loss.
- 3- Keep the clean by covering it with a plastic tarp or drop cloth.
- 4- Do not store other items on top of the machine.

PROTECTING THE OVEN / STEAMER

Electric Power Requirements

The characteristics of the electric power supply must match the power requirements specified on the Oven/Steamer product identification plate.

The plate is secured to the outside of the right-side access panel as illustrated in Figure

2-2. Gas Supply Requirements

WARNING

NEVER EXCEED 14"/355.6 mm WATER COLUMN (1/2 psi) GAS PRESSURE.

If the gas supply pressure exceeds 14"/355.6 mm water column, a pressure regulating valve must be installed in the gas supply plumbing to reduce the gas pressure to less than 14"/355.6 mm water column.

- Natural gas pressure must be between 4.5"/101.6 mm - 14"/355.6 mm water column.
- Propane gas supply pressure must be between 11"/304.8 mm - 14"/355.6 mm water column.

WATER QUALITY REQUIREMENTS



Cold or hot water (max. 122 °F/50 °C) for steam generator and humidifier.

WARNING

Using water not within the limits specified in this manual could void or adversely affect the warranty coverage of the Oven/Steamer.

As with any steam generating equipment, poor water quality degrades Oven/Steamer performance. If feed water is low in Total Dissolved Solids (TDS) and free of particulate matter, the steam generator, heating element, and valves of the Oven/Steamer will give years of trouble-free service with a minimum of maintenance.

In some areas, even potable tap water contains a variety of impurities that can cause costly problems in steam generating equipment.

Of primary concern are mineral salts and other impurities which remain behind as lime or scale deposits during the steam generating process. These deposits have caused many components to fail, including heating elements, probes, and solenoid valves.

Of equal importance is the decrease in heat transfer efficiency caused by lime and scale deposits. Decreased heat transfer increases water and power consumption. Use of the in areas with poor water quality requires installation of a Steamer Gard water treatment system or increased frequency of maintenance, cleaning, and descaling.

Check the quality of supply water before starting construction of the water supply lines. If a water treatment system must be installed to achieve acceptable water quality, install it before connecting the water supply lines to the Oven/Steamer.

WATER QUALITY REQUIREMENTS

Contact a local water treatment specialist for an on-the-premises water analysis. The recommended minimum feed water quality requirements for the Oven/Steamer are listed in Table 2-2.

Table 2-2. Minimum Supply Water Quality Requirements

Total Dissolved Solids	less than	60	parts per million
Silica	less than	13	parts per million
Alkalinity	less than	0	parts per million
Chloride	less than	30	parts per million
pH factor	greater than	7.5	

Softened, Treated, or Filtered Water

Do not use softened or chlorinated water in the steam generator.

If the water supply is treated or softened either by the water company or on the premises, it may contain chlorine or various salts.

These additives are damaging to the steam generator. Salts used to soften water cause rapid scale buildup, and increased corrosion.

The hardness of the water has to be from 1 ÷ 4 degrees Clark (1 to 6 fH/0.5 and 2.8 dH). Some water treatment plants kill bacteria in the water by adding chlorine.

When heated in the steam generator, chlorinated water rapidly dissolves generator walls and heater elements. In extreme cases, poisonous and highly corrosive chlorine gas is released in the steam generator. Installing a high volume water filtering system removes most of the salts used for water softening. Contact a local water treatment specialist or the local water company for assistance with chlorinated water.



Always connect an untreated cold water supply to the steam quenching and boiler rinsing water supply line. **DO NOT USE HOT WATER.**

The oven/steamer will not function properly or within design safety limits if hot or warm water is supplied.

WATER SUPPLY SYSTEM



Select a water supply system that fulfills the following elements: the two different inlet water supplies (softened and untreated) must provide a minimum dynamic pressure of 35 psi (2.4 kg/cm²) and a maximum static pressure of 60 psi (4.1 kg/cm²). If the static pressure exceeds 60 psi, a pressure regulator must be installed in the supply lines. Refer to page 33 for detailed pressure and fitting requirements, and for the recommended plumbing layouts.



If analysis shows that the supply water is NOT within the required limits, install a Steamer Gard water treatment system. Figure 2-6 on page 33 illustrates a treated water supply arrangement.

If analysis shows that the supply water is NOT within the required limits, and it is not possible to install a Steamer Gard water treatment system, plan on increasing the frequency of maintenance, cleaning, and descaling beyond that recommended in the maintenance schedule (Chapter 4).

SELECTING THE OPERATING LOCATION

For safe and efficient operation, observe the following criteria when selecting an operating location for the Oven/Steamer.

WARNING

The flooring directly under this unit must be made of non-combustible material.

- 1- Do not install these units in areas where combustibles are stored or may accumulate. The surrounding area must be clear of combustibles, including the space under the unit.
- 2- A proper air supply for combustion and ventilation air is critical for safe, efficient operation of Oven/Steamers. The area around the oven/steamer must have adequate ventilation for gas-fired-appliances.
Air openings around the unit should not be blocked; provide adequate clearance for proper air flow to combustion chamber.
- 3- The vents for combustion and ventilation air are on the right side of the unit. Do not block these air vents. Do not install any heat producing equipment near the air vents of the unit.

WARNING

All clearance requirements above, below, and around the unit are the same for combustible or non-combustible locations.

Maintain at least 20"/500 mm clearance on the right side of the unit.

Maintain at least 10"/254 mm clearance at the rear of the unit.

- 
- 4- The dimension drawings (Figure 2-2) specify all dimensions and clearances required for proper operation and service of each Oven/Steamer covered in this manual.
 - 5- The service access panel is on the right side of the unit. Select an operating location that allows access to the right side of the unit for service.
 - 6- **CBE** models have electric steam generators
Units have from two to four exhaust ports on the top (see on the dimensions drawing).
A chimney, flue plenum, or exhaust hood should be close enough to extend an exhaust duct to these ports.
 - 7- The location selected must be capable of supporting the operational weight of the unit, including the weight of water and food.
The Oven/Steamer operating weights are listed on the dimension drawings.
 - 8- The floor surface under the unit must be level and continuous with the flooring in front of the unit. The cart must roll smoothly into the for ease of operation and maintenance of the door-to-cart compartment seal.

INSTALLATION INSTRUCTIONS

After selecting and preparing the Oven/Steamer operating location, the oven/steamer can be positioned and installed. When installation is complete, perform all start-up checks to verify proper installation and operation.

POSITION AND LEVEL THE OVEN/STEAMER

NOTE: If there is not enough clearance behind the to install the drain, electrical, and water lines, skip this procedure and continue with Install and Connect the Free Air Vented Drain Lines. After installing all necessary drain, electrical, and water lines, return to these instructions and install the unit.

The is positioned and leveled twice. First level the main unit in position. Then place the roll-in cart in the cooking chamber, and adjust the unit level to match the roll-in cart.

WARNING

Malfunctions and equipment damage may result from improper mounting. Malfunctions and/or damage resulting from improper mounting are not covered by the equipment warranty. The MUST BE LEVEL BOTH FRONT TO BACK AND SIDE TO SIDE in all mounting arrangements. Equipment damage may result from shifting the Oven/Steamer more than 3° out of level while power is turned on.

Adjustable Leveling Legs only if present

The supporting legs of the Oven/Steamer are 12 inch/304.8 mm long when the adjustable feet are fully retracted. The adjustable feet can be extended approximately 2 inches/50.8 mm. This extension provides the 4 inch/101.6 mm space below the unit required by NSF sanitary standards, and a means of leveling the oven/steamer.

ASSEMBLY

- 1- Check that the feet are fully retracted into the legs. Do not overtighten. The feet should easily screw in and out using fingers only.

WARNING

INJURY AND EQUIPMENT DAMAGE could result from improper lifting. Refer to the appropriate dimension and check the weight of the unit being installed. Use enough workers with experience of lifting heavy equipment to place the on the supporting surface.

- 2- Be sure electric power is turned off at the main power switch. Place the on the left side.

3- Refer to figure 2-3 and bolt the legs to the Oven/Steamer frame. All four legs must be installed for proper mounting of the unit.

4- Place the oven/steamer upright on its four legs.

Figure 2-3. Leg Bolts

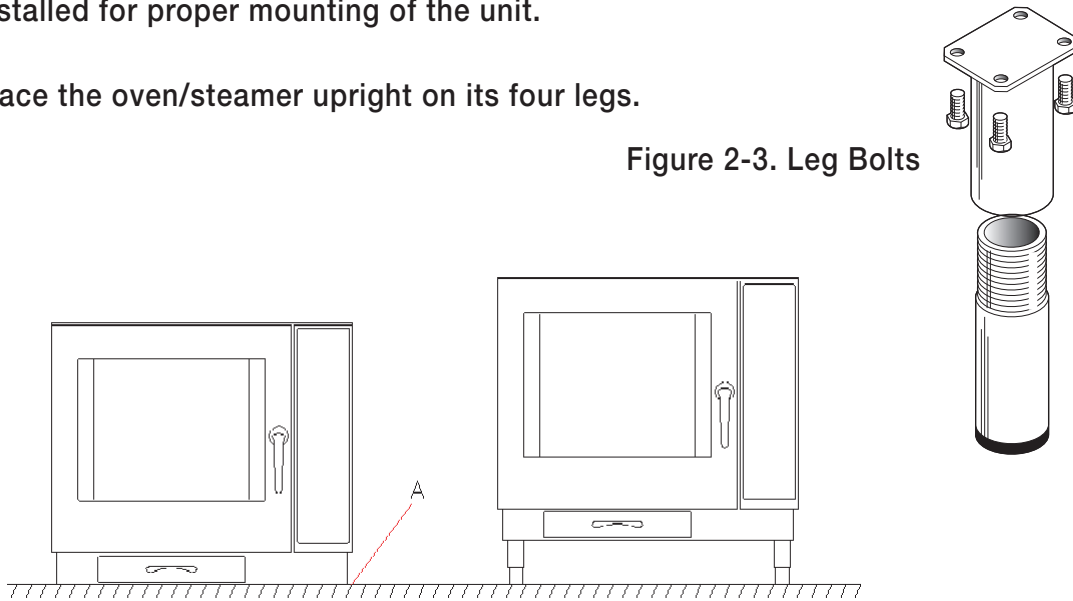

Oven placed on counters, if placed on a plane different from the one suggested by the producer, must be sealed (see point A, fig. X) along all its perimeter with silicon approved by NSF (type GE – red, aluminum ore transparent coloured silicones, series RTV), on the plane. The above said is not valid if oven is equipped with feet, supplied upon specific request.

Positioning and Leveling

- 1- Check that all Unpacking and Inspection tasks are complete.
Thoroughly clean the floor area that will support the unit.
- 2- Using a level, determine and mark the highest corner of the floor area that will support the leveling legs.

WARNING

INJURY AND EQUIPMENT DAMAGE could result from improper lifting. Refer to the appropriate dimension and check the weight of the unit being installed. Use enough workers with experience of lifting heavy equipment to place the on the supporting surface.

- 3- Roll the cart out of the cooking compartment, and move the into position and level it.
- 4- Extend the adjusting foot of the leg in the highest corner (marked in step 3), until that corner of the unit is four inches above the supporting surface.
- 5- Using a level, adjust the other three legs until the is level both front to back and side to side.

POSITION AND LEVEL THE OVEN/STEAMER

For free-standing models, the appliance needs to be levelled: small differences in level of the supporting surface can be eliminated with the adjustable feet (by screwing or unscrewing them). A significantly uneven or sloping stance can affect the operation of the oven adversely.

APPLIANCE EQUIPPED WITH CASTERS

ELECTRIC

- Adequate means must be provided to limit the movement of the appliance without depending on or the transmitting stress to the electrical conduit.
- The appliance shall be installed using flexible conduit.



GAS-FIRED

- The installation shall be made with a connector that complies with the Standard for Connectors for Movable Gas Appliances, **ANSI Z21.69 – CSA 6.16**, and a Quick-Disconnect Devices for Use With Gas Fuel, **ANSI Z21.41 – CSA 6.9**.
- Adequate means must be provided to limit the movement of the appliance without depending on the connector and the quick-disconnect device or its associated piping to limit the appliance movement.

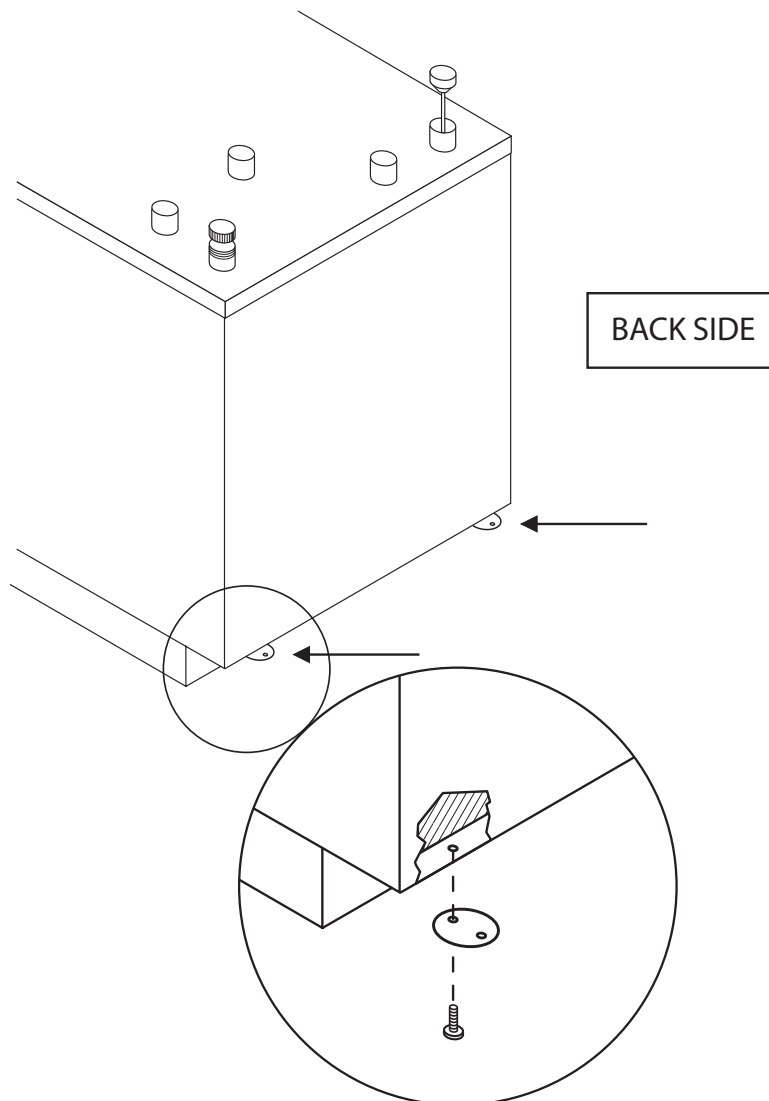
Locations where the restraining means may be attached to the appliance





INSTALL AND CONNECT THE FREE AIR VENTED DRAIN LINES

The drain outlets and the drain vent at the top of the unit  and  must be free air vented to equalize the pressure in the with the atmosphere.

Generating steam causes pressure to increase in the unit; cold water flow into the condenser creates a vacuum (low pressure) in the condenser. Without a free airvent, either high or low pressure in the compartment will cause malfunction or damage.

- Pressure build up in the steamer will cause steam and hot water leakage around the door.
- A vacuum will implode the steamer and cause permanent physical damage.

Refer to Figure 2-4, and the dimension drawings (Figure 2-2). The drain outlet  discharges exhaust steam and hot condensate from the oven/steamer.

The drain exhaust vents ( and ) and a 1 inch/25 mm minimum clearance between the drain opening and floor provide the with free air venting.

Furnishing and installing the drain lines and fittings is the responsibility of the owner and/or installer. Figure 2-4 illustrates a drain layout recommended by the Manufacturer.

The drain line: Use a heat-resistant plastic pipe (not flexible), installed without loops or kinks and no longer than 2 metres with a slope of no less than 4 degrees, or realize a drain line with a gravity flow away from the unit. Drain line must not be connected to the drain lines of any other equipment. In compliance with current standards, the drainage piping must not be connected in a straight line.

CONNECT THE FREE AIR VENTED DRAIN LINES

Figure 2-4. Recommended

Drain Layout

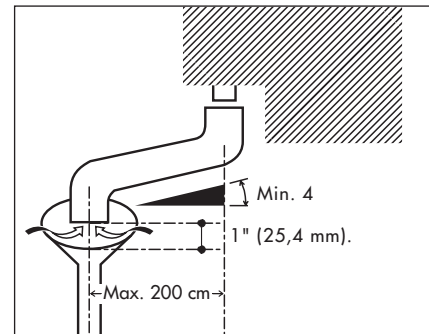
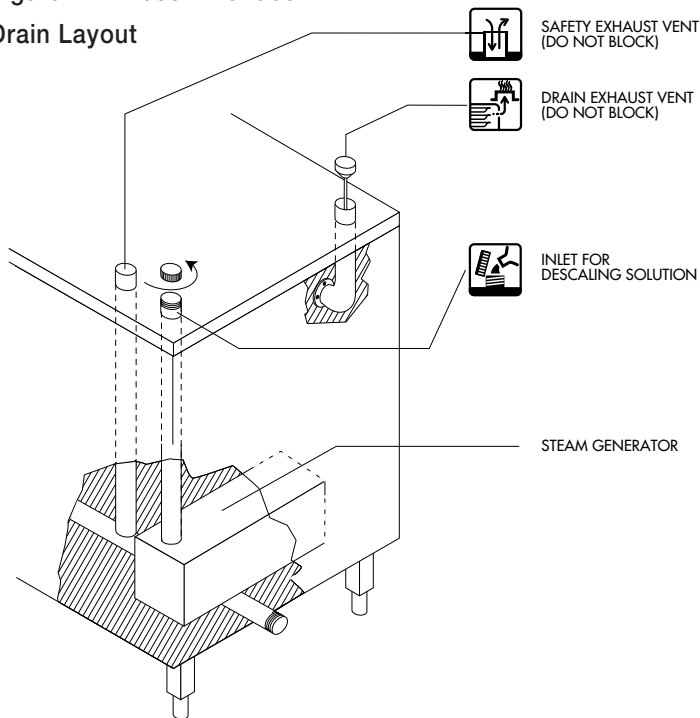

Draining

The water is drained off by gravity through a heat-resistant pipe DN 50 (2"), maximum length 2 m, installed at an angle of no less than 4°. Mean temperature of the drain water: 180°F/82°C.

It is imperative to fit a drain cup to ensure a minimum air drop of 1" (25 mm). between the appliance's plastic drain elbow and drain line. A direct connection is not permissible.

WARNING

The drain line must be outside the perimeter of the oven. It is prohibited to reduce the drain diameter.

INSTALL AND CONNECT THE FREE AIR VENTED DRAIN LINES

WARNING

DEATH, INJURY, AND EQUIPMENT DAMAGE could result from improper installation of the drain outlet lines.

Improper installation of these lines could void the warranty.

The following restrictions are critical to the safety of personnel and equipment, and must not be violated under any circumstances.

Do not connect the drain line into PVC pipe, or any other drain material that cannot sustain 180 °F/82 °C.

Do not connect drains from any other equipment to the Oven/Steamer drain line.

Do not connect the drain outlet extension line directly to a floor drain or sewer line.

Do not block drain vents at the top of the unit ( ).

- 1- The drain lines must be installed in compliance with the Basic Plumbing Code of the Building Officials and Code Administrators International, Inc. (BOCA), and the Food Service Sanitation Manual of the Food and Drug Administration (FDA).
- 2- The total length of pipe and number of bend fittings required to reach the open drain determines the pipe size used to extend the drain line to an open drain.
 - If the drain outlet extension requires twelve feet or less of pipe, and no more than two elbows are required, use 2" / 50 mm pipe and fittings.
- 3- The drain line must have a gravity flow from the drain outlet to the floor drain. Do not install a trap in the drain line.
- 4- Free air venting requires a minimum of 1"/25.4 mm clearance between the end of the drain line and the top of the floor drain.
- 5- Do not connect the steamer drain to drains or plumbing of any other equipment. If drains of two or more units are connected together:
 - Low pressure can develop, causing an implosion and physical collapse of the Oven/Steamer.
 - Drainage from another unit can flow back into compartment of Oven/Steamer.
- 6- When assembling the drain pipes and fittings, apply a hardening type pipe sealant to the threads, and thread them together FINGER TIGHT ONLY. DO NOT USE A WRENCH.

EXHAUST PORT VENTILATION

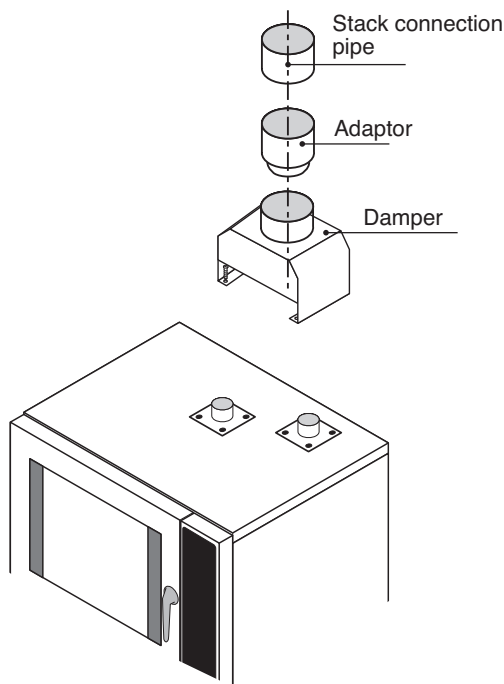

Figure A

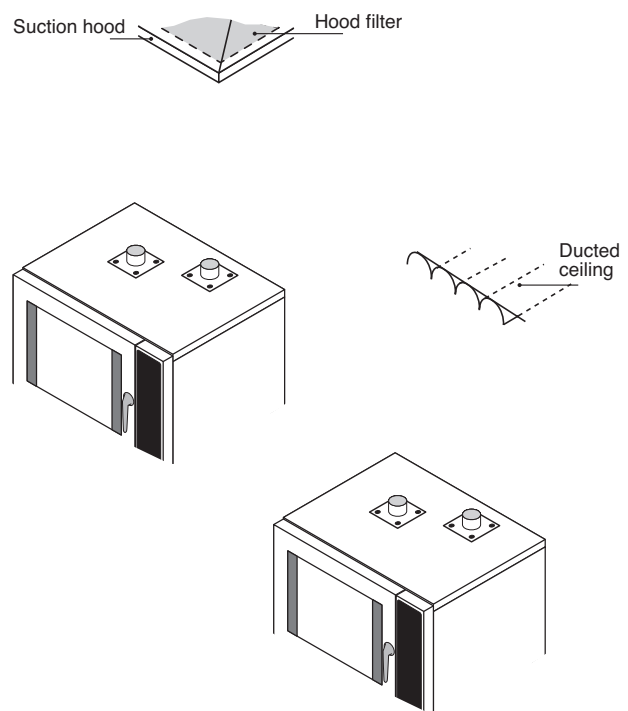

Figure B

NOTE: In case oven equipped with canopy is installed under a commercial ventilation hood, respect minimum distance “D” between canopy and commercial ventilation hood
 $D = “d” \times 1.25 = 1.25$ times canopy port diameter.

Appliance suitable for connection to a flue gas vent when used with draft hood (provided as optional).

Appliance to be installed under a ventilation hood when draft hood is not provided.

- 1- Refer to exhaust ports 1 (steam generator) and 2 (chamber) on the appropriate dimension drawings. These ports must be vented to an exhaust flue by the Flue Diverter.
- 2- A ductwork connection must comply with all local and national codes for venting gas-fired appliances. After sizing and positioning the collars secure them tightly to the exhaust ports.
- 3- Fit the flue diverter using 4 fixing screws for this purpose.
- 4- The oven can also be installed without the flue diverter under a commercial ventilation hood (see Figure B).

When venting to an exhaust hood, the hood must be sized to the ventilation requirements of the Oven/Steamer installed.

EXHAUST PORT VENTILATION

EXHAUST PORT VENTILATION

- Do not connect these ports directly to a forced draft exhaust system or canopy.
- Respect the maximum distance between the flue diverter and canopy (Figure A).
- Excess draft through the flue reduces the oven's efficiency and may affect cooking times.

- 5- Do not block for any reasons the ports or reduce their dimensions.

INSTALL ELECTRIC POWER LINE

Furnishing and installing the electrical power lines switches, fuse box connectors and accessories is the responsibility of the owner and/or installer.

Figure 2-5 illustrates an electrical layout recommended by the Manufacturer.

When installing the electrical power lines and accessories, observe the following instructions.

- 1- Install the electrical power and ground lines in accordance with local codes and/or the National Electric Code, ANSI/NFPA No. 70-(latest edition) (USA), or the Canadian Electrical Code, CSA C22.1.
- 2- Refer to the electrical schematic diagram that was shipped with the unit, and also stuck up on to the right side access panel (inside).
- 3- Install the proper size disconnect switch, circuit breaker or fuses, and wire and conduit to conform to all local codes and the national codes cited above (see Technical Data pag. 13).
- 4- Install a separate disconnect switch and fuses or breakers sized to meet the line amps required by the Oven/Steamer (see see Technical Data pag. 13).
The fuses or breakers may be an integral part of the disconnect switch or in a separate fuse box. Install the disconnect switch for easy access as needed for emergency shutdown. Throughout the remainder of this manual the fused disconnect switch is referred to as the main power switch.
- 5- There should be a sufficient length of flexible conduit between the Oven/Steamer connector and the wall so the unit can be moved for service.
- 6- Each must be electrically grounded by the installer in accordance with the National Electric Code, ANSI/NFPA No. 70-(latest edition), or the Canadian Electrical Code, CSA C22.1.

INSTALL ELECTRIC POWER LINE

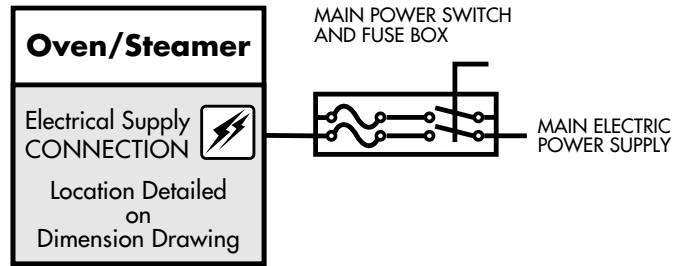

Figure 2-5. Recommended Electrical Layout

- 7- The characteristics of the electric power supply must match the power requirements specified on the product identification plate.
The plate is located on the right side of the unit in the bottom left corner. Also refer to the electrical schematic diagram that was shipped with the unit, included at the end of this manual.



CONNECT ELECTRICAL LINE

Refer to the electrical schematic diagram and connect the electrical lines to the terminal block inside the right side access panel as described below. Copies of the electrical schematic diagrams are included at the end of this manual and a copy was shipped with the unit and also stuck on the right side access panel (inside).

- 1- Remove the right side access panel by removing the screws that hold it in place. Save the screws.
- 2- Refer to the electrical schematic diagram that was shipped with the unit.
- 3- Mechanically secure the flexible conduit to the electrical access hole.
- 4- The terminal block and ground connection are near the center of the side opening. Connect the wires to the terminal block and ground connector accordingly.
- 5- The oven/steamer must be electrically grounded by the installer in accordance with the National Electric Code, ANSI/NFPA No. 70-(latest edition), or the Canadian Electrical Code, CSA C22.1.
- 6- If no further work inside the side panel is required at this time, such as plumbing and leak checks, secure the right side access panel with the mounting screws.

INSTALL AND CONNECT WATER SUPPLY LINES

Furnishing and plumbing the water supply lines is the responsibility of the owner and/or installer. This section explains the plumbing layouts recommended by the Manufacturer. When installing and connecting the water supply lines to the Oven/Steamer, observe the following guidelines and instructions.

- 1- The Oven/Steamer has compression fittings at the back of the unit for connection to the water supply lines. The steam generator and humidifier fitting ( on dimension drawing) is 3/4" IPS and the condenser and boiler rinsing fitting ( on dimension drawing) is 3/4" IPS.
- 2- Always connect untreated COLD water supply to the Oven/Steamer condenser/boiler rinsing water supply line. DO NOT USE HOT WATER. The Oven/Steamer will not function properly or within design safety limits if hot or warm water is supplied.
- 3- Do not connect the to a softened or treated water supply which adds chlorine or chloride salts to the water. Refer to the Softened, Treated, or Filtered Water instructions on page 21 for details.
- 4- Supply water must have a minimum dynamic pressure of 35 psi (2,4 kg/cm²) and a maximum static pressure of 60 psi (4.1 kg/cm²). Water pressure greater than 60 psi will cause damage to the solenoid valves. Local water pressure can be 100 psi or more. If possible, check supply pressure at non-peak demand time. A local water company can assist in this check. If static pressure exceeds 60 psi water, a pressure regulator must be installed in the supply lines. For best results, set the regulator for 50 psi dynamic pressure.
- 5- Refer to the recommended plumbing layouts in Figures 2-6 and 2-7, and install the water supply lines and fittings in accordance with all local and national codes. While constructing and installing the water supply lines, pay particular attention to the following requirements and recommendations.

WARNING

This equipment is to installed with adequate BACKFLOW that complies with FEDERAL, STATE, OR LOCAL CODES having jurisdiction

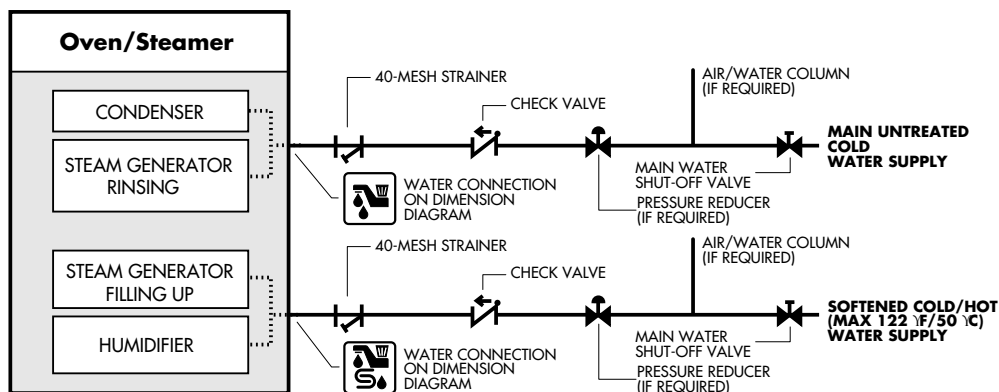

Figure 2-6. Water Supply Lines without a water treatment system

INSTALL AND CONNECT WATER SUPPLY LINES

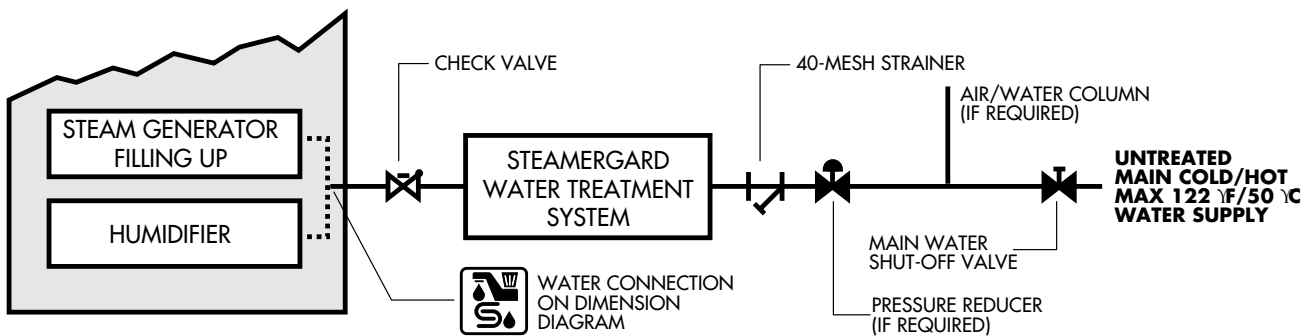





Figure 2-7. Water Supply Lines water treatment system

- a. Apply pipe dope or teflon tape to any threaded connection
- b. When installing a water supply system without a water treatment system, we recommends the plumbing layout illustrated in Figure 2-6.
 -  Install a single water line from the main untreated cold water supply to the water solenoid valve outside the for the condenser and the steam generator rinsing.
 -  Install a single water line from the main softened cold/hot (max. 122 °F/50 °C) water supply to the water solenoid valve outside the for the steam generator filling up and humidifier.
- c. When installing a water supply system with a water treatment system, we recommends the plumbing layout illustrated in Figure 2-7.

Install a single water line from the untreated main cold/hot (max. 122 °F/50 °C) water supply to the water solenoid valve before the water treatment system.

 - The water supply line from the water treatment system connects to the steam generator fill and humidifier connection.
 - The cold water supply to the condenser and steam generator rinsing connection can be untreated
- d.   Use 3/4" lines for the steam generator/humidifier, and condenser and steam generator rinsing lines respectively.

If larger lines are used, a pressure regulator must be installed in the supply line to maintain the pressure specified in step 4.
- e. Install a manual water valve between the main cold water supply line and the Oven\Steamer lines.
- f. The National Sanitation Foundation (NSF) requires installation of a check-valve in all supply lines in accordance with and as required by local plumbing codes.

The recommended locations for check valves are shown in the recommended plumbing layouts.
- g. We recommends installing a 40-mesh water strainer at the locations shown in the recommended plumbing layouts.

INSTALL AND CONNECT WATER SUPPLY LINES

- 6- Construct all supply lines up to the point of installing the strainer(s). Before connecting the strainer(s), flush the water supply line(s). Then install the strainer(s) at the indicated location(s).
 - Make sure the arrow on the strainer body points in the direction of flow into the oven/steamer fittings.
 - Install the strainer so the access nut points down.
 - If the remaining water lines and/or water treatment system are not installed and connected immediately after flushing, temporarily cap the strainer outlet(s) to prevent blockage.
- 7- Construct the remainder of the water supply lines but do not connect them to the Oven/Steamer.
 - a. If the Oven/Steamer is installed with a water treatment system, refer to figure 2-7, and the water treatment system manual for detailed instructions.
 - The 40-mesh strainer must be installed at the water treatment system inlet.
 - A check valve must be installed between the water treatment system and the Oven/Steamer steam generator inlet.
 - The line from the water treatment system must connect to the Oven/Steamer 3/4" steam generator inlet.
 - b. If the Oven/Steamer is installed without a water treatment system, refer to Figure 2-6. Note that the tee is installed after the check valve and strainer to reduce the number of fittings and amount of piping required.

Before connecting the water supply lines to the Oven/Steamer, flush the lines.

Then connect the water supply lines to the at the locations shown in the appropriate dimension drawing (Figure 2-2).

TESTING WATER SUPPLY LINES

- 1- Check all connections for proper tightness.
- 2- Remove the right side access panel to inspect water connections inside the steamer.
- 3- Open the water supply valves.
- 4- Check all lines and connections for leakage, both inside and outside the oven/steamer. If no other inspections are being made at this time, replace the right side access panel.

INSTALL AND CONNECT GAS SUPPLY LINE

- 1- Furnishing and installing the gas supply lines, valves, regulators, and accessories is the responsibility of the owner and/or installer. When installing the gas supply lines and accessories, observe the following instructions.

Install the gas supply lines in accordance with local codes and/or the National Fuel Gas Code, ANSI Z223.1-(latest edition), the Natural Gas Installation Code CAN/CGA-B148.1 and Propane Installation Code CAN/CGA-B148.2.
- 2- Use 1/2 inch gas supply piping and fittings. Refer to the appropriate dimension drawing for pressure data and connection locations.

Refer to Figure 2-8 for recommended layout of the gas supply lines.

INSTALL AND CONNECT GAS SUPPLY LINES

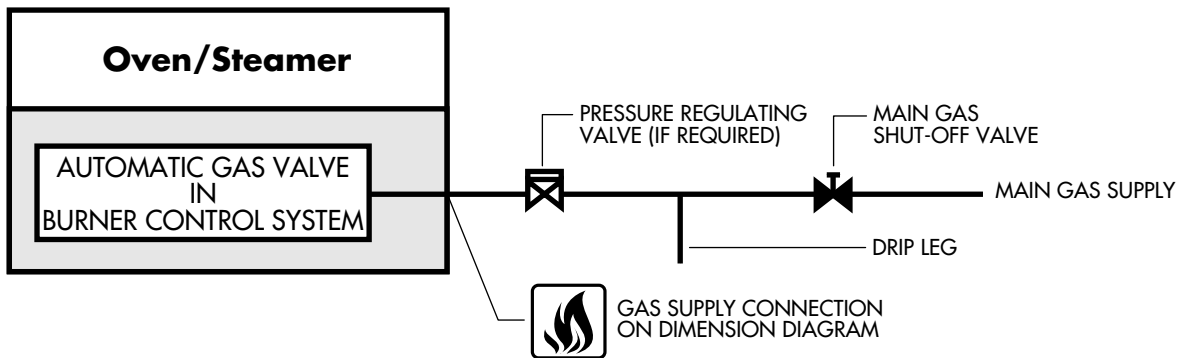



Figure 2-8. Recommended Gas Supply Line Layout

- 3- Install a manual shut-off valve between the gas supply line and the Oven/Steamer gas connection ( on dimension drawing).
- 4- Install a sediment trap (drip leg) in the gas supply line, then connect gas supply piping to the steam generator gas valve piping.
- 5- If natural gas pressure exceeds 14"/355,6 mm water column, a pressure regulating valve must be installed in the gas supply plumbing to reduce the pressure to within the limits specified in Gas Supply Requirements.
- 6- If Propane gas is supplied, use a gas pipe joint compound which is resistant to Propane gas.

TESTING GAS SUPPLY LINES AND BURNER CONTROLS

After initial installation, both the gas lines and burner controls should be inspected for proper installation and tested for leaks and proper operation. After service or repair, the components affected should be inspected and tested for leaks and proper operation.

Pressure Testing The Gas Supply Lines

The gas lines leading to the Oven/Steamer can be tested immediately after installation, or during the Start-Up Checks. Do not supply gas to these lines until they have been tested. When testing these lines observe the following.

- 1- Remove the right side access panel. Check all internal and external connections for proper tightness.
- 2- Refer to Figure 2-8, and set-up the Oven/Steamer automatic gas valve according to the test pressure being used. The same pressure criteria apply when testing lines prior to the manual gas shut-off valve.
 - The appliance and its individual shut-off valve must be disconnected from the gas supply piping system during any pressure testing of that system at test pressures in excess of 14"/355.6 mm water column (1/2 psi or 3.45 kPa).
 - The appliance must be isolated from the gas supply piping system by closing its individual manual shut-off valve during any pressure testing of the gas supply piping system at test pressures equal to or less than 14"/355.6 mm water column (1/2 psi or 3.45 kPa).

TESTING GAS SUPPLY LINES AND BURNER CONTROLS

- 3- Refer to Figure 2-8, and open the main shut-off valve for the oven/steamer gas supply line.
- 4- Test the pipe joints for leaks with soap and water solution.
- 5- If you smell gas, turn off the main gas shut-off valve.
- 6- If no other inspections or tests are planned at this time, replace the right side access panel; otherwise proceed to the next test. Do not leave manual gas valve open during initial installation or burner control system servicing, until after the automatic gas valve has been tested.

TESTING THE AUTOMATIC GAS VALVE AND BURNER CONTROL SYSTEM

Test the automatic gas valve and burner control system during the initial installation Start-Up Checks, or after servicing any components of the valve or system. If this testing is part of initial installation or if gas line components have been altered, **DO NOT TEST** the automatic gas valve and burner control system until the gas supply lines have passed the pressure test procedure above.

- 1- If this test is part of the initial installation Start-Up Checks, perform checks 1 through 10 before starting this procedure.
- 2- Turn off electrical power to the unit by pressing the main push button.
- 3- Turn off the electrical power to the unit at the main power switch (Refer to figure 2-5, Recommended Electrical Layout).
- 4- Turn the main manual gas valve to the OPEN position. Wait five minutes.
 - If you smell gas, refer to Gas Leak Instruction.
 - If you do not smell gas, continue this procedure.
- 5- Turn on the electrical power to the unit at the main power switch.
- 6- Install the access panel removed at step (4).

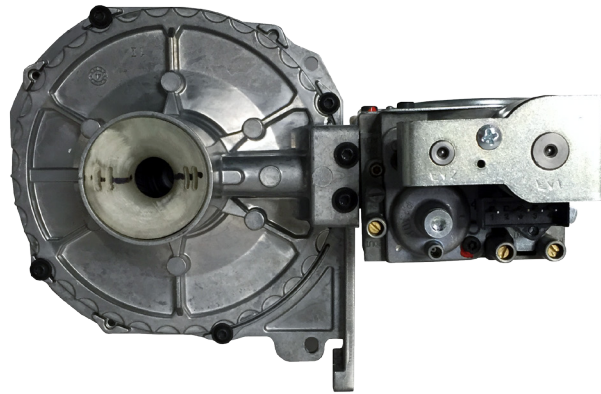

Figure 2-9:
automatic gas valve

NOTE: A smoky, strong smelling vapor fills the cooking compartment and exhaust ports during initial startup. This condition is normal, please refer to Initial Operation and Cleaning, at the end of this chapter.

- 7- The unit is now ready for operation.
- If this test is part of the initial installation START-UP CHECKS, continue the check list with step 14.
 - If this is part of component repair, perform START-UP CHECK number 14 only. If the unit passes the check, it is ready to resume normal cooking operation.

WARNING

**DO NOT TRY TO LIGHT THE BURNERS OR PILOT WITH A FLAME.
THERE IS NO PILOT TO LIGHT OR ADJUST.**

The Combis have electronic ignition systems which automatically light the burners, sense the flame, and control gas flow. This provides both precise burner control and safety ignition and shutdown features.

DEATH, INJURY OR EQUIPMENT DAMAGE may result from an improperly adjusted gas control and ignition system. Do not alter any adjustments on this electronic control or solenoid valve. If adjustment is required, contact an authorized service center. The Manufacturer is in no way responsible for the operation or safety of this equipment if the controller, valve, or igniter probe are adjusted by anyone other than authorized service representative.

START-UP CHECK LIST

This inspection checks proper electrical water and drain connections to the Oven/Steamer, and verifies basic operation of the oven/steamer.

WARNING

Equipment damage and faulty operation will result if the gas, water or electrical supplies fall below requirements. This may be caused by other equipment on the same supply lines. During all tests, adjustments and inspection of the Oven/Steamer, turn on all equipment drawing on the same supply lines.

- 1- Refer to the appropriate dimension drawing and verify that the specified clearances are met.
- 2- Verify that the voltage supplied complies with the voltage requirements specified on the Product Identification Plate located on the right side of the unit in the bottom left corner. Verify that the wiring connections are correct for these voltage requirements.
- 3- Fan rotation: all the appliances have alternating fan motor rotation in order to obtain best cooking results, so that observing the direction of fan rotation is not needed.
- 4- Verify that the flue diverter, fat filter, wire shelves and drip tray are installed and fit properly.
- 5- Verify that the exhaust duct is properly installed between the exhaust ports and flue; or the draft hood is the correct size.
- 6- Verify that the free air vented drain lines are connected properly.
- 7- Check that the drain exhaust port (on the dimension drawing, Figure 2-2) is not closed, blocked or connected to any other equipment.
- 8- Verify that the cooling fan motor works properly; hot air must be exhausted from inside electrical components and void to outside.
- 9- Check the water shut-off valve at the unit and verify that the water is turned on.
- 10- Check that the cart rolls in and out of compartment freely. Check that the door seals properly with the cart in place.

START-UP CHECK LIST

- 11-If not already done during installation, pressure test the gas supply line as described in Testing Gas Supply Lines and Burner Controls.
- 12-**NOTE:** A smoky, strong smelling vapor fills the cooking compartment and exhaust ports during initial startup after installation. Refer to Initial Operation and Cleaning, at the end of this chapter.
- 13-After setting the cooking parameters, the burner should light with a distinctive sound.
- If the burners light within one minute, the unit is operating properly. Proceed to step 16.
 - If the burners do not light within one minute, there may be air in the gas supply lines.
- 14-Verify operation of the no-water safety circuit. Refer to, Operation, and start the oven/ steamer with the main steam switch.
Let the unit fill with water and begin steaming for a few minutes.
Shut-off the water supply at the unit.
The unit automatically shuts off when the water drops to the safety level.
Turn the water supply back on, and the unit automatically fills with water and resumes steaming.
- 15-Refer to, Operation, and verify operation of the hot air, steam and humidification functions.

INITIAL OPERATION AND CLEANING

During shipment, components in the cooking compartment and steam generator are protected by an oily, non-toxic coating. During the first cooking cycle after shipment, this coating vaporizes, filling the cooking compartment and exhaust ports with a smoky, strong smelling vapor. The manufacturer recommends vaporizing and cleaning this coating from the unit before cooking any food.

- 1- Be sure the unit has passed all the tests, inspections, and procedures of the Start-Up Check List before performing this procedure.
- 2- Inspect the cooking compartment and remove any shipping or construction debris. Close the compartment door.
- 3- Spray the inside of the oven/steamer with a grease removing product.
Do not scrub the compartment walls with an abrasive.
Avoid products that are likely to leave an unpleasant smell in the compartment.

LIGHTING INSTRUCTIONS

- THIS OVEN IS EQUIPPED WITH AN IGNITION DEVICE WHICH AUTOMATICALLY LIGHTS THE BURNERS.
DO NOT TRY TO LIGHT THE BURNERS BY USING A MATCH.
- TURN OFF ALL ELECTRICAL POWER TO THE OVEN.
- TURN MAIN GAS VALVE TO OPEN POSITION.
- WAIT 5 MINUTES. IF YOU SMELL GAS, REFER TO “WHAT TO DO IF YOU SMELL GAS”.
- IF YOU DO NOT SMELL GAS, GO TO THE NEXT STEPS.
- TURN ON ALL ELECTRICAL POWER TO OVEN.
- NOW OVEN IS READY FOR DIFFERENT COOKING CYCLES.
- ACTIVATE START SWITCH.
- IF THE BURNERS DID NOT LIGHT, WAIT 5 MINUTES, CUT THE ELECTRIC POWER OFF, TURN POWER TO ON POSITION.
- IF THE BURNERS DO NOT LIGHT AFTER THE SECOND ATTEMPT, CALL YOUR LOCAL SERVICE REPRESENTATIVE OR DEALER.

SHUTDOWN INSTRUCTIONS

- TURN OFF ALL ELECTRIC POWER.
- TURN MAIN MANUAL GAS VALVE TO OFF POSITION.

Introduction

Maintenance on the Oven/Steamer must be performed on a regular basis to keep the unit running properly. Follow the maintenance instructions in this chapter and problems will be kept to a minimum. As with any preventive maintenance schedule, the frequency of oven/steamer maintenance must be increased if necessary, depending on equipment usage and water quality. If problems do occur, refer to Troubleshooting Guide in this chapter. For more information on equipment and services, contact your nearest authorized service representative.

Maintenance records

Make a file solely for maintenance records. Keep a written record of daily, weekly, and yearly maintenance.

These records will protect warranty coverage, help personnel to know when to perform various maintenance procedures, and assist service personnel.

Each record should include at least:

- The date of the service or maintenance.
- A description of the service, maintenance or repair performed. Include part numbers if applicable.
- Copies of purchase order(s) and invoice(s) for repair parts and service.
- The name and signature of the person performing the maintenance or service.

WARNING

DEATH, INJURY, OR EQUIPMENT DAMAGE may result from improper service or maintenance practices. Always turn the main power switch to **OFF** for any unit before starting service, maintenance or repairs.

PREVENTIVE MAINTENANCE AND TROUBLESHOOTING

DAILY MAINTENANCE

Blowdown Steam Generator

Blowdown the steam generator at least once every 8 hours according to Steam Generator

Cleaning

Clean interior and exterior of the four according to Cleaning and Shut-Down instructions.

Inspect the Cooking Compartment Vent

Cooking vapors leave the compartment through the compartment exhaust vents



labeled and on the dimensions drawings. Before operating the Oven/Steamer, check that these vents are clear of obstructions. Do not block or canalize.



WEEKLY MAINTENANCE

Clean Drain

WARNING

Steam leaks around the door, cooking compartment flooding, reduce cooking performance, and compartment implosion can be caused by a blocked compartment vent, or a blocked drain or drain screen. Inspect and clean the compartment vent, drain and drain screen before each use.

Never operate the oven/steamer without the screen in place.

Pouring USDA approved drain cleaner through the compartment drains once a week will help to ensure an open drain. A manual (hand crank) drain auger, or “snake”, may be safely used to clear obstructions in the compartment drains.

Do not use a power auger, as damage to the drain system will result.

- 1- Inspect the drain screen and drain line for blockage. Rotate the drain screen 90 degrees to inspect the drain opening.
Clean the opening and restore the screen to its operating position.
- 2- Clean drain with a USDA approved drain cleaner once a week. Follow the instructions of the manufacturer of the cleaner.
- 3- Flush drain with clean water.

Descale steam generator

Steam generator should be descaled at least once a week, depending on scale buildup.

If you have serious steam generator buildup, install a water treatment system for the oven/steamer.

PREVENTIVE MAINTENANCE AND TROUBLESHOOTING

Immediately you notice that the oven is not performing as it should, descale the boiler hopefully you won't be too late. Use a specific product intend for descaling; do not use powdered sulphonic acid material, liquid phosphoric acid. The following chart lists steam generator capacities. Please observe the Manufacturer's instructions regarding the quantity of descaling product to be used, refer to the chemical manual for service and maintenance.

Descaling should be performed by personnel experienced or trained in the handling of caustic materials, or specifically trained and experienced in descaling the Oven/Steamer steam generator. Only authorized service representative can perform and/or train operating personnel to perform proper, safe descaling of this equipment. Refer to Authorized Service and Repair below to schedule or training.

Follow hazard and leak cleanup procedures on acid container label. If the label is not readable, refer to the following hazard and emergency instructions as a minimum safety precaution.

THESE INSTRUCTIONS ARE FOR USE WITH PHOSPHORIC ACID ONLY

Health Hazard Data, effects of Overexposure - Product is extremely irritating to eyes and may result in eye burns.

Product is severely irritating to skin and can result in skin burns; repeated or prolonged contact with more dilute solutions may result in dermatitis.

Aerosol mist or vapors are irritating to respiratory tract, eyes and throat.

Prolonged exposure to high concentration may result in pulmonary edema. If ingested, it may result in abdominal hemorrhage with severe abdominal pain, nausea, vomiting and loss of consciousness; necrosis of stomach and gastrointestinal tract may also occur.

Emergences and First Aid Procedures - In case of contact with eyes, immediately flush eyes with plenty of water for at least 15 minutes. Seek medical aid.

In case of contact with skin, immediately wash with soap and plenty of water for at least 15 minutes while removing contaminated clothing. Seek medical aid.

If inhaled, move to fresh air. If not breathing, give artificial respiration. If breathing is difficult, give oxygen. Seek medical aid. If swallowed, do not induce vomiting.

Give large quantity of water. Seek medical aid. Never give anything by mouth to an unconscious person.

PREVENTIVE MAINTENANCE AND TROUBLESHOOTING

Spill or leak procedures - Limit spill. Cover the contaminated surface with sodium bicarbonate or a soda ash-slaked lime mixture (50-50). Mix and add water necessary to form slurry. Scoop up slurry and wash residue down drain with excess water.

Wash site with soda ash solution.

WARNING

The liquid phosphoric acid in descaling can be harmful if not handled properly.

Follow these basic safety rules for handling and using the acid.

Wear protective clothing when mixing or applying chemical cleaners. Wear rubber gloves, mask and approved cup-type goggles.

Avoid breathing fumes. If liquid comes in contact with skin, flush immediately with large quantities of cold water. Remove contaminated clothing.

If chemical contacts eyes, flush with cold water for a minimum of 15 minutes.

Get immediate medical attention.

If chemical is swallowed or ingested, follow instructions on the chemical container.

Get immediate medical attention.

NOTES

WARNING

DEATH, INJURY, OR ELECTRIC SHOCK can occur by touching electrical components and wires inside the access panel when the main power switch is in the ON position. **NEVER REMOVE THE SERVICE ACCESS PANEL.** Allow only by Authorized Service Representatives to perform service, maintenance, and repairs that require the removal of the service access panel(s).

- 1- All circuits in the oven/steamer stop working if unit overheats or motor is overloaded. Call an authorized service representative.
- 2- All circuits in the oven/steamer stop working if the cavity or steam generator overheats or the motor is overloaded. Call an authorized service representative.
- 3- If the problem is inside the oven/steamer, call an authorized service representative. The manufacturer will not pay for warranty repairs by unauthorized repair centers.
- 4- Repairs to external wiring should be done by a Licensed Electrician.
- 5- Proper installation of the Oven/Steamer is the responsibility of the owner or installer.
- 6- Repairs to external plumbing should be done by a Licensed Plumber.

FOR THE ATTENTION OF THE AUTHORIZED SERVICE REPRESENTATIVE; YEARLY CHECKING:

For all gas models the state of the metal components in direct contact with the source of heat (burners flames) must be checked.

It is therefore advisable to make an annual visible check on the combustion chamber. This precaution is sufficient to prevent irreparable damage to the appliance.

TROUBLESHOOTING NOTES

The manufacturer support a comprehensive network of Maintenance and Repair Centers (regional parts and service distributors) throughout the United States and Canada.

Please contact your nearest distributor for the name of an Authorized Service Agency in your area, or for replacement parts and information regarding the proper maintenance and repair of the equipment.

In order to maintain the various agency safety certifications, only factory-supplied replacement parts should be used. The use of other than factory-supplied replacement parts will make the warranty null and void.



Handwriting practice area consisting of 25 horizontal dotted lines.



A series of horizontal dotted lines for writing, spanning the width of the page.



LA90028771 MANUALE INST. COMPACT By NAB00-SAPIENS USA/CAN - EN