

# 50Hz iT0450 Ice Cube Machine

iT0450 Ice Cube Machine

## Models

- IDT0450A     IYT0450A     IDT0450W



Indigo NXT Series iT0450 Ice Machine on D400 Bin

Designed for operators who know that ice is critical to their business, the Indigo NXT Series ice machine's preventative diagnostics continually monitor itself for reliable ice production. Improvements in cleanability and programmability make your ice machine easy to own and less expensive to operate.

- **New levels of Performance** – Showcasing an average of 9% lower energy consumption, up to 12% increase in ice production and a 19% reduction in condenser water usage and a 5% reduction in potable water usage. . This translates into lower cost of ownership over the life of your machine.
- **easyTouch<sup>®</sup> Display** - New icon based touch screen takes the guess work out of owning and operating an ice machine.
- **Multiple Language Capability** - The easyTouch display is available in multiple languages selected in the initial start-up installation Wizard.
- **Programmable Ice Production** – Now its super easy to program your ice machine to be off at certain times of the day to save money with fluctuating electrical rates. Also programmable by daily ice production volume.
- **Easy to Clean Foodzone** – Hinge front door swing out for easy access. Removable water-trough, distribution tube, curtain, water probe and water pump for fast and efficient cleaning. Selected components are made with AlphaSan<sup>®</sup> antimicrobial.
- **Intelligent Diagnostics** – Provides 24 hour preventative maintenance and diagnostic feedback for trouble free operation.
- **Acoustical Ice Sensing Probe** – Unique patented technology allows for reliable operation in challenging water conditions and environments
- **DuraTech<sup>®</sup> Exterior** – Provides superior corrosion resistant above stainless steel. Innovative clear-coat resists fingerprints and dirt making it easier to keep clean.
- **Available LuminIce<sup>®</sup> II Growth Inhibitor** – Controls the growth of bacteria and yeast within the Food zone keeping the machine cleaner longer. A new indicator in the display keeps you abreast of the operational status.

## Ice Machine Electric

230/ 50/ 1

### Minimum circuit ampacity:

Air-cooled: 5.6 amps  
Water-cooled: 5.3 amps

### Maximum fuse size:

Air Cooled: 15 amps  
Water cooled 15 amps

## Specifications

**BTU Per Hour:**  
3,800 (average),  
and 6,000 (peak)

### Refrigerant:

R410A CFS - Free  
Lowers global warming  
by 48%

### Operating Limits:

- Ambient Temperature Range: 40° to 110°F (4.4° to 43.3° C)  
Water Temperature Range: 40° to 90°F (4.4° to 32.2° C)
- Water Pressure Ice Maker Water In:  
Min. 20 psi (137.9 kPa)  
Max. 80 psi (551.1 kPa)



## Ice Shape



**Half Dice**  
3/8" x 1 1/8" x 7/8"  
(.95 x 2.86 x 2.22 cm)  
Cube weight 5.7 g



**Dice**  
7/8" x 7/8" x 7/8"  
(2.22 x 2.22 x 2.22 cm)  
Cube weight 8.5 g



COMPANY WITH  
QUALITY SYSTEM

6645 06/18



50Hz

Indigo<sup>®</sup> NXT™ iT0450 Ice Cube Machine

**iT0450 on D-400 Storage Bin**

- (A) Electrical Entrance (2) Options
- (B) 3/8" (0.95 cm) F.P.T. Water Condenser Inlet (water-cooled units)
- (C) 1/2" (1.27 cm) F.P.T. Water Condenser Outlet (water-cooled units)
- (D) 1/2" (1.27 cm) Auxillary Base Drain Socket
- (E) 3/8" (0.95 cm) F.P.T. Ice Making Water Inlet
- (F) 1/2" (1.27 cm) F.P.T. Ice Making Water Drain
- (G) 3/4" (1.91 cm) Bin Drain

**Installation Note**  
Minimum installation clearance:  
Top/side: 12" (30.50 cm)  
Back is 5" (12.7 cm)

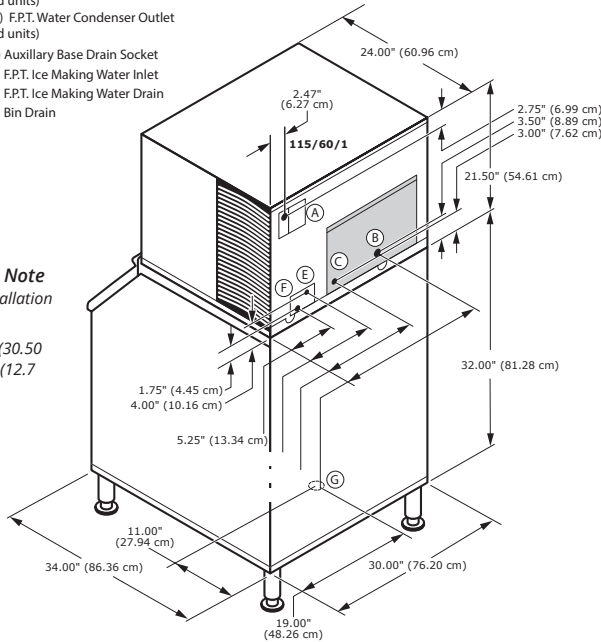

**Space-Saving Design**



|         | <b>iT0450 D-400</b> | <b>iT0450 D-570</b> |
|---------|---------------------|---------------------|
| Height  | 59.50" / 151.13 cm  | 71.50" / 181.61 cm  |
| Width   | 30.00" / 76.2 cm    | 30.00" / 76.2 cm    |
| Depth   | 34.00" / 86.30 cm   | 34.00" / 86.30 cm   |
| Bin     | 365 lbs.            | 543 lbs.            |
| Storage | 165.7 kgs.          | 241.1 kgs.          |

Height includes adjustable bin legs 6.00" to 8.00", (15.24 to 20.32 cm) set at 6.00" (15.24 cm).  
Bin capacity is based on 90% of the volume x 33 lbs/ft<sup>3</sup> average density of ice.

**Specifications**

|                     | Model    | Ice Shape | Ice Production 24 Hours                    |  | Power Usage<br>kWh 45.4 kg / 100 lbs<br>@ 32°Air / 21°C Water<br>90°Air / 70°F Water | Potable Water Usage/100 lbs.<br>45.4 kgs. of Ice |
|---------------------|----------|-----------|--|--|--|--|
|                     |          |           | 21°Air / 10°C Water<br>70°Air / 50°F Water | 32°Air / 21°C Water<br>90°Air / 70°F Water |  |  |
| <b>AIR COOLED</b>   | IDT0450A | dice      | 440 lbs.                                   | 355 lbs.                                   | 5.30   | 19 Gal.  |
|                     |          |           | 200 kgs                                    | 161 kgs                                    |  | 71.9 L   |
|                     | IYT0450A | half-dice | 460 lbs.                                   | 375 lbs.                                   | 5.20   | 19 Gal.  |
| <b>WATER COOLED</b> | IDT0450W | dice      | 420 lbs.                                   | 355 lbs.                                   | 4.88   | 19 Gal.  |
|                     |          |           | 191 kgs                                    | 161 kgs                                    |  | 71.9 L   |

\* Water-cooled Condenser Water Usage / 100 lbs. /45.4 kgs. Of Ice: 140 gal/ 530 L.

Order separately: Ice storage bin for all units  
This product is hermetically sealed and contains fluorinated greenhouse gas R404A

**Accessories**

**LuminIce<sup>®</sup> II Growth Inhibitor**  
reduces yeast and bacteria growth for a cleaner ice machine.



**External Scoop holder**

Protect the ice scoop with the NSF approved versatile scoop holder.



**Arctic Pure<sup>®</sup> Water Filters**

Reduces sediment and chlorine odors for better tasting ice.



Welbilt reserves the right to make changes to the design or specifications without prior notice.

Welbilt Deutschland GmbH  
Auf der Weih 11  
D - 35745 Herboren, Germany  
Tel.: +49 27 72 58 050  
welbilt.com.de

Welbilt Iberia, S.A.U  
Textil, 6 - Pol.Ind. La Ferreria - 08110  
Montcada i Reixac  
Barcelona, Spain  
Tel.: +34 902 20 10 69  
welbilt.com.es

Welbilt UK  
Ashbourne House The Guildway,  
Old Portsmouth Rd Guildford GU3  
1LR United Kingdom  
Tel.: +44 1483 464900  
www.welbilt.uk

