



GREENLINE SERIES SPIRAL MIXER OPERATOR'S MANUAL



Persons under age 18 are not permitted to operate or have accessibility to operate this equipment per U.S. Dept. Of Labor Employment Standards Administration Fact Sheet No. ESA913.

GL REV A

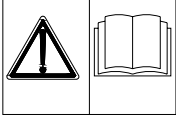

This instructions manual contains necessary directions to use and maintain the machine and it should be kept in area that is accessible to all operators.
The manual has to be read by persons in charge of maintenance and also by workers assigned to the machine.
The manual should not be a substitute for proper machine operation training. It should be used as a guideline and reference for proper operation.

INDEX

SAFETY INSTRUCTIONS	2
WARNINGS	3
DESCRIPTION AND USE OF THE MACHINE	3
OPERATING CONDITIONS	4
IDENTIFICATION OF THE MACHINE.....	4
INSTALLATION	5
CONTROL PANEL	5
OPERATOR INSTRUCTIONS.....	6
CLEANING	7
WARRANTY	7

SAFETY INSTRUCTIONS

Safe and systematic use of the machine is subject to the respect of the below listed behaviours and regulations.

Safety rules

- Personnel has to be in good physical condition, mental condition, and properly trained to use the spiral mixer machine by reading this manual.
- The person in charge of the company safety, operations or department, in choosing the worker to be assigned to the equipment should consider the cultural level, the physical fitness and the psychological aspect (mental equilibrium, sense of responsibility, etc.). The worker needs to be provided with a training, in addition to reading this manual, in order to supply a complete working knowledge of the machine and proper care of the machine prior to and after each use.
- The space around the machine has to be well lit, sufficient for access to controls, sufficient area for adding ingredients and clean/clear of any/all obstructions.
- Do not wear loose/hanging clothes or floating strips (ties, napkins, torn clothes, open jackets, etc), to avoid the risk of getting caught in the moving parts of the machine when is use..
- During maintenance and cleaning phases, the worker has to turn the Main Power Switch (locted on the left hand side of the machine) and make the equipment safe (e.g. removing the plug).
- During the running phase, don't leave the machine unattended, pay attention to noises or anomalous behaviours and stay away from rotary parts.
- At the end of the work, turn off the Mains Power Switch, make the machine safe and clean it with a neutral degreasing.

Safety devices

The machine is provided with some devices that protect its running and the worker safety; they must not be removed or modified and their running has to be periodically controlled.

- Mains Power Switch: Cuts the power off to maintain the machine in safe conditions.
- Inverter power block: Cuts off the power in case of extreme charge of the electrical motor (only with inverter)
- Thermic switch: Cuts the power off in case the electric motor gets overheated.
- Fix protections: All cases and protections fixed by screws or mechanical blocks can be removed only for maintenance, by skilled personnel and in prescribed conditions.
- Mobile protections: The mobile cases must be correctly placed or the machine cannot be used. If these conditions are missed, the machine doesn't work.

WARNINGS



Danger of physical injury from the chute or disassembling the cases during maintenance. It is possible to come in contact with the machine-members in motion. Make the machine safe before performing regular cleaning and maintenance by turning off the Mains Power Switch.



Danger of electric shock if the machine is not properly grounded with suitable earthing. It has to be connected in accordance with the local/state regulations in force in the country of installation..

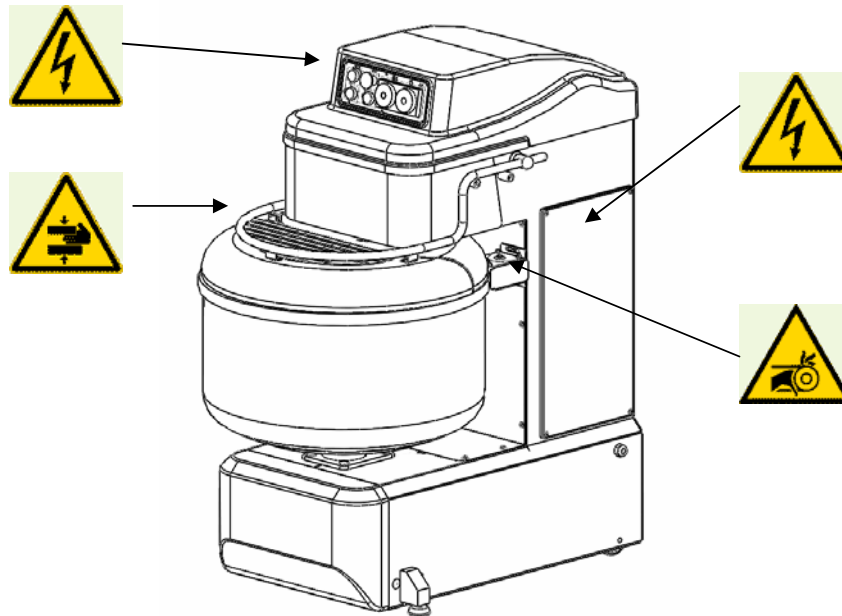

DESCRIPTION AND USE OF THE MACHINE

The Univex Greenline Series Spiral Mixers are composed of a strong structure in steel plate, welded in a monolithic block, with the task to hold up the supports for a stainless steel bowl and a spiral, as mixing element.

In the internal upper part, there are the drive belts that move the spiral and bowl drive shaft.

In the lower part, is the chain drive that rotates the bowl during operation.

In the upright rear of the machine, there is a single motor that operates the machine. As this is a “Green” version with energy conservation, only motor is used.

Operator control panel is located on the front of the machine. Control panel allows for Start/Stop, emergency Stop, two speed timer control and keyed override of individual timer controls. The Mains Power Switch is located on the left hand side of the unit.

The Univex Greenline Spiral Mixer with fixed bowl is designed to mix food doughs that are composed by flour and water, as basic ingredients. A rotating spiral amalgamates, mixes, refines and oxygenate the dough in the bowl.

Designed for the production of bread doughs, the machine is also suitable to mix all the leavened doughs and of all the oven products composed of the following ingredients: flour, water, yeast, fats, butter, spices and colouring agents, allowed by the law, and other ingredients to obtain bread and other confectionery products.

It is suggested to use the mixer for doughs with hydration of about 50%.
For doughs with lower percentage of liquids or for the use of flours with high content of gluten, please contact the manufacturer to set a correct use of the machine.

Dough Capacity

- GL50 110 lb (50kg)
- GL80 176 lb (80 kg)
- GL120 265 lb (120 kg)

OPERATING CONDITIONS

Environmental conditions: The machine needs to be installed inside a well lighted and aired building, on a solid and levelled support. Temperatures from 41°F to 104°F (5°C to 40°C) with humidity not over 90%.

Lighting: The light at worker disposal has to suitable to accomplish the performed work, should be in accordance with regulations and sufficient to read the controls, danger signals. The light should not obstruct the operator's vision or impair it in any way.

- Vibrations: under proper conditions of use, vibrations are not so strong to cause dangerous situations
- Sound emissions: 70 dbA during standard use
- Electromagnetic environment: the machine is produced to work properly in an electromagnetic environment of industrial type



Environments exposed to the risk of explosion: an atmosphere open to be transformed in an explosive atmosphere due to the local and/or working conditions is defined potentially explosive atmosphere.

The machine has not been manufactured to work in environments with potentially explosive atmospheres.

IDENTIFICATION OF THE MACHINE

In the back part of the machine there is a plate like the one you can see below here. That plate shows the details of the manufacturer, the type of machine, the registration number, the electrical characteristics, frequency, absorbed power and number of phases, and the year of manufacture.



3 OLD ROCKINGHAM ROAD, SALEM, NH 03079

TEL. 1-603-893-6191 FAX 1-603-893-1249

www.univexcorp.com

MODEL

Serial Number

Date of Manufacture

Voltage/HZ Phases

kW

INSTALLATION



The machine has to be laid in vertical position, on a level surface with sturdiness suitable for the load. **DO NOT OPERATE MACHINE WITHOUT LEVELING FEET IN PLACE!** Leveling feet need to be adjusted down, such that the front casters are raised off the surface of the floor and the unit is level.

Electric Connection



The electric connection is to be carried out by a skilled electrician, in compliance with the procedures, state/local codes and the regulation in force in the country of installation. Make sure that the voltage and the frequency of the equipment are the same of the identification plate of the machine. Damage to the machine resulting from incorrect electrical connection will void all warranties.

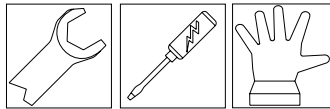

DO NOT REMOVE OR TAMPER THE PROTECTIONS AND THE ELECTRICAL AND MECHANICAL SAFETY DEVICES THAT THE MACHINE IS PROVIDED WITH.

CONTROL PANEL

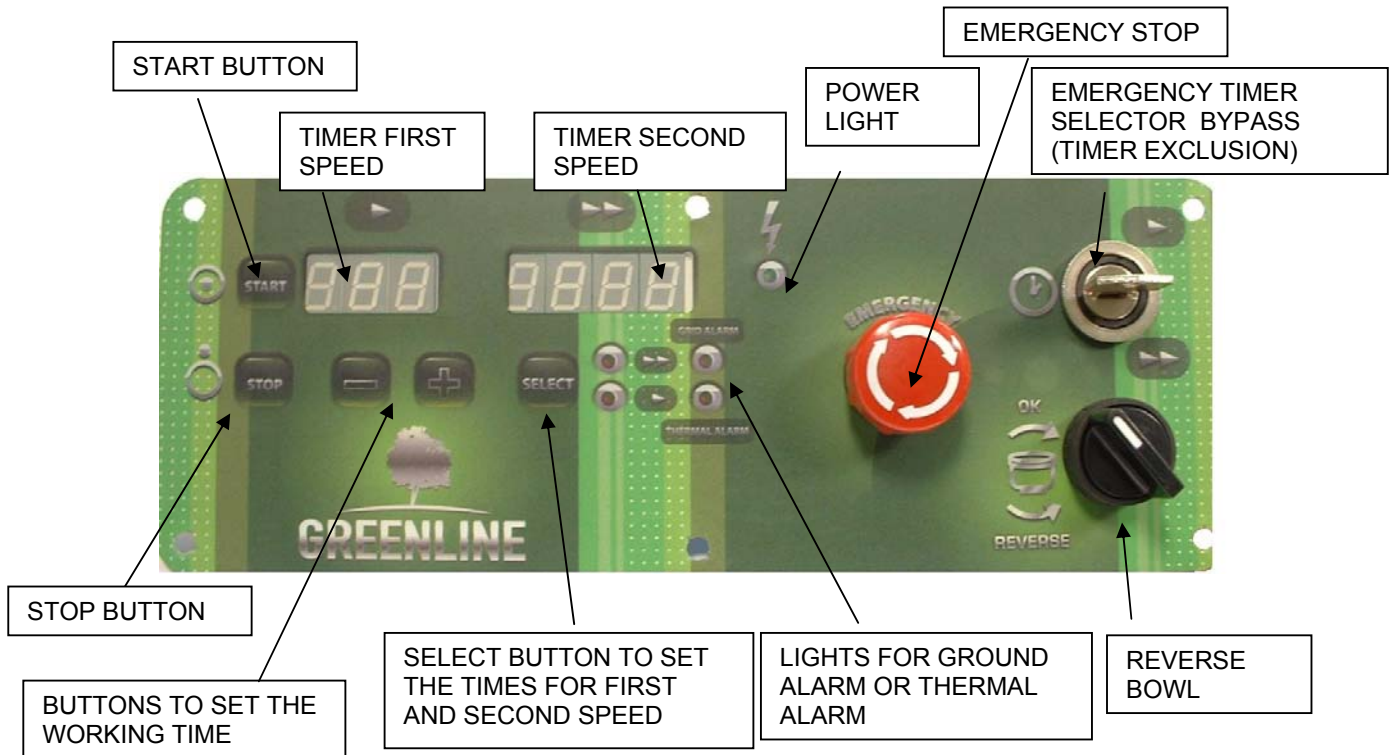

The control panel is used for the operation of the spiral mixer by the user. In order to operate the control panel, the Mains Power Switch (left side of the machine) must be switched on.

Start Button - Begins the mixing operation. Timer(s) must be set or the unit must be in emergency bypass to start.

Stop Button - Stops the mixing operation independent of the timer(s), Emergency Stop and safety switches. Typically used when the timer(s) are being bypassed and the unit needs to stop and restart for the remainder of a timed mix or when the unit is to be shut off when the emergency bypass time has expired.

(+) (-) Buttons - These are used to set the time for the specified speeds. The digital display will show the time in seconds.

► Display - This shows the set time for first speed.

►► Display - This shows the set time for second speed.

Select Button - This is used to select which speed timer is being set.



Light - Power Indicator Light. This light illuminates when the Mains Power Switch is turned on.

GND Alarm - Ground/earthing loss indicator light. Light will illuminate when units electrical earth/ground connection is lost or improperly connected

Thermal Alarm- Thermal overload on motor. Light will illuminate when the motor has shutdown to being overheated.

Emergency Stop – Used to shut down operation. Switch must be rotated clockwise to release.

Emergency Timer Selector Bypass Key Switch - This switch has three (3) operational positions;

- Normal (center, clock face position) which operates with the timer sequences. In this position, the key can be removed.
- Clockwise (►) position bypasses the first speed timer. In this position, the key cannot be removed.
- Counterclockwise (►►) position bypasses the second speed timer. In this position the key cannot be removed.

Reverse Bowl - This momentary switch is used to reverse the direction of the bowl for short periods of time. The switch must be held in order to activate the bowl reversal. It is not recommended to hold the switch for periods greater than fifteen (15) seconds at a time. This switch should be used to assist in the initial mixing of ingredients and to assist in moving the dough mixture away from the spiral at the completion of the mixing.

OPERATOR INSTRUCTIONS

Make sure the bowl and spiral are clean and free of any/all dirt, debris or old mixtures. Turn the Mains Power Switch on (left side of the machine). Add the ingredients to be mixed into the bowl. Close the bowl guard and set the timer(s) for the time necessary for the mixture for either single or dual speed operation. Set the timer by selecting the speed control (first [single arrow] or second [double arrow]). Use the (+) and (-) buttons to adjust the time (in seconds) for the unit to run in the specified speed. Digital readouts on the control panel will indicate the selected time(s) for each speed. If first speed is only going to be used, do not set any time for the second speed. If only second speed will be used, do not set any time for first speed.

Once the timer(s) are set, press the start button to begin mixing. Once the specified time(s) have expired, the unit will shut off automatically. Lift the bowl and remove the dough mixture. Use of a plastic spatula may help in removing the dough. Do not use metal scrapers or utensils to remove the dough as they will damage the finish to the bowl.

Use of the Emergency Timer Selector Bypass should be used only under strict supervision. The use of the Bypass will operate the mixer in the selected speed for an indefinite period of time. It is suggested that person(s) of authority should remove the key when the machine is being operated under normal use. The keyed bypass should only be used when the timer controls become inoperable. A separate timer (operator supplied) will need to be used to make sure the machine is only operated within the specified recipe timeframe. Once the specified time has expired, press the Stop button to stop the mixing operation.

Use of the Reverse Bowl Selector is used to initially assist in mixing the ingredients. The switch is a momentary operation meaning that it must be held in order to reverse the rotation. Releasing the switch will allow the bowl to rotate in its normal direction. The switch can also be used to “jog” / rotate the finished dough product away from the spiral for ease of removal. The switch is not intended to be operated for longer than 15 seconds at a time.

Do not attempt to lift the bowl guard to add ingredients as this will shut the machine down. The bowl guard incorporates a safety switch to ensure that contact with the moving spiral is minimized. **This switch should not be compromised in any way!**

CLEANING

Use a mild detergent and warm water to clean the bowl, spiral and outside of the mixer. The control panel can be wiped down as it is protected with a gasket. **Do not use direct spray or hose to wash this machine!** The machine is not rated for direct spray and water may get into the unit and cause damage. Any damage as the result of water entering the unit due to direct spray or immersion of the machine will void all warranties.

WARRANTY

The Univex Greenline Series Spiral Mixers carry a one-year, on-site parts and labor warranty against any defects in materials or workmanship. The one-year period begins on the date of purchase by the end user and remains in full effect provided the unit is used properly in accordance with our instructions. Any work to be performed under this warranty must be performed between the hours of 8:00 AM and 5:00 PM local time, Monday through Friday. Univex will not cover overtime charges of any kind. Please contact the Univex Warranty Service Department at 1-800-258-6358 to report warranty claims before arranging repair or attempting to return the unit to Univex Corporation.

Damages incurred in transit or incurred because of installation error, accident, alteration or misuse are not covered. Transit damage should be reported to the carrier immediately.

Univex will not be liable for any consequential, compensatory, incidental or special damages.