

Cold Food Drop-In Wells

Electric



100-CW



300-CW



500-CW

Models:

100-CW

200-CW

300-CW

400-CW

500-CW

600-CW

• **INSTALLATION**

• **OPERATION**

• **MAINTENANCE**

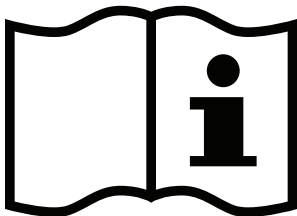

Consult
instructions
for installation
and use.



W164 N9221 Water Street • P.O. Box 450 • Menomonee Falls, Wisconsin 53052-0450 USA
PHONE: 262.251.3800 • 800.558.8744 USA/CANADA FAX: 262.251.7067 • 800.329.8744 U.S.A. ONLY
www.alto-shaam.com

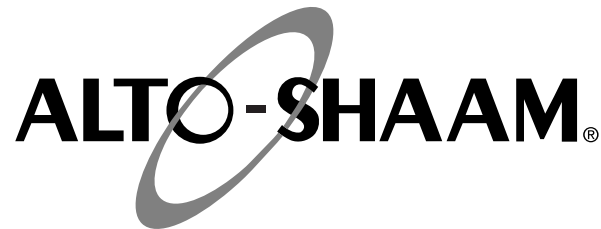

Delivery 1
Unpacking 1
Safety Procedures and Precautions 2

Installation

Installation Requirements 3
Installation and Leveling 4
Options & Accessories 5
Dimensions 5
Rough Cut Openings 8
Product/Pan Capacity 8
Louver and Vent Housing Instructions 9
Rotation of Compressor Instructions 10
Electrical Specifications 11
Electrical Connection 11
Plumbing Connection 11
Installation Checklist 12

Operating Instructions

Operating Instructions 13

Care and Cleaning

Cleaning and Preventative Maintenance 14
Protecting Stainless Steel Surfaces 14
Cleaning Agents 14
Cleaning Materials 14
Care and Cleaning 15
Sanitation 16
Preventative Maintenance 17

Service

Trouble Shooting 18
Service Parts - Exterior 19

Wire Diagrams

Always refer to the wire diagram(s) included with the unit for most current version.

Warranty

Transportation Damage and Claims Back Cover
Limited Warranty Back Cover

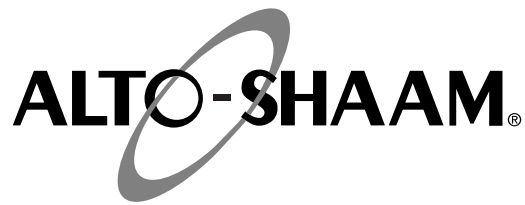

DELIVERY

This Alto-Shaam appliance has been thoroughly tested and inspected to ensure only the highest quality unit is provided. Upon receipt, check for any possible shipping damage and report it at once to the delivering carrier. *See Transportation Damage and Claims section located in this manual.*

This appliance, complete with unattached items and accessories, may have been delivered in one or more packages. Check to ensure that all standard items and options have been received with each model as ordered.

Save all the information and instructions packed with the appliance. Complete and return the warranty card to the factory as soon as possible to ensure prompt service in the event of a warranty parts and labor claim.

This manual must be read and understood by all people using or installing the equipment model. Contact the Alto-Shaam Tech Team Service Department if you have any questions concerning installation, operation, or maintenance.

NOTE: All claims for warranty must include the full model number and serial number of the unit.

UNPACKING

1. Carefully remove the appliance from the carton or crate.

NOTE: Do not discard the carton and other packaging material until you have inspected the unit for hidden damage and tested it for proper operation.

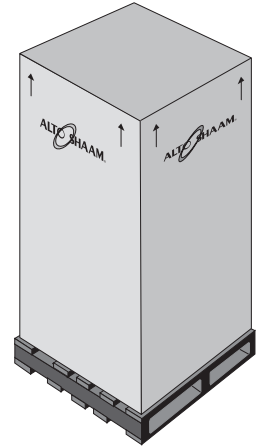

2. Read all instructions in this manual carefully before initiating the installation of this appliance.

DO NOT DISCARD THIS MANUAL.

This manual is considered to be part of the appliance and is to be provided to the owner or manager of the business or to the person responsible for training operators. *Additional manuals are available from the Alto-Shaam Tech Team Service Department.*

3. Remove all protective plastic film, packaging materials, and accessories from the appliance before connecting electrical power. Store any accessories in a convenient place for future use.

SAFETY PROCEDURES AND PRECAUTIONS

Knowledge of proper procedures is essential to the safe operation of electrically and/or gas energized equipment. In accordance with generally accepted product safety labeling guidelines for potential hazards, the following signal words and symbols may be used throughout this manual.

DANGER	
	Used to indicate the presence of a hazard that WILL cause severe personal injury, death, or substantial property damage if the warning included with this symbol is ignored.

WARNING	
	Used to indicate the presence of a hazard that CAN cause personal injury, possible death, or major property damage if the warning included with this symbol is ignored.

CAUTION	
	Used to indicate the presence of a hazard that can or will cause minor or moderate personal injury or property damage if the warning included with this symbol is ignored.

CAUTION	
Used to indicate the presence of a hazard that can or will cause minor personal injury, property damage, or a potential unsafe practice if the warning included with this symbol is ignored.	

NOTE: Used to notify personnel of installation, operation, or maintenance information that is important but not hazard related.

1. This appliance is intended to cook, hold or process foods for the purpose of human consumption. No other use for this appliance is authorized or recommended.
2. This appliance is intended for use in commercial establishments where all operators are familiar with the purpose, limitations, and associated hazards of this appliance. Operating instructions and warnings must be read and understood by all operators and users.
3. Any troubleshooting guides, component views, and parts lists included in this manual are for general reference only and are intended for use by qualified technical personnel.
4. This manual should be considered a permanent part of this appliance. This manual and all supplied instructions, diagrams, schematics, parts lists, notices, and labels must remain with the appliance if the item is sold or moved to another location.

NOTE	
	For equipment delivered for use in any location regulated by the following directive: DO NOT DISPOSE OF ELECTRICAL OR ELECTRONIC EQUIPMENT WITH OTHER MUNICIPAL WASTE.

	Used to indicate that referral to operating instructions is a mandatory action. If not followed the operator could suffer personal injury.
-------------------------------------------------------------------------------------	---------------------------------------------------------------------------------------------------------------------------------------------------

	Used to indicate that referral to operating instructions is recommended to understand operation of equipment.
-------------------------------------------------------------------------------------	----------------------------------------------------------------------------------------------------------------------

INSTALLATION

DANGER



IMPROPER INSTALLATION, ALTERATION, ADJUSTMENT, SERVICE, OR MAINTENANCE COULD RESULT IN SEVERE INJURY, DEATH, OR CAUSE PROPERTY DAMAGE.

READ THE INSTALLATION, OPERATING AND MAINTENANCE INSTRUCTIONS THOROUGHLY BEFORE INSTALLING OR SERVICING THIS EQUIPMENT.



DANGER



DO NOT store or use gasoline or other flammable vapors or liquids in the vicinity of this or any other appliance.

CAUTION



TO PREVENT PERSONAL INJURY, USE CAUTION WHEN MOVING OR LEVELING THIS APPLIANCE.

SITE INSTALLATION

The Alto-Shaam Cold Well must be installed in a location that will permit it to function for its intended purpose and to allow adequate clearance for ventilation, proper cleaning, and maintenance access.

INSTALLATION REQUIREMENTS

Counter top material must be water resistant.

Distance of 3/4" (19mm) or more between top rims of wells to ensure easy cleaning.

Must be installed level.

Must not be installed in any area where it may be directly affected by steam, grease, dripping water, high temperatures, or any other severely adverse conditions.

Must not be installed under a hood.

Avoid installation under a 4-way ceiling diffuser.

Outdoor use is not recommended.

Drain or catch basin is required.

LED lighting is recommended for overhead lighting

CLEARANCE REQUIREMENTS

4" (102mm) in front of dual air movement louver

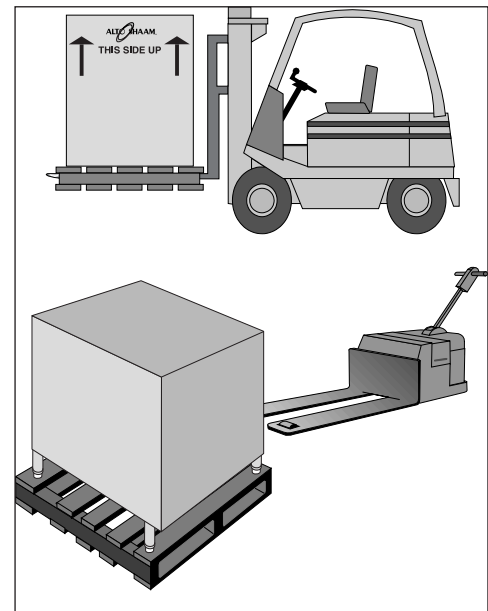

**5-Year Limited
Warranty on
self-contained
compressor**

Effective from date of shipment. (EXCLUDES LABOR)

INSTALLATION

SITE INSTALLATION

1. The cold well must be installed on a stable and level surface - free of vibration and suitably strong enough to support the combined weights of the unit plus the maximum product load weight.
2. **DO NOT** install this appliance in any area where it may be affected by any adverse conditions. Avoid placing the unit in direct sunlight, near heat generating equipment such as ovens, ranges, heaters, fryers, steam kettles, dripping water, high temperatures, or any other severely adverse conditions. Avoid locating in an unheated room or where the room temperature may drop below 55°F (13°C) or above 86°F (30°C).
3. Once the drop in unit is installed into the counter it can be secured to the counter top by using the brackets supplied.
 - a. Locate square openings on exterior body of drop unit. Insert securing bracket as shown. Tighten screw to anchor the unit tightly to cabinet top.
 - b. Seal top flange to the counter top by using food grade silicone sealant.
4. The air cooled self contained units require a sufficient amount of cool clean air. The mechanical housing (except on 100-CW appliances) can be rotated so that the condenser intake air can be in direct line with the cabinet fresh air opening.
 - a. Loosen wings nuts located under cold pan body and rotate carriage to desired location.
 - b. Tighten wing nuts when rotation is complete.
 - c. Loosen wing nuts on each side of condenser shroud and extend to fresh air opening.
 - d. Tighten wing nuts on each side of condenser shroud.

Cross ventilation in the cabinet is recommended to maintain ambient temperature 86°F (30°C) or less.
5. **DO NOT** store or use any flammable liquids or allow flammable vapors in the vicinity of this appliance or any other appliance.
6. This appliance must be kept free and clear of any combustible materials.

LEVELING

The cold well should be leveled before the electrical supply is connected. Level the appliance from side-to-side and front-to-back with the use of a spirit level.

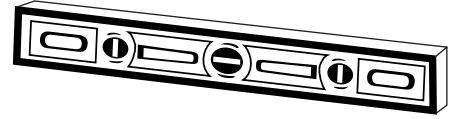

NOTE

It is important to apply a food grade silicone underneath the decor flange to seal flange to the counter top.

INSTALLATION

DIMENSIONS

100-CW

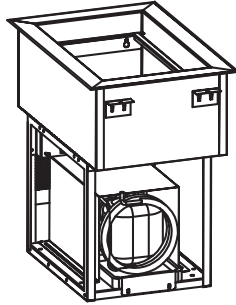
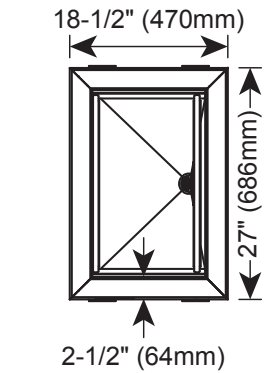

OPTIONS AND ACCESSORIES

12" (305mm) Half Size / Third-Size Divider Bars

1014395

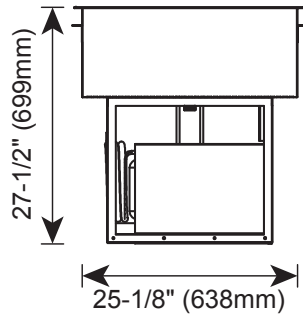
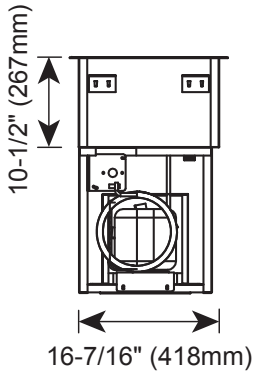

200-CW

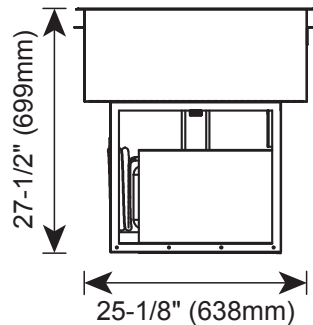
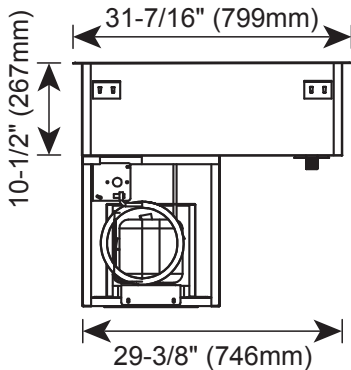
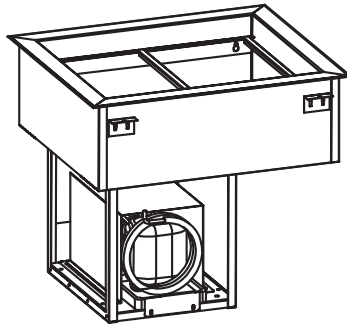
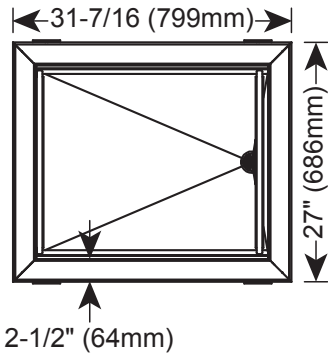

INSTALLATION

DIMENSIONS

300-CW

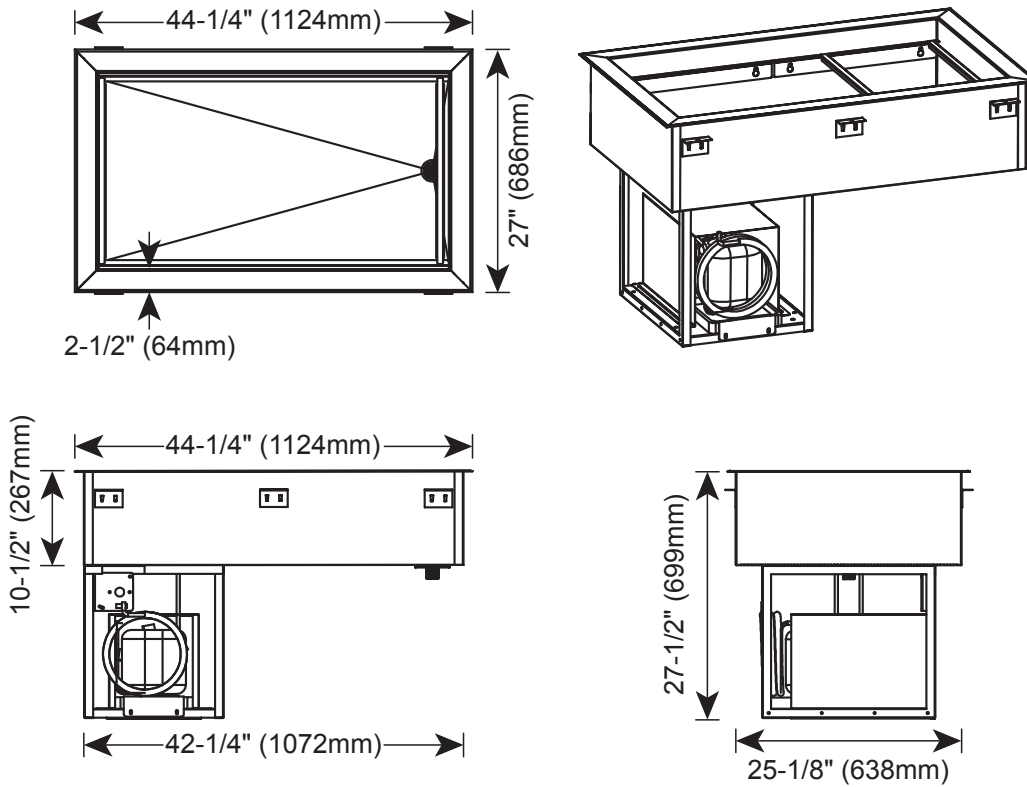

400-CW

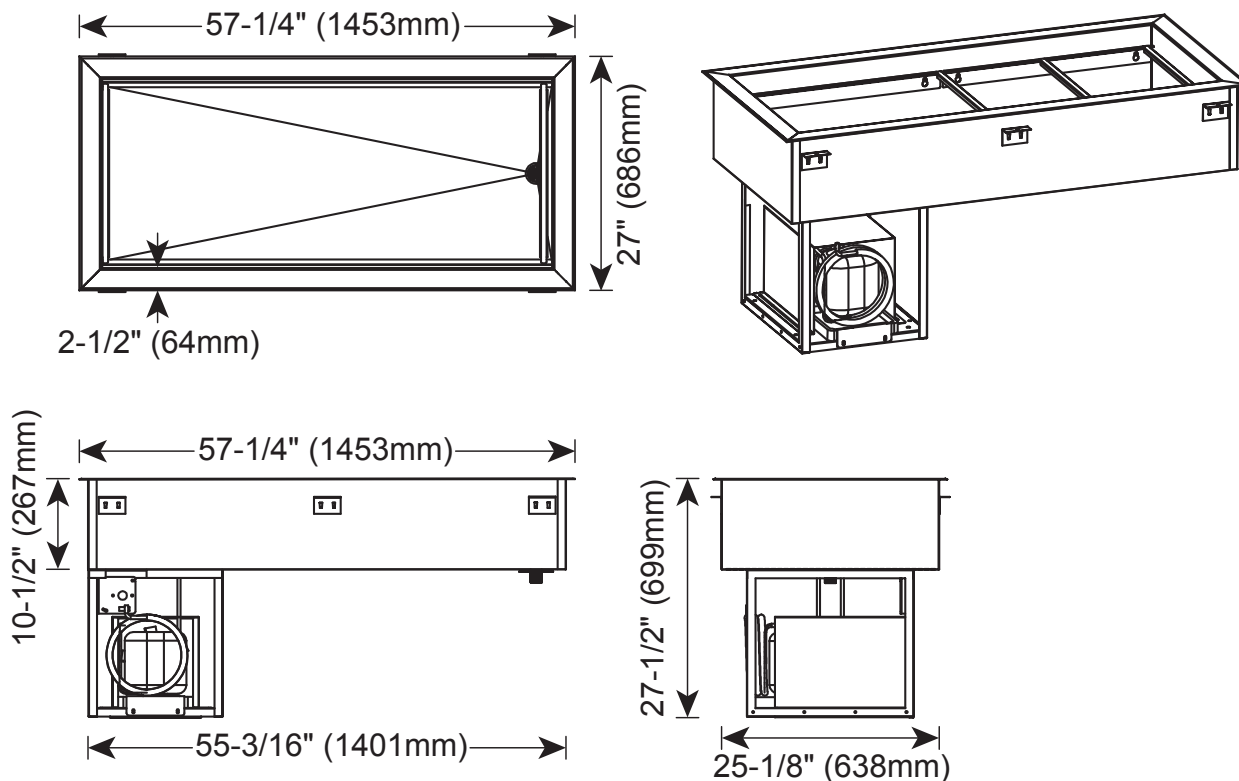

INSTALLATION

DIMENSIONS

500-CW

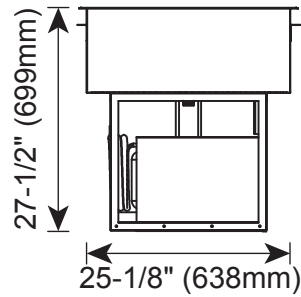
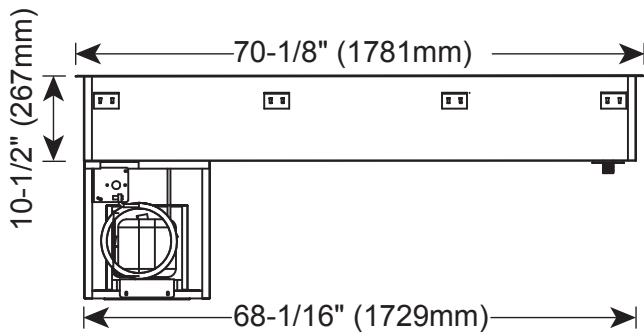
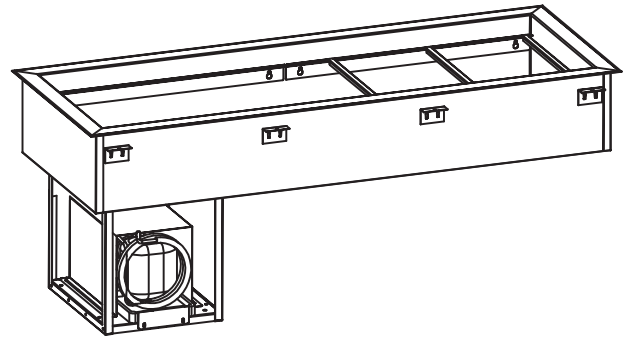
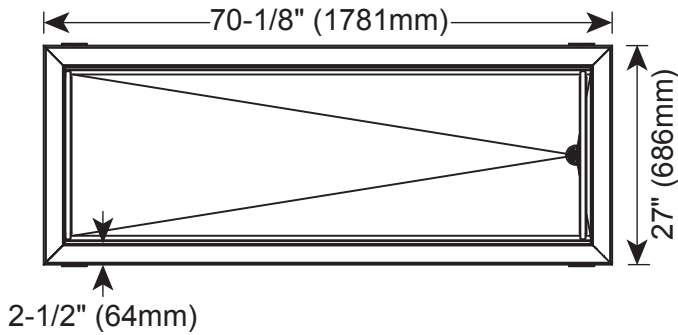

600-CW

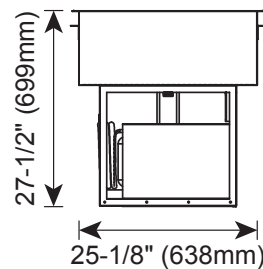
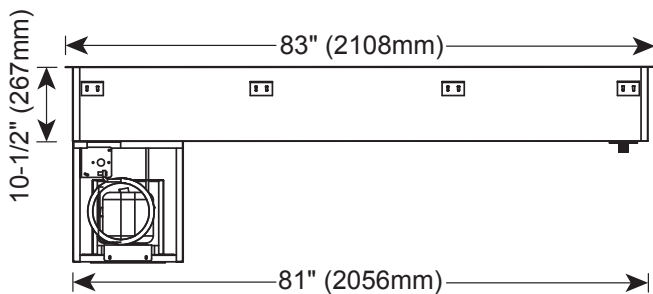
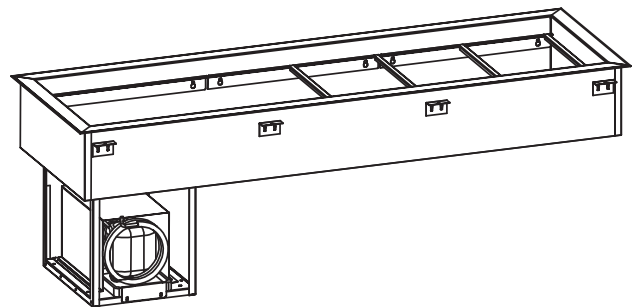
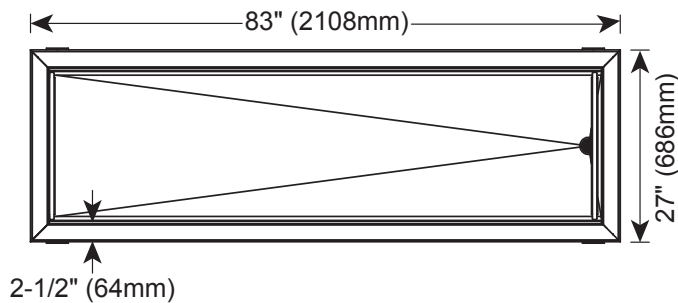

INSTALLATION

ROUGH CUT OPENINGS

MODEL	COUNTER TOP OPENING	AIR LOUVER OPENING
100-CW ONE PAN	16-7/8" L x 25-1/2" W (429mm x 648mm)	21" H x 16" W (533mm x 406mm)
200-CW TWO PAN	29-7/8" L x 25-1/2" W (759mm x 648mm)	21" H x 16" W (533mm x 406mm)
300-CW THREE PAN	42-3/4" L x 25-1/2" W (1085mm x 648mm)	21" H x 16" W (533mm x 406mm)
400-CW FOUR PAN	55-5/8" L x 25-1/2" W (572mm x 648mm)	21" H x 16" W (533mm x 406mm)
500-CW FIVE PAN	68-1/2" L x 25-1/2" W (1740mm x 648mm)	21" H x 16" W (533mm x 406mm)
600-CW SIX PAN	81-1/2" L x 25-1/2" W (2070mm x 648mm)	21" H x 16" W (533mm x 406mm)

PRODUCT/PAN CAPACITY (BASED ON 6" [176mm] DEEP PANS)

	100-CW	200-CW	300-CW	400-CW	500-CW	600-CW
Maximum Capacity	36 lb (16.3 kg)	72 lb (32.6 kg)	108 lb (48.9 kg)	144 lb (65.2 kg)	180 lb (81.5 kg)	216 lb (97.8 kg)
Maximum Volume	22 qt (21 L)	44 qt (42 L)	66 qt (62 L)	88 qt (84 L)	110 qt (105 L)	132 qt (126 L)
Full-Size Pans* - 12" x 20" x 6" GN 1/1 (325mm x 530mm x 176mm)	1	2	3	4	5	6
Half-Size Pans* - 12" x 10" x 6" GN 1/2 (325mm x 265mm x 176mm)	2	4	6	8	10	12
Third-Size Pans* - 12" x 6" x 6" GN 1/3 (325mm x 176mm x 176mm)	3	6	9	12	15	18

*WILL ALSO ACCEPT 2-1/2" (65mm) DEEP PANS AND 4" (102mm) DEEP PANS

INSTALLATION

PLACEMENT DETAILS

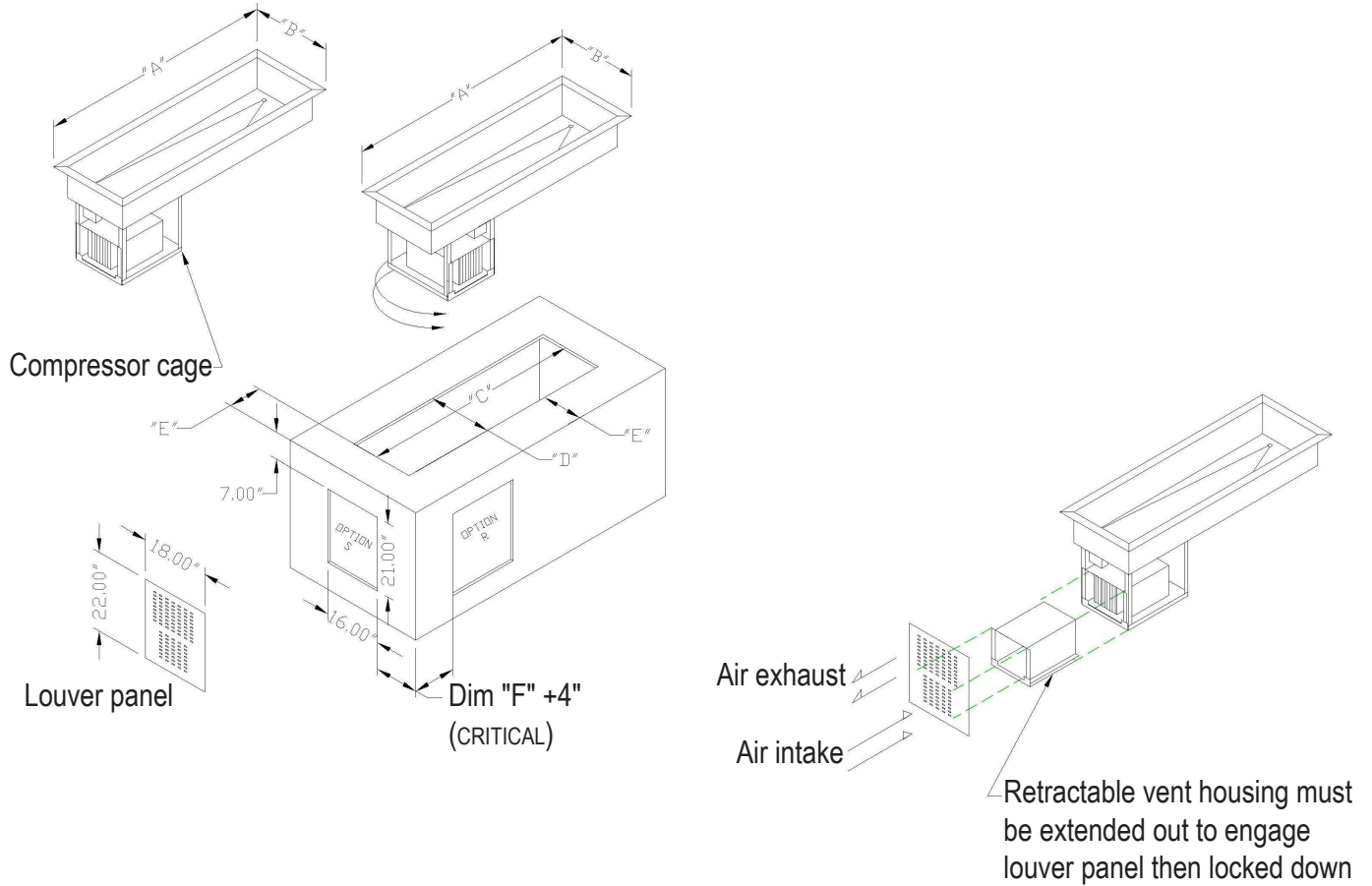

MODEL	A	B	C	D	F
100-CW ONE PAN	18-1/2" (470mm)	27" (686mm)	16-7/8" (429mm)	25-1/2" (648mm)	1-1/2" – 7-1/2" (38mm – 191mm)
200-CW TWO PAN	31-7/16" (799mm)	27" (686mm)	29-7/8" (759mm)	25-1/2" (648mm)	1-1/2" – 7-1/2" (38mm – 191mm)
300-CW THREE PAN	44-1/4" (1124mm)	27" (686mm)	42-3/4" (1085mm)	25-1/2" (648mm)	1-1/2" – 7-1/2" (38mm – 191mm)
400-CW FOUR PAN	57-1/4" (1453mm)	27" (686mm)	55-5/8" (572mm)	25-1/2" (648mm)	1-1/2" – 7-1/2" (38mm – 191mm)
500-CW FIVE PAN	70-1/8" (1781mm)	27" (686mm)	68-1/2" (1740mm)	25-1/2" (648mm)	1-1/2" – 7-1/2" (38mm – 191mm)
600-CW SIX PAN	83" (2108mm)	27" (686mm)	81-1/2" (2070mm)	25-1/2" (648mm)	1-1/2" – 7-1/2" (38mm – 191mm)

INSTALLATION

PLACEMENT DETAILS

Illustration 1

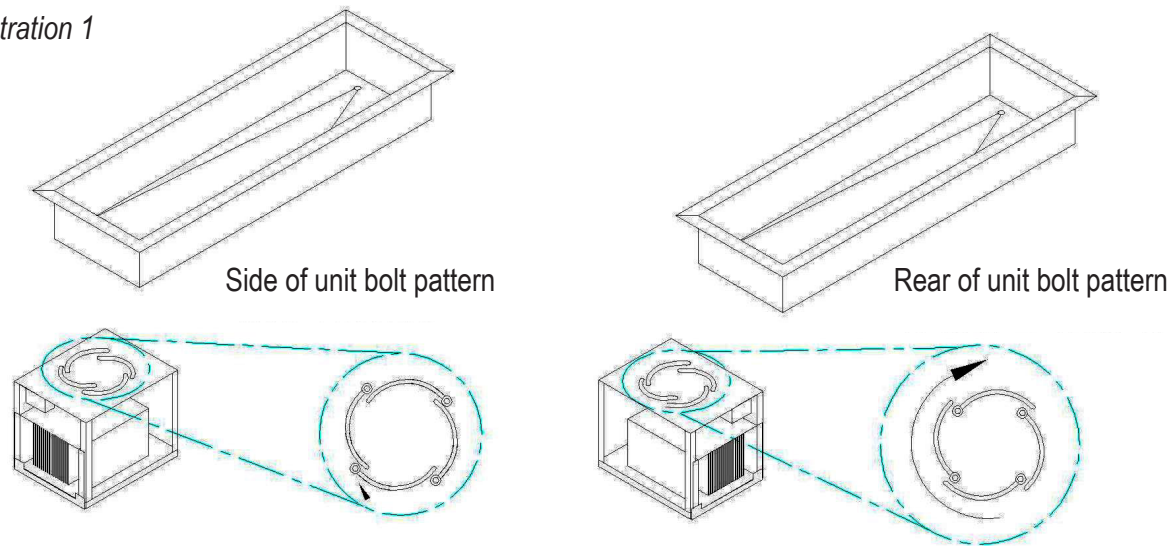
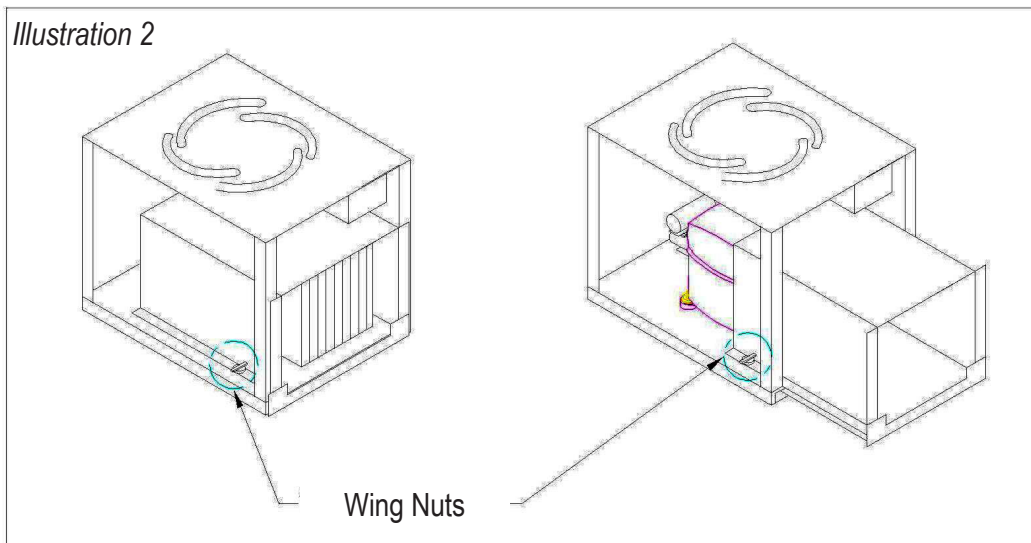

Illustration 2



TO ROTATE COMPRESSOR (*illustration 1*), loosen 4 mounting bolts on the top of the compressor cage 1 and 1/2 turns. Hold compressor cage by the frame and rotate 90° to desired position. Retighten bolts.

TO EXTEND VENT HOUSING (*illustration 2*), remove louver and loosen wing nuts located on the side of housing. Extend the housing until it engages with the louvered opening. Finger tighten wing nuts. Reinstall louver.

INSTALLATION

ELECTRICAL CONNECTION

ELECTRICAL					
VOLTAGE	PHASE	CYCLE/HZ	AMPS	kW	PLUG CONFIG.
115	1	60	5.0	.6	 NEMA 5-15P 15A-125V PLUG 9' (229mm) LONG CORD

1. An identification tag is permanently mounted on the front control panel of the appliance.
2. This appliance is equipped with a three-prong grounding plug. For your protection against shock hazard this appliance should be plugged directly into a properly grounded three-prong receptacle. Do not cut or remove the grounding prong from this plug. Plug the unit into a properly grounded receptacle **ONLY**, positioning the unit so that the plug is easily accessible in case of an emergency. Arcing will occur when connecting or disconnecting the unit unless all controls are in the "OFF" position.
3. Proper receptacle or outlet configuration or permanent wiring for this unit must be installed by a licensed electrician in accordance with applicable local electrical codes.
4. It is important that a voltage reading be made at the compressor motor electrical connections while the unit is in operation to verify that the correct voltage required by the appliance is being supplied. Low or high voltage can detrimentally affect operation and void the warranty.
5. The cold well unit should have its own dedicated line. Condensing units are designed to operate with a voltage fluctuation of plus or minus 10% of the voltage indicated on the unit data tag. Burn out of a condensing unit due to exceeding voltage limits will void the warranty.



DANGER



ENSURE POWER SOURCE MATCHES VOLTAGE IDENTIFIED ON APPLIANCE RATING TAG.





DANGER



ELECTRICAL CONNECTIONS MUST BE MADE BY A QUALIFIED SERVICE TECHNICIAN IN ACCORDANCE WITH APPLICABLE ELECTRICAL CODES.

DANGER



To avoid electrical shock, this appliance **MUST be adequately grounded in accordance with local electrical codes or, in the absence of local codes, with the current edition of the National Electrical Code ANSI/NFPA No. 70. In Canada, all electrical connections are to be made in accordance with CSA C22.1, Canadian Electrical Code Part 1 or local codes.**

PLUMBING CONNECTION

1. Drains must be plumbed to all applicable local code requirements.
2. Moisture collecting from improper drainage can create a slippery surface on the floor and a hazard to employees.



INSTALLATION CHECKLIST

PRIOR TO START-UP
Locate nameplate and record the serial number. It will be necessary when ordering replacement parts or requesting warranty service.
Follow cut out dimension provided for specific models to properly size the opening for your drop in.
Condenser coil must be facing a ventilated opening in the cabinet.
Check cord and plug of unit to assure no damage has occurred to these components.
Assure all refrigeration lines are clear of obstruction before, during, and after being installed into the counter.
Check all sheet metal surrounding the mechanical compartment to assure no damage has occurred in these areas.
The cold well should have its own dedicated electrical supply line.
Plumbing connections have been made.
Plug in unit and turn ON main on/off power switch.
Allow unit time to cool down to temperature. A layer of frost will form and remain around the inside perimeter of the rail.
Confirm that the unit is holding temperature. Set control to desired temperature for your particular ambient and altitude.

NOTE: Failure to follow installation guidelines and recommendations may void the warranty on your unit.

OPERATING INSTRUCTIONS

1. DO NOT ADD WATER TO COLD WELL

Alto-Shaam cold wells do not require the addition of water. **Adding water is not recommended** since water will accelerate the deterioration of the product and may damage the unit voiding the warranty.

2. PLACE PAN DIVIDERS AND EMPTY PANS IN THE WELLS

NOTE: No matter what type of pan configuration chosen, pan separator bars or divider bars must be used to close all gaps between pans, and all gaps between the pans and the edges of the wells. If these gaps are not closed, cold will escape, distribution will be uneven, and uniform temperature will be difficult to maintain.

This is a **VERY** important requirement to follow whenever this appliance is in use.

3. PRESS THE "ON" SWITCH AND BEGIN TO PRECHILL THE COLD WELL

The cold temperature control is preset at the factory. Due to varying conditions (i.e. elevation, food product, type of operation, etc.)

adjustments can be made (within limits) by turning the control dial until the desired temperature is reached. Please allow 24 hours

between adjustments. The control knob is located on the unit base by the compressor. Turning the knob clockwise will result in increased cooling. Keep the arrow on the knob pointed within the green arc. Turning it clockwise beyond the green can result in freeze-up, while turning it counterclockwise beyond the green arc will shut the compressor off.



NOTE: If your cold pan temperature remains too warm and your temperature control is at the maximum setting, please contact your service technician.

The unit should be pre chilled for a minimum of **30 minutes** before loading the unit with chilled food. If the unit is started at the full off position, **30-45 minutes** may be necessary for unit to cool down.

4. LOAD CHILLED FOODS INTO THE APPLIANCE

After pre chilling, place cold foods into the pre chilled pans located in the appliance or exchange the pans with pre-filled product pans. This appliance is designed for the purpose of cold food holding. *Product entering the cold pan must be at 40°F (4°C) or less.*

All pan divider bars required must be utilized at all times with the pan configuration chosen. Before loading food into the unit, use a pocket-type thermometer to make certain all products are within the cold safe zone with an internal temperature of 36° to 40°F (2° to 4°C).

5. CHECK FOOD TEMPERATURES

After all products are loaded into the unit, periodically use a pocket thermometer to check each item to make certain the correct temperatures are being maintained. Proper temperature range is between a minimum of 36° to 40°F (2° to 4°C).

6. SERVE FRESH, COLD FOOD

Keep cold foods looking fresh. Occasionally stir or rotate food as needed. Wipe spills immediately to ensure maximum eye appeal and to ease end of day cleanup.

7. EVENING SHUTDOWN

Remove product at the end of the day's preparation. Turn off the cold well with the switch located on the base by the compressor. Cleaning may be performed once the frost has melted off the rail surface.

CLEANING AND PREVENTATIVE MAINTENANCE

PROTECTING STAINLESS STEEL SURFACES



It is important to guard against corrosion in the care of stainless steel surfaces. Harsh, corrosive, or inappropriate chemicals can completely destroy the protective surface layer of stainless steel. Abrasive

pads, steel wool, or metal implements will abrade surfaces causing damage to this protective coating and will eventually result in areas of corrosion. Even water, particularly hard water that contains high to moderate concentrations of chloride, will cause oxidation and pitting that result in rust and corrosion. In addition, many acidic foods spilled and left to remain on metal surfaces are contributing factors that will corrode surfaces.





Proper cleaning agents, materials, and methods are vital to maintaining the appearance and life of this appliance. Spilled foods should be removed and the area wiped as soon as possible but at the very least, a minimum of once a day. Always thoroughly rinse surfaces after using a cleaning agent and wipe standing water as quickly as possible after rinsing.

CLEANING AGENTS

Use non-abrasive cleaning products designed for use on stainless steel surfaces. Cleaning agents must be chloride-free compounds and must not contain quaternary salts. Never use hydrochloric acid (muriatic acid) on stainless steel surfaces. Always use the proper cleaning agent at the manufacturer's recommended strength. Contact your local cleaning supplier for product recommendations.

CLEANING MATERIALS

The cleaning function can usually be accomplished with the proper cleaning agent and a soft, clean cloth. When more aggressive methods must be employed, use a non-abrasive scouring pad on difficult areas and make certain to scrub with the visible grain of surface metal to avoid surface scratches. Never use wire brushes, metal scouring pads, or scrapers to remove food residue.

 CAUTION	
 NO SCRAPERS	TO PROTECT STAINLESS STEEL SURFACES, COMPLETELY AVOID THE USE OF ABRASIVE CLEANING COMPOUNDS, CHLORIDE BASED CLEANERS, OR CLEANERS CONTAINING QUATERNARY SALTS. NEVER USE HYDROCHLORIC ACID (MURIATIC ACID) ON STAINLESS STEEL. NEVER USE WIRE BRUSHES, METAL SCOURING PADS OR SCRAPERS.
 NO WIRE BRUSHES	
 NO STEEL PADS	

CARE AND CLEANING



The cleanliness and appearance of this appliance will contribute considerably to operating efficiency and savory, appetizing food. Good equipment kept clean works better and lasts longer.



DANGER



DISCONNECT UNIT FROM POWER SOURCE BEFORE CLEANING OR SERVICING.

NOTE: Always allow the frost to melt off the rail of the appliance before cleaning.

CLEAN THE APPLIANCE DAILY.

INTERIOR:

1. Disconnect appliance from the power source. Let unit begin to return to ambient temperature.
2. After the frost has melted off the rail of the appliance, remove all detachable items such as pans and divider bars. Clean these items separately.
3. Drain water from the wells daily.
4. Remove any food scraps.
5. Wipe the interior metal surfaces with a paper towel to remove any remaining food debris.
6. Clean interior with a damp cloth or sponge and any good commercial detergent at the recommended strength.
7. For dried-on food deposits, use a non-caustic and non-toxic commercial oven cleaner appropriate for the interior surface. Follow the product manufacturer's instructions carefully for the use of this product. Any commercial oven cleaner must be approved for use on food contact areas.
8. Rinse surfaces by wiping with a clean cloth or sponge and clean warm water.
9. Remove excess water with a sponge and wipe dry with a clean cloth or air dry. Leave area open until interior is completely dry. Replace divider bars and pans.
10. Interior can be wiped with a sanitizing solution after cleaning and rinsing. This solution must be approved for use on stainless steel food contact surfaces.

DO NOT USE ABRASIVE CLEANING COMPOUNDS.

Always follow appropriate state or local health (hygiene) regulations regarding all applicable cleaning and sanitation requirements for food service equipment.

DANGER



AT NO TIME SHOULD THE INTERIOR OR EXTERIOR BE STEAM CLEANED, HOSED DOWN, OR FLOODED WITH WATER OR LIQUID SOLUTION OF ANY KIND. DO NOT USE WATER JET TO CLEAN.



SEVERE DAMAGE OR ELECTRICAL HAZARD COULD RESULT.

WARRANTY BECOMES VOID IF APPLIANCE IS FLOODED

NOTE: Completely avoid the use of abrasive cleaning compounds, chloride-based cleaners, or cleaners containing quaternary salts. To protect metal finish on stainless steel, never use hydrochloric acid (muriatic acid).



SANITATION

Food flavor and aroma are usually so closely related that it is difficult, if not impossible, to separate them. There is also an important, inseparable relationship between cleanliness and food flavor. Cleanliness, top operating efficiency, and appearance of equipment contribute considerably to savory, appetizing foods. Good equipment that is kept clean, works better and lasts longer.

Most food imparts its own particular aroma and many foods also absorb existing odors. Unfortunately, during this absorption there is not distinction between GOOD and BAD odors. The majority of objectionable flavors and odors troubling food service operations are caused by bacteria growth. Sourness, rancidity, mustiness, stale or other OFF flavors are usually the result of germ activity.

The easiest way to insure full, natural food flavor is through comprehensive cleanliness. This means good control of both visible soil (dirt) and invisible soil (germs). A thorough approach to sanitation will provide essential cleanliness. It will assure an attractive appearance of equipment, along with maximum efficiency and utility. More importantly, a good sanitation program provides one of the key elements in the prevention of food-borne illnesses.

A controlled holding environment for prepared foods is just one of the important factors involved in the prevention of food-borne illnesses. Temperature monitoring and control during receiving, storage, preparation, and the service of foods are of equal importance.

The most accurate method of measuring safe temperatures of both hot and cold foods is by internal product temperature. A quality thermometer is an effective tool for this purpose, and should be routinely used on all products that require holding at a specific temperature.

A comprehensive sanitation program should focus on the training of staff in basic sanitation procedures. This includes personal hygiene, proper handling of raw foods, cooking to a safe internal product temperature, and the routine monitoring of internal temperatures from receiving through service.

Most food-borne illnesses can be prevented through proper temperature control and a comprehensive program of sanitation. Both these factors are important to build quality service as the foundation of customer satisfaction. Safe food handling practices to prevent food-borne illness is of critical importance to the health and safety of your customers.

HACCP, an acronym for Hazard Analysis (at) Critical Control Points, is a quality control program of operating procedures to assure food integrity, quality, and safety. Taking steps necessary to augment food safety practices is both cost effective and relatively simple. While HACCP guidelines go far beyond the scope of this manual, additional information is available by contacting:

**CENTER FOR FOOD SAFETY AND APPLIED
NUTRITION FOOD AND DRUG ADMINISTRATION
1-888-SAFEFOOD**

INTERNAL FOOD PRODUCT TEMPERATURES		
HOT FOODS		
DANGER ZONE	40° TO 140°F	(4° TO 60°C)
CRITICAL ZONE	70° TO 120°F	(21° TO 49°C)
SAFE ZONE	140° TO 165°F	(60° TO 74°C)
COLD FOODS		
DANGER ZONE	ABOVE 40°F	(ABOVE 4°C)
SAFE ZONE	36° TO 40°F	(2° TO 4°C)
FROZEN FOODS		
DANGER ZONE	ABOVE 32°F	(ABOVE 0°C)
CRITICAL ZONE	0° TO 32°F	(-18° TO 0°C)
SAFE ZONE	0°F or below	(-18°C or below)

PREVENTATIVE MAINTENANCE

ALTO-SHAAM STRONGLY SUGGESTS A PREVENTATIVE MAINTENANCE PROGRAM

which would include the following *monthly* procedures:

TASK	WHY	HOW
Clean all condenser coils	Condenser coils are a critical component in the life of the compressor and must remain clean to assure proper air flow and heat transfer.	Clean the condenser coils with coil cleaner and/or a vacuum, cleaner and brush.
		Brush coil in direction of fins, (usually vertical) to avoid damage or restrict air from passing through the condenser.
Clean fan blade on the condensing unit	Fan blade can collect dust and transfer that dust into the condenser coils.	Clean the fan blade with a vacuum, cleaner and brush.

NOTE: Do not use sharp utensils.

Use of any filter over the condenser coil may result in poor performance of the equipment.

The factory does not recommend the use of any auxiliary filter. Any failures of the unit as a result of an auxiliary filter will not be covered under warranty.



**5-Year Limited
Warranty on
self-contained
compressor**

Effective from date of
shipment. (EXCLUDES LABOR)

TROUBLE SHOOTING

PROBLEM	POSSIBLE CAUSE	REMEDY
UNIT WILL NOT COOL	Thermostat off	Turn thermostat on
	Unit unplugged	Plug in appliance
	Circuit breaker tripped	Replace breaker
	Unknown problem	Call service agency
UNIT DOESN'T RUN	No power to unit	Plug in appliance (check power switch)
	Temperature control turned off	Check temperature control
	Temperature control faulty	Test temperature control
	Compressor overheated	Clean condenser coil
	Condenser fan faulty	Service condenser fan
	Overload protector faulty	Test overload
	Compressor relay faulty	Test relay
	Compressor faulty	Call service agency
UNIT SHORT CYCLES	Condenser coil dirty	Clean coil
	Condenser fan faulty	Service fan and motor
	Compressor faulty	Call service agency
	Overload repeatedly tripping	Check outlet voltage
UNIT RUNS CONSTANTLY	Condenser coil dirty	Clean coil
	Condenser fan faulty	Service condenser motor
	Low on refrigerant	Call service agency
UNIT TOO COLD	Temperature control set too low	Adjust control to raise setting
	Temperature control faulty	Test control
UNIT NOISY	Compressor mountings loose or hardened	Tighten or replace compressor mountings
	Condenser fan damaged or hitting fan shroud	Inspect condenser fan



SERVICE

EXTERIOR SERVICE VIEW (400-CW SHOWN)

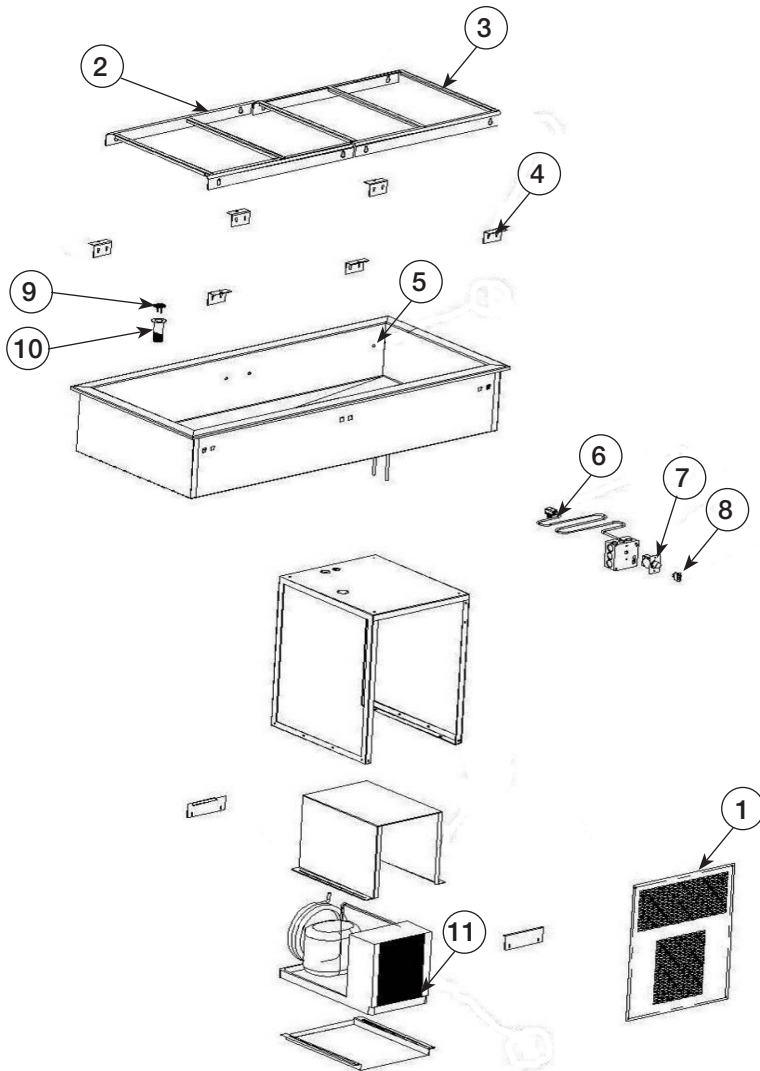

Part numbers and drawings are subject to change without notice.

ITEM	DESCRIPTION	PART NO.
1	Panel, Louvered Flat 18" x 22"	PE-35919
2	Clips, Pan Rail, CW-100	CL-35911
	Clips, Pan Rail, CW-200	CL-35912
	Clips, Pan Rail, CW-300	CL-35913
	Clips, Pan Rail, CW-400	CL-35914
	Clips, Pan Rail, CW-500	CL-35915
	Clips, Pan Rail, CW-600	CL-35916
3	Adapter Bar	PN-35917
4	Hold Down Clips	CL-35910
5	Pin, Key Pan Rail	PI-35908

ITEM	DESCRIPTION	PART NO.
6	Power Cord, 9' (2743mm) & Plug	CD-35920
7	Temperature Control	CC-35921
8	Rocker Switch	SW-35923
9	Drain Screen	DA-35918
10	Gate Valve, 1" Threaded	VA-35909
11	Coil, Condenser, 1/4 HP	RE-35924
*	Capillary Tube with Drier	CP-35927
*	Cord, 14 GA 18", Female	CD-35922
*	Condenser Fan Motor, Blade, and Guard Assembly	MO-35928
*	Filter Dryer	FI-35926

* NOT SHOWN

Refer to wire diagram sent with unit

Need new WD

TRANSPORTATION DAMAGE and CLAIMS



All Alto-Shaam equipment is sold F.O.B. shipping point, and when accepted by the carrier, such shipments become the property of the consignee.

Should damage occur in shipment, it is a matter between the carrier and the consignee. In such cases, the carrier is assumed to be responsible for the safe delivery of the merchandise, unless negligence can be established on the part of the shipper.

1. Make an immediate inspection while the equipment is still in the truck or immediately after it is moved to the receiving area. Do not wait until after the material is moved to a storage area.
2. Do not sign a delivery receipt or a freight bill until you have made a proper count and inspection of all merchandise received.
3. Note all damage to packages directly on the carrier's delivery receipt.
4. Make certain the driver signs this receipt. If he refuses to sign, make a notation of this refusal on the receipt.
5. If the driver refuses to allow inspection, write the following on the delivery receipt:
Driver refuses to allow inspection of containers for visible damage.
6. Telephone the carrier's office immediately upon finding damage, and request an inspection. Mail a written confirmation of the time, date, and the person called.
7. Save any packages and packing material for further inspection by the carrier.
8. Promptly file a written claim with the carrier and attach copies of all supporting paperwork.

We will continue our policy of assisting our customers in collecting claims which have been properly filed and actively pursued. We cannot, however, file any damage claims for you, assume the responsibility of any claims, or accept deductions in payment for such claims.

LIMITED WARRANTY

Alto-Shaam, Inc. warrants to the original purchaser only that any original part that is found to be defective in material or workmanship will, at Alto-Shaam's option, subject to provisions hereinafter stated, be replaced with a new or rebuilt part.

The original parts warranty period is as follows:

For the refrigeration compressor on Alto-Shaam Quickchillers™, five (5) years from the date of installation of appliance.

For the heating element on Halo Heat® cooking and holding ovens, as long as the original purchaser owns the oven. This excludes holding only equipment.

For all other original parts, one (1) year from the date of installation of appliance or fifteen (15) months from the shipping date, whichever occurs first.

The labor warranty period is one (1) year from the date of installation or fifteen (15) months from the shipping date, whichever occurs first.

Alto-Shaam will bear normal labor charges performed during standard business hours, excluding overtime, holiday rates or any additional fees.

To be valid, a warranty claim must be asserted during the applicable warranty period. This warranty is not transferable.

THIS WARRANTY DOES NOT APPLY TO:

1. Calibration.
2. Replacement of light bulbs, door gaskets, and/or the replacement of glass due to damage of any kind.
3. Equipment damage caused by accident, shipping, improper installation or alteration.
4. Equipment used under conditions of abuse, misuse, carelessness or abnormal conditions, including but not limited to, equipment subjected to harsh or inappropriate chemicals, including but not limited to, compounds containing chloride or quaternary salts, poor water quality, or equipment with missing or altered serial numbers.
5. Damage incurred as a direct result of poor water quality, inadequate maintenance of steam generators and/or surfaces affected by water quality. Water quality and required maintenance of steam generating equipment is the responsibility of the owner/operator.
6. Damage caused by use of any cleaning agent other than Alto-Shaam's Combitherm® Cleaner, including but not limited to damage due to chlorine or other harmful chemicals. **Use of Alto-Shaam's Combitherm® Cleaner on Combitherm® ovens is highly recommended.**
7. Any losses or damage resulting from malfunction, including loss of product, food product, revenue, or consequential or incidental damages of any kind.
8. Equipment modified in any manner from original model, substitution of parts other than factory authorized parts, removal of any parts including legs, or addition of any parts.

This warranty is exclusive and is in lieu of all other warranties, express or implied, including the implied warranties of merchantability and fitness for a particular purpose. In no event shall Alto-Shaam be liable for loss of use, loss of revenue or profit, or loss of product, or for any indirect, special, incidental, or consequential damages. No person except an officer of Alto-Shaam, Inc. is authorized to modify this warranty or to incur on behalf of Alto-Shaam any other obligation or liability in connection with Alto-Shaam equipment.



Effective November 1, 2012

RECORD THE MODEL AND SERIAL NUMBER OF THE APPLIANCE FOR EASY REFERENCE.

ALWAYS REFER TO BOTH MODEL AND SERIAL NUMBER IN ANY CONTACT WITH ALTO-SHAAM REGARDING THIS APPLIANCE.

Model: _____ Date Installed: _____
Voltage: _____ Purchased From: _____
Serial Number: _____

W164 N9221 Water Street • P.O. Box 450 • Menomonee Falls, Wisconsin 53052-0450 • U.S.A.
PHONE: 262.251.3800 • 800.558-8744 USA/CANADA FAX: 262.251.7067 • 800.329.8744 U.S.A. ONLY

www.alto-shaam.com

PRINTED IN U.S.A.