



Installation, Operation, and Maintenance Instructions

Deck Oven

Model: DO36 and DO36L

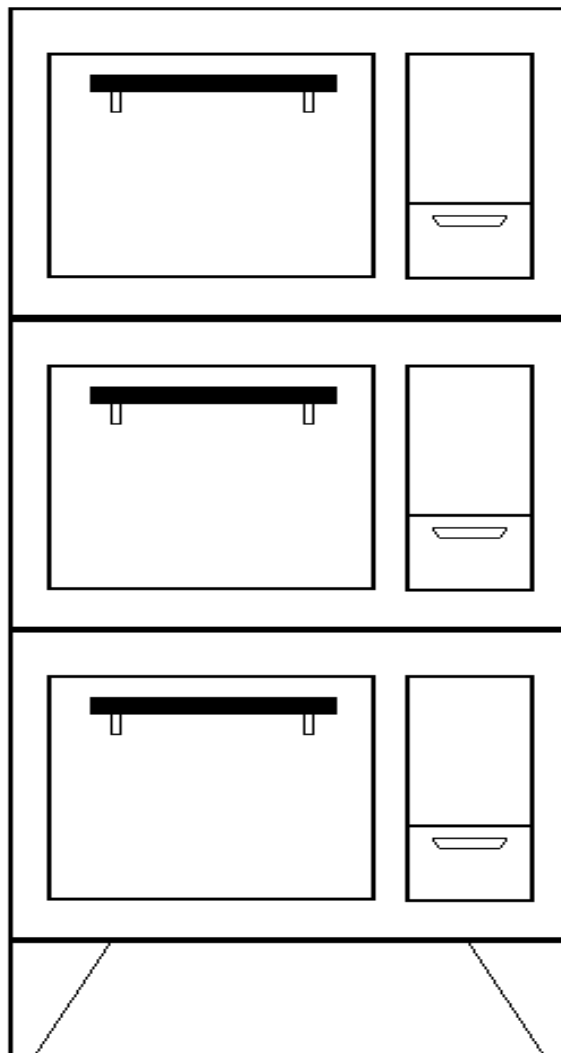

TABLE OF CONTENTS

TABLE OF CONTENTS	1
INTRODUCTION	
DESCRIPTION.....	1
FEATURES	1
SAFETY PRECAUTIONS AND WARNINGS	2
INSTALLATION	
RECEIVING AND UNCRATING	3
INSTALLING THE LEGS	3
CLEARANCES.....	3
DECK OVEN ASSEMBLY	3
STACKING THE OVENS.....	3
ELECTRICAL CONNECTION.....	4
INTERCONNECTING THE OVENS	4
OVEN PHASING	5
LOAD REQUIREMENTS	5
RANGE ASSEMBLY	6
INSTALLATION ON OVEN BASE	6
ELECTRICAL CONNECTION.....	6
PHASING RANGE ASSEMBLY.....	7
LOAD REQUIREMENTS	7
OPERATION	
INITIAL START-UP	8
NORMAL OPERATION	8
PREHEATING.....	8
OVEN RACK.....	8
CONTROL PANEL.....	9
3-HEAT SWITCHES	9
PAN PLACEMENT.....	10
VENT CONTROL.....	10
TIMER	10
PRODUCTIVE MAINTENANCE	
CLEANING.....	11
THERMOSTAT CALIBRATION	11
CALIBRATION CHECK PROCEDURE	11
CALIBRATION ADJUSTMENT	12
INSTALLATION TROUBLESHOOTING GUIDE	13
OVEN PARTS LIST	14
DECK OVEN WIRING SERIES	15
WIRING DIAGRAM	
208/240V	16
240V.....	17

INTRODUCTION

This manual contains the necessary information to install, operate, and maintain the Lang DO36L Series Electric Deck Oven.

DESCRIPTION

The DO36 Series Deck Oven is designed as a single pan all purpose baking and roasting oven. The oven can be stacked with other 36 bake ovens, stacked with a F6 Convection Oven, or assembled with a three section Cook Top to create a range with any top configuration.

FEATURES

The oven cavity is large enough to accept a single full size sheet pan. The pan can be placed on the pebble oven deck or raised off of the deck and placed in the middle of the cavity on a rack, supplied with the oven.

The heating elements are located above the product and below the oven deck.

They are controlled by a thermostat with an operational range of 150°F to 550°F and two Hi-Medium-Low (3-Heat) switches.

The oven features a 1 hour timer and oven cavity vent as standard equipment.

The oven door is a self closing pull down type that when fully open is strong enough to act as a loading platform for the oven.

The oven front is a high quality stainless steel; the oven sides, top, and back are baked enamel or optional stainless steel. The oven cavity is a durable aluminized finish.

SAFETY PRECAUTIONS AND WARNINGS

DANGER

MAKE SURE THE MAIN POWER SUPPLY IS TURNED OFF AT THE SOURCE PRIOR TO CONNECTING POWER TO THE APPLIANCE.

Disconnect the appliance from power before attempting any repair

The following clearances to combustible surfaces must be maintained.

4 inches to sides

3 inches to back

Make sure the wire leads that supply electricity to the cook top or upper oven decks are not pinched between the oven and range top or between the decks.

Be sure the power supply voltage matches the voltage specified on the data plate.

This appliance must be phased per the wiring diagram.

Any cleaner used in the oven cavity must be labeled "Safe on Aluminum".

INSTALLATION

RECEIVING AND UNCRATING

Upon receipt of the equipment, check for freight damage, both concealed and visible. Visible damage must be noted on the freight bill at the time of delivery and signed for by the freight company's agent. Concealed loss or damage means loss or damage which does not become apparent until the merchandise has been unpacked. When concealed damage is discovered, make a written request for inspection by the carrier's agent within 15 days of the delivery date. In either case, **do not return the damaged merchandise to Star Manufacturing, file your claim with the carrier.**

Before uncrating the equipment confirm that the voltage marked on the box matches that of the building. The oven voltage must match the voltage supplied.

Place the crate as near the intended installation as possible before uncrating the equipment. The crate will help protect the equipment while it is being moved through doorways and down halls. Uncrate the oven and set as near the intended installation as practical. Save the crating materials as they may be used during the installation.

INSTALLING THE LEGS

If the oven is to be assembled as a range the legs are packaged in with the range top. If the oven is to be stacked on another oven the legs are packaged in a separate box marked "Fabricated Legs".

Place some cardboard on the floor and gently tip the oven backwards onto it.

The range legs are screwed into 4 nuts welded to the bottom of the oven. Make

sure the legs are screwed firmly into the nuts.

The stacked oven fabricated legs attach to the bottom corners of the oven with the nuts and bolts supplied with the legs.

Set the oven on the legs, push it into position, and level it using the adjusters on the bottom of the legs.

CLEARANCES

THE FOLLOWING CLEARANCES TO COMBUSTIBLE SURFACES MUST BE MAINTAINED:

- 4 INCHES TO SIDES
- 3 INCHES TO BACK

DECK OVEN ASSEMBLY

STACKING THE OVENS

If the oven is to be assembled as a range, skip this section refer to the Range Top Installation Manual.

Remove the envelope labeled "Stacking Kit" from the oven cavity.

Place some cardboard on the floor and gently tip the oven that is to be stacked backwards onto it. Install four pins from the stacking kit into the threaded holes on the side flanges of the oven bottom.

Remove the plastic plugs from the top of the oven on legs so the pins just installed in the top oven can nest into the holes.

Lift the oven that is lying on its back onto the oven on legs. Align the pins so they drop into the holes in the bottom oven.

ELECTRICAL CONNECTION

DANGER

MAKE SURE THE POWER SUPPLY TO THE APPLIANCE IS TURNED OFF BEFORE MAKING THE CONNECTION.

If the oven is to be assembled as a range, skip this section and refer to the Range Top Installation Manual.

The electrical connection is made through a 1 1/4 inch knockout in the bottom of the oven to a terminal block located behind an access door that is below the control panel.

Before connecting the oven to power check the data plate located behind the access door to confirm that the power supply wires are large enough to carry the load.

A one deck oven requires a single phase connection only; however, this does not mean the oven cannot be connected to a three phase service, simply use two lines of the three phase.

INTERCONNECTING THE OVENS

If the oven is assembled as a 2 deck model, remove the wire from one of the Stacking Kit envelopes and cut it in half.

Strip the cut ends of the wires 3/4 inch and install them into the terminal block of the top oven. Snap a 3/4 inch plastic bushing from one of the Stacking Kit envelopes into the hole in the bottom of the top oven and run the wires from the top oven through it to the terminal block in the bottom oven. Connect the top oven wires into the terminal block with the wires from the bottom oven. Refer to the wiring diagram in this manual for the correct phasing of the wires.

If the oven is assembled as a 3 deck model, remove the wires from all three Stacking Kit envelopes and cut one in half. Use the 2 full length wires to connect to the top deck and the cut wire to connect to the middle deck. Refer to the figure below or the wiring diagram in back of this manual for the correct wire grouping at the bottom oven terminal block.

OVEN PHASING

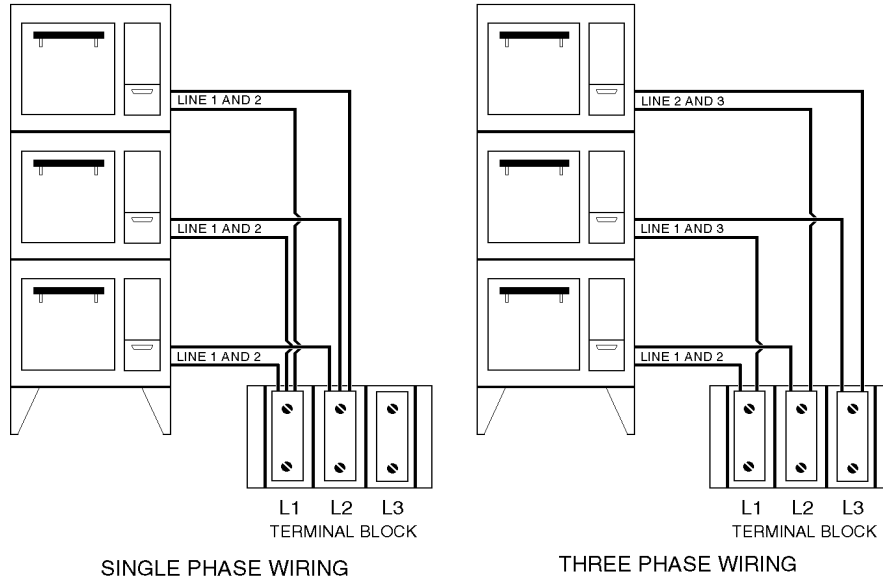

SINGLE PHASE WIRING

THREE PHASE WIRING

Power Supply	Terminal Block	OVEN		
		1ST Deck	2ND Deck	3RD Deck
Single Phase	L1	X	X	X
	L2	X	X	X
Three Phase	L1	X	X	
	L2	X		X
	L3		X	X

LOAD REQUIREMENTS

MODEL NO.	LOADING KW PER PHASE					TOTAL L Kw	THREE PHASE AMPS									SINGLE PHASE AMPS	
	L1	L2	L3	L1	L2		208 VOLT			240 VOLT			480 VOLT			208V	240V
							L1	L2	L3	L1	L2	L3	L1	L2	L3		
DO36I	6	0	0	6		6	28.8	28.8	0	25	25	0	12.5	12.5	0	28.8	25
DO36L	6	0	0	6		6	28.8	28.8	0	25	25	0	12.5	12.5	0	28.8	25
D036	6	0	0	6		6	28.8	28.8	0	25	25	0	12.5	12.5	0	28.8	25
DO362	6	0	6	12		12	50	28.8	28.8	43.3	25	25	21.7	12.5	12.5	57.7	50
D0363	6	6	6	18		18	50	50	50	43.3	43.3	43.3	21.7	21.7	21.7	86.5	75

RANGE ASSEMBLY

INSTALLATION ON OVEN BASE

Remove all the plastic plug buttons from the top of oven(s).

Lay a 2 X 4 or cardboard corner pad across the top of the oven.

Lift the range top off of the shipping skid and place it on top of the oven so that the front edge of the range top is sitting on the 2 X 4 and is elevated off of the oven top.

Feed the two groups of power supply wires through the two holes in the oven top until all the wire slack is inside the oven control compartment.

Lift the front of the range top and remove the 2 X 4.

Allow the range top to set into place so that the pins in the bottom of the range top nest into the holes in the top of the oven base.

ELECTRICAL CONNECTION

The electrical connection must be made in accordance with local codes or in the absence of local codes with NFPA No. 70 latest edition (in Canada use: CSA STD. C22.1)

Supply wire size must be large enough to carry the amperage load for the range being installed. Wire size information can be found on the range data plate.

This range can be installed on both single and three phase supplies and is shipped from the factory un-phased.

The range top wires connect into a terminal block located in the oven base control compartment.

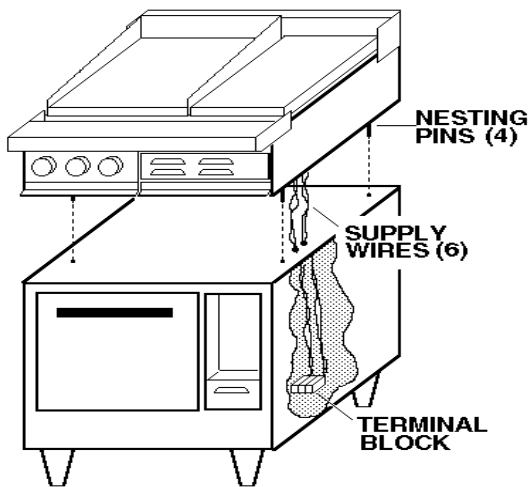

PHASING RANGE ASSEMBLY

Follow the drawings, below, to group the supply wires to match the power phase.

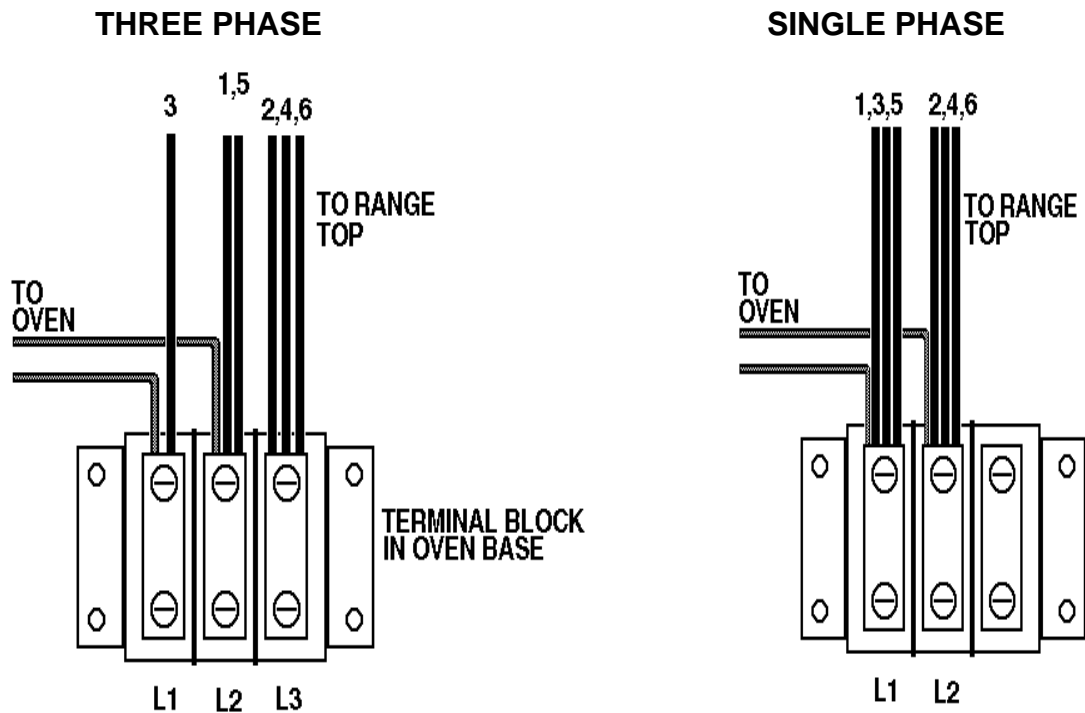

LOAD REQUIREMENTS

For proper supply wire and circuit breaker size, refer to the chart below.

Star Model Number	Lang Model Number	THREE PHASE LOADING			Total KW Conn	NOMINAL AMPS PER LINE										
		K.W. PER PHASE				THREE PHASE									SINGLE PHASE	
		L1 - L2	L2 -L3	L3 -L1		208 VOLT			240 VOLT			480 VOLT			208V	240V
						L1	L2	L3	L1	L2	L3	L1	L2	L3		
136SB	36S	6.0	10.0	5.0	21.0	45.8	66.7	62.5	39.7	57.8	54.2	19.9	28.9	27.1	101.0	87.5
N/A	72S #1	6.0	10.0	5.0	21.0	45.8	66.7	62.5	39.7	57.8	54.2	19.9	28.9	27.1	101.0	87.5
N/A	72S #2	6.0	10.0	5.0	21.0	45.8	66.7	62.5	39.7	57.8	54.2	19.9	28.9	27.1	101.0	87.5
R36C	RF21S	6.6	10.0	5.0	21.6	48.3	69.2	62.5	41.9	59.9	54.2	20.9	30.0	27.1	103.8	90.0
N/A	RF42S#1	6.6	10.0	5.0	21.6	48.3	69.2	62.5	41.9	59.9	54.2	20.9	30.0	27.1	103.8	90.0
N/A	RF42S#2	6.6	10.0	5.0	21.6	48.3	69.2	62.5	41.9	59.9	54.2	20.9	30.0	27.1	103.8	90.0
TOP ONLY		5.0	5.0	5.0	15.0	41.7	41.7	41.7	36.1	36.1	36.1	18.1	18.1	18.1	72.1	62.5

OPERATION

INITIAL START-UP

The preservatives must be cleaned off the oven front before it is heated. Wipe the oven front with a damp rag and a mild soap solution, rinse with warm water and a damp rag, and then completely dry the oven front.

Before the initial use of the oven it must be allowed to thoroughly dry the elements out. This is accomplished by setting the top and bottom oven 3-heat switches to the "Low" position and the thermostat to 350 degrees. Allow the oven to heat until all vapor and smoke has been eliminated.

Somewhere along the rising temperature curve between 250 and 350 degrees a moderate amount of smoke will issue from within the oven. Preservative oils and oil accumulated during manufacture will come off as smoke at these temperatures. Do not be alarmed.

NORMAL OPERATION

PREHEATING

The oven will not bake uniformly if not allowed to thoroughly preheat before loading the product. To compensate for the temperature loss during loading, set the oven thermostat 50 degrees over the desired cooking temperature, load the oven, then reset the thermostat to the proper temperature after closing the oven door. The oven can be preheated with the 3-Heat switches set on any position, however, the fastest preheat will be accomplished with both the switches set to the "High" position. Once the oven is at the set temperature and the product is loaded reset the 3-Heat switches to their proper setting. An indicator light, located below the oven thermostat knob, will go out once the oven has received the set temperature. Allow the oven indicator lamp to cycle on and off at least two times during the preheat.

OVEN RACK

The oven is equipped with a removable rack as standard. Baking pies, bread, or for roasting operations the rack can be placed directly on the metal deck and the pans placed on the rack. For cakes or pastries the rack can be slid into the rack supports, located about halfway up the oven sides, and the pans placed on the rack in this raised position.

CONTROL PANEL

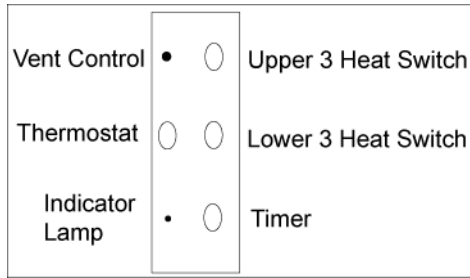

3-HEAT SWITCHES

While the oven thermostat controls the temperature, the 3-Heat switches control the amount of power from the upper and lower elements. Setting the top element 3-Heat switch to "High" will burn (or broil) the tops and setting the bottom 3-Heat switch to "Low" will not cook the bottom of most products. Set the 3-Heat switches to achieve the best uniformity between the top and bottom of the

product. Best results for baking will be accomplished with the top 3-Heat switch set to the "Low" position and the bottom 3-Heat switch set to either "Medium" or "High".

The following Temperature Switch Setting and Rack Position chart is suggested as a guide in baking the various classes of product. Be aware this chart is only a suggestion. Correct temperature, switch settings and rack positions will be arrived at through experience.

Class of product	Average Temperature	Switch Settings		Rack Position
		Top	Bottom	
Pie	375-425	Low	Medium	On Deck
Rolls	375-400	Low	High	Rack Support
Cake	350-400	Low	High	Rack Support
Pastries	325-375	Low	High	Rack Support
Bread	425-450	Low	Medium	On Deck
Roast	300-325	Low	Medium	On Deck

PAN PLACEMENT

Place the pan in the center of the oven rack for the best baking results. Keep the oven door closed as much as possible. Excessively opening the oven door will cool the front section of the oven and the products placed near the opening will bake slower.

VENT CONTROL

The oven is supplied with an oven vent control located above the thermostat dial. If cooking products with high moisture content open the vent by pulling the knob out. The moisture will be vented out the back of the oven as steam. If the

products require a moist baking environment push the vent damper closed.

TIMER

A 60 minute mechanical timer is supplied as standard equipment. To set, turn the dial until the desired time is at the top of the dial. If setting the timer for less than 10 minutes the dial must first be turned past the 10 minute mark then reset to the required time. Once the timer has timed-out it will sound a bell for about 5 seconds then automatically turn off.

PRODUCTIVE MAINTENANCE

"Productive Maintenance" is defined as a means of keeping the appliance as efficient and productive after years of service as it was when new.

CLEANING

Cleaning the appliance on a regular basis will assure years of efficient performance and maintain the gleaming appearance it has when new.

Clean the exterior of the oven using a mild soap and water solution. Rinse with clear water and a damp rag.

Do not use a pressure washer of any kind to clean the appliance exterior or interior.

CAUTION

The oven interior must be cleaned with a cleaner that states it is "Safe on Aluminum". Use of any other cleaner will severely damage the coating on the inside of the oven and it can not be repaired.

Pay particular attention around the door opening, door edges and at the bottom of the door so the door continues to close tightly. Should the paint around the door opening begin to wear off, it can be recoated using a high temperature silver paint found in any hardware store.

THERMOSTAT CALIBRATION

All thermostats are factory calibrated and are extremely reliable mechanical devices. Thermostat calibration should be attempted only when continued experience indicates inaccurate cooking temperatures and then only after the calibration of the thermostat has been thoroughly checked.

However, as the appliance becomes older the thermostat should be checked once a year in order to make minor adjustments to the calibration.

CALIBRATION CHECK PROCEDURE

Locate an oven thermometer or thermocouple in the center of the oven cavity.

Set the thermostat to 350°F degrees, the upper element 3-Heat switch to "Low", and the lower element 3-Heat switch to "High".

Allow the oven to heat for at least one hour before attempting any calibration check.

Watch the red indicator lamp below the thermostat dial. When the lamp comes on the oven elements are "cycling on", when the indicator lamp goes out the elements are "cycling off".

After the oven has heated of an hour record the temperature of the oven when the indicator lamp "cycles on".

Allow the oven to continue heating and record the temperature when the indicator lamp "cycles off".

Continue taking the "cycle on" and "cycle off" readings three times.

After 3 complete "cycles" average the six temperature readings (add them up and divide by 6). The average temperature should be within 25 degrees, plus or minus, of 350°F degrees.

CALIBRATION ADJUSTMENT

A 1/16 inch flat blade screwdriver with a 2 inch shaft is required to adjust the thermostat.

Maintain the oven temperature at 350°F degrees.

Without turning the thermostat dial, pull it off the shaft of the thermostat.

Locate the screw at the base of the thermostat shaft; this is the thermostat calibration screw.

Insert a small flat blade screwdriver down the thermostat shaft until it contacts the screw.

Grasp the thermostat shaft so it does not move while turning the calibration screw.

Use caution when making adjustments to the thermostat, a 1/8 turn of the calibration screw will adjust the oven temperature about 5 to 7 degrees.

To raise the oven temperature, turn the calibration screw Counter-Clock-Wise.

To lower the oven temperature, turn the calibration screw Clock-Wise.

Reinstall the oven knob and recheck the oven temperature

.

INSTALLATION TROUBLE SHOOTING GUIDE

SYMPTOM	PROBLEM	CAUSE
Not Heating	Breakers off	Reset Breakers
	Not Connected to Power	Connect to Power
	Improper Phasing at Terminal Block	Correct Phasing
	Defective Thermostat	Replace Thermostat
One Deck Works Others Do Not	Internal Circuit Breakers off	Reset Breakers
	Ovens Not Interconnected	
	Improper Phasing at Terminal Block	Connect all Decks to Lower Terminal Block Correct Phasing
Circuit Breakers Trip	Supply and Oven Voltage Do Not Match	Correct Voltage Mismatch
	Thermostat Capillary Tube Shorted to Element	Replace Thermostat to Clear Short
Too Long To Preheat	Supply and Oven Voltage Do Not Match	Correct Voltage Mismatch
	"3-Heat" Switches Set on Low	Set Switches to High

REVISION BLOCK		DESCRIPTION		DR.		MFG		ENG		DATE	
REV	ECNNO			DR		MFG		ENG		DATE	

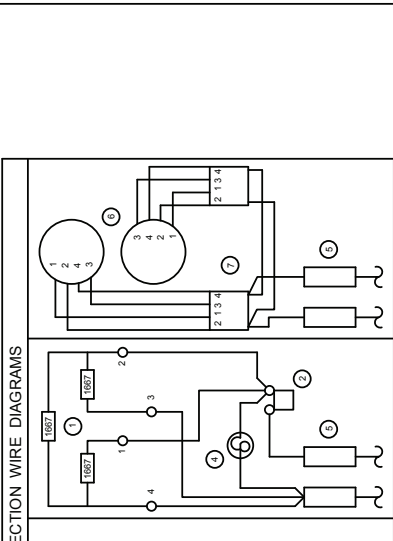

STAR	MODEL DESIGNATION	TOP ARRANGEMENT			LEGEND
		SEC-1	SEC-2	SEC-3	
RT36A	36S-0	A	A	C	1 HEAT ELEMENT 2 THERMOSTAT 3 HEAT SWITCH 4 PILOT LAMP 5 CIRCUIT BREAKER 6 SPEED UNIT 7 HEAT SWITCH
RT36B	36S-2	B	B	B	
RT36C	36S-3A	B	B	C	
RT36D	36S-10	A	A	A	
RT36E	36S-20	C	C	C	
RT36F	N/A	B	C	C	

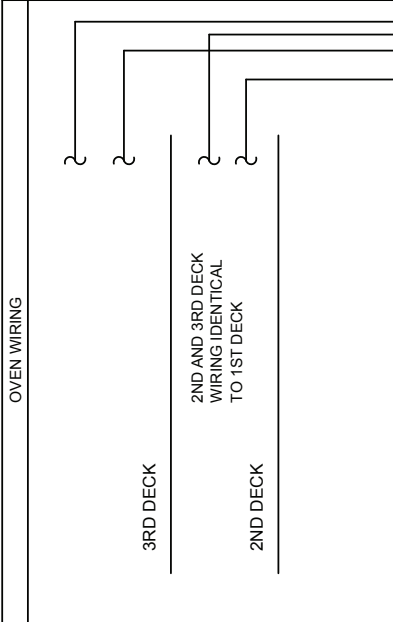

RANGE	ELECTRICAL CONNECTIONS		
	1st DECK	2nd DECK	3rd DECK
POWER SUPPLY	1-3-5	1	1
SINGLE PHASE	2-4-6	2	2
THREE PHASE	L1 3	1	1
	L2 1-5	2	1
	L3 2-4-6	-	2

STAR MODEL NUMBER	MODEL NUMBER	QTY	LOADING			KW TOTAL
			L1 L2	L2 L3	L3 L1	
RT36 + DO36	36S RANGE	-	6.0	10.0	5.0	21.0
DO36 OVEN	LA-136S OVEN	1	6.0	0.0	0.0	6.0
DO36 OVEN	LA-236S "	2	6.0	0.0	6.0	12.0
DO36 OVEN	LA-336S "	3	6.0	6.0	6.0	18.0

STAR MODEL NUMBER	MODEL NUMBER	QTY	LOADING			KW TOTAL
			L1 L2	L2 L3	L3 L1	
RT36 + DO36	36S RANGE	-	6.0	10.0	5.0	21.0
DO36 OVEN	LA-136S OVEN	1	6.0	0.0	0.0	6.0
DO36 OVEN	LA-236S "	2	6.0	0.0	6.0	12.0
DO36 OVEN	LA-336S "	3	6.0	6.0	6.0	18.0

STAR MODEL NUMBER	MODEL NUMBER	QTY	LOADING			KW TOTAL
			L1 L2	L2 L3	L3 L1	
RT36 + DO36	36S RANGE	-	6.0	10.0	5.0	21.0
DO36 OVEN	LA-136S OVEN	1	6.0	0.0	0.0	6.0
DO36 OVEN	LA-236S "	2	6.0	0.0	6.0	12.0
DO36 OVEN	LA-336S "	3	6.0	6.0	6.0	18.0

STAR MODEL NUMBER	MODEL NUMBER	QTY	LOADING			KW TOTAL
			L1 L2	L2 L3	L3 L1	
RT36 + DO36	36S RANGE	-	6.0	10.0	5.0	21.0
DO36 OVEN	LA-136S OVEN	1	6.0	0.0	0.0	6.0
DO36 OVEN	LA-236S "	2	6.0	0.0	6.0	12.0
DO36 OVEN	LA-336S "	3	6.0	6.0	6.0	18.0

STAR MODEL NUMBER	MODEL NUMBER	QTY	LOADING			KW TOTAL
			L1 L2	L2 L3	L3 L1	
RT36 + DO36	36S RANGE	-	6.0	10.0	5.0	21.0
DO36 OVEN	LA-136S OVEN	1	6.0	0.0	0.0	6.0
DO36 OVEN	LA-236S "	2	6.0	0.0	6.0	12.0
DO36 OVEN	LA-336S "	3	6.0	6.0	6.0	18.0

STAR MODEL NUMBER	MODEL NUMBER	QTY	LOADING			KW TOTAL
			L1 L2	L2 L3	L3 L1	
RT36 + DO36	36S RANGE	-	6.0	10.0	5.0	21.0
DO36 OVEN	LA-136S OVEN	1	6.0	0.0	0.0	6.0
DO36 OVEN	LA-236S "	2	6.0	0.0	6.0	12.0
DO36 OVEN	LA-336S "	3	6.0	6.0	6.0	18.0

STAR MODEL NUMBER	MODEL NUMBER	QTY	LOADING			KW TOTAL
			L1 L2	L2 L3	L3 L1	
RT36 + DO36	36S RANGE	-	6.0	10.0	5.0	21.0
DO36 OVEN	LA-136S OVEN	1	6.0	0.0	0.0	6.0
DO36 OVEN	LA-236S "	2	6.0	0.0	6.0	12.0
DO36 OVEN	LA-336S "	3	6.0	6.0	6.0	18.0

STAR MODEL NUMBER	MODEL NUMBER	QTY	LOADING			KW TOTAL
			L1 L2	L2 L3	L3 L1	
RT36 + DO36	36S RANGE	-	6.0	10.0	5.0	21.0
DO36 OVEN	LA-136S OVEN	1	6.0	0.0	0.0	6.0
DO36 OVEN	LA-236S "	2	6.0	0.0	6.0	12.0
DO36 OVEN	LA-336S "	3	6.0	6.0	6.0	18.0

USE ON ALL E SERIAL NUMBERS

QTY	ITEM#	PART NUMBER	DESCRIPTION	MATERIAL
LANG MANUFACTURING				
DR	DATE	2-1-94	TITLE	LA36 OVEN / 36S RANGE
OK	DATE			
UNITS: FRACTIONS DECIMALS 1/16 1/8 3/16 1/4 5/16 3/8 7/16 1/2 5/8 3/4 7/8 1 DIMENSIONS ARE IN INCHES				
NEXT HIGH PRIORITY:				SHEET
SCALE:				DRAWING NUMBER
TO FIT				1 OF 1
				2M-61106-01
				REV
				E

REVISION BLOCK			
REV	ECN NO.	DESCRIPTION	DATE

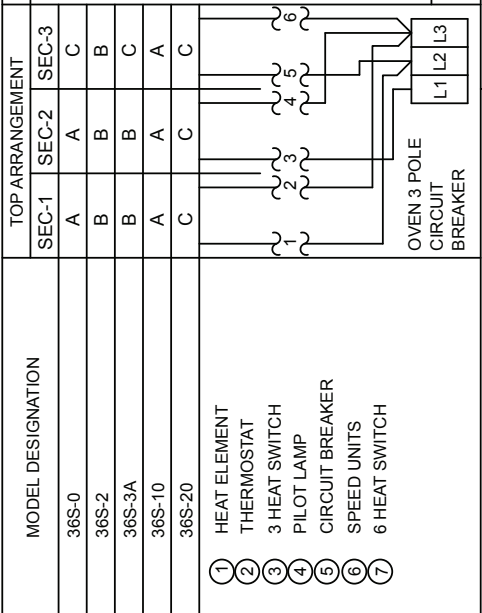
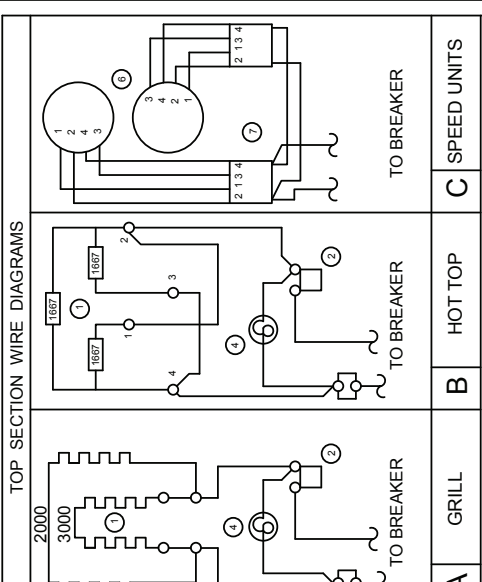

MODEL DESIGNATION	TOP ARRANGEMENT		
	SEC-1	SEC-2	SEC-3
36S-0	A	A	C
36S-2	B	B	B
36S-3A	B	B	C
36S-10	A	A	A
36S-20	C	C	C

OVEN 3 POLE CIRCUIT BREAKER

HEAT ELEMENT
THERMOSTAT
3 HEAT SWITCH
PILOT LAMP
CIRCUIT BREAKER
SPEED UNITS
6 HEAT SWITCH

ELECTRICAL CONNECTIONS

RANGE TOP CONNECT TO OVEN CIRCUIT BREAKER	UPPER OVENS CONNECT TO BOTTOM DECK TERMINAL BLOCK		
	1st DECK	2nd DECK	3rd DECK
THREE PHASE	L1	3	1
	L2	1-5	2
	L3	2-4-6	-

ELECTRICAL DATA

CONNECT WIRES FROM RANGE TOP TO OVEN CIRCUIT BREAKER. CONNECT WIRES FROM ADDITIONAL DECKS TO LOWER OVEN TERMINAL BLOCK

MODEL NUMBER	LOADING			KW	AMPS
	L1 L2	L2 L3	L3 L1		
36S RANGE	6.0	10.0	5.0	21.0	480 VOLT
LA-136 OVEN	6.0	0.0	0.0	6.0	
LA-236S "	6.0	0.0	6.0	12.0	
LA-336S "	6.0	6.0	6.0	18.0	

USE ON ALL E SERIAL NUMBERS

LANG MANUFACTURING

DATE: 2-1-94

TITLE: LA36 OVEN / 36S RANGE

480 VAC

SCALE: NONE

DRAWING NUMBER: 2M-61106-10

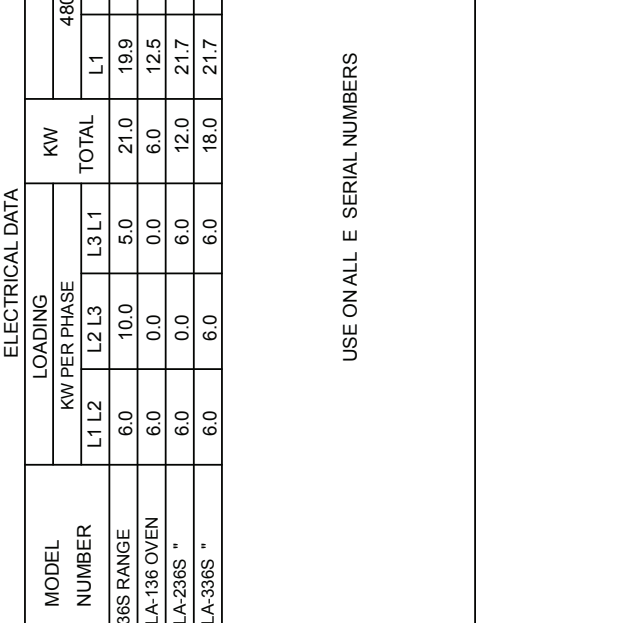
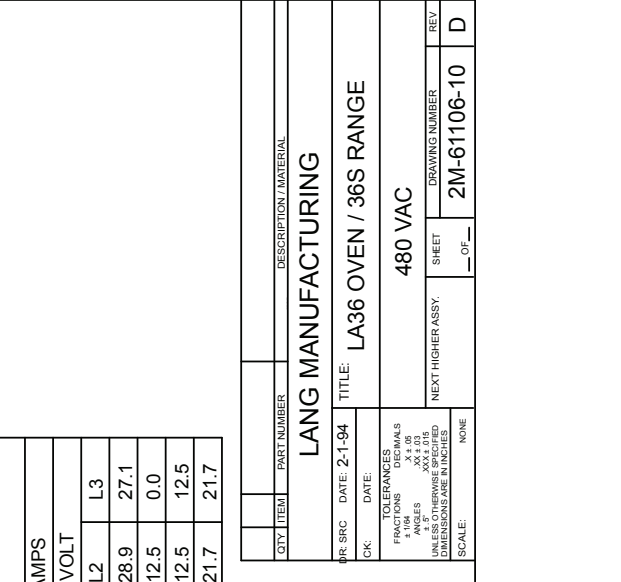

MODEL DESIGNATION	TOP ARRANGEMENT		
	SEC-1	SEC-2	SEC-3
36S-0	A	A	C
36S-2	B	B	B
36S-3A	B	B	C
36S-10	A	A	A
36S-20	C	C	C

OVEN 3 POLE CIRCUIT BREAKER

HEAT ELEMENT
THERMOSTAT
3 HEAT SWITCH
PILOT LAMP
CIRCUIT BREAKER
SPEED UNITS
6 HEAT SWITCH

ELECTRICAL CONNECTIONS

RANGE TOP CONNECT TO OVEN CIRCUIT BREAKER	UPPER OVENS CONNECT TO BOTTOM DECK TERMINAL BLOCK		
	1st DECK	2nd DECK	3rd DECK
THREE PHASE	L1	3	1
	L2	1-5	2
	L3	2-4-6	-

ELECTRICAL DATA

CONNECT WIRES FROM RANGE TOP TO OVEN CIRCUIT BREAKER. CONNECT WIRES FROM ADDITIONAL DECKS TO LOWER OVEN TERMINAL BLOCK

MODEL NUMBER	LOADING			KW	AMPS
	L1 L2	L2 L3	L3 L1		
36S RANGE	6.0	10.0	5.0	21.0	480 VOLT
LA-136 OVEN	6.0	0.0	0.0	6.0	
LA-236S "	6.0	0.0	6.0	12.0	
LA-336S "	6.0	6.0	6.0	18.0	

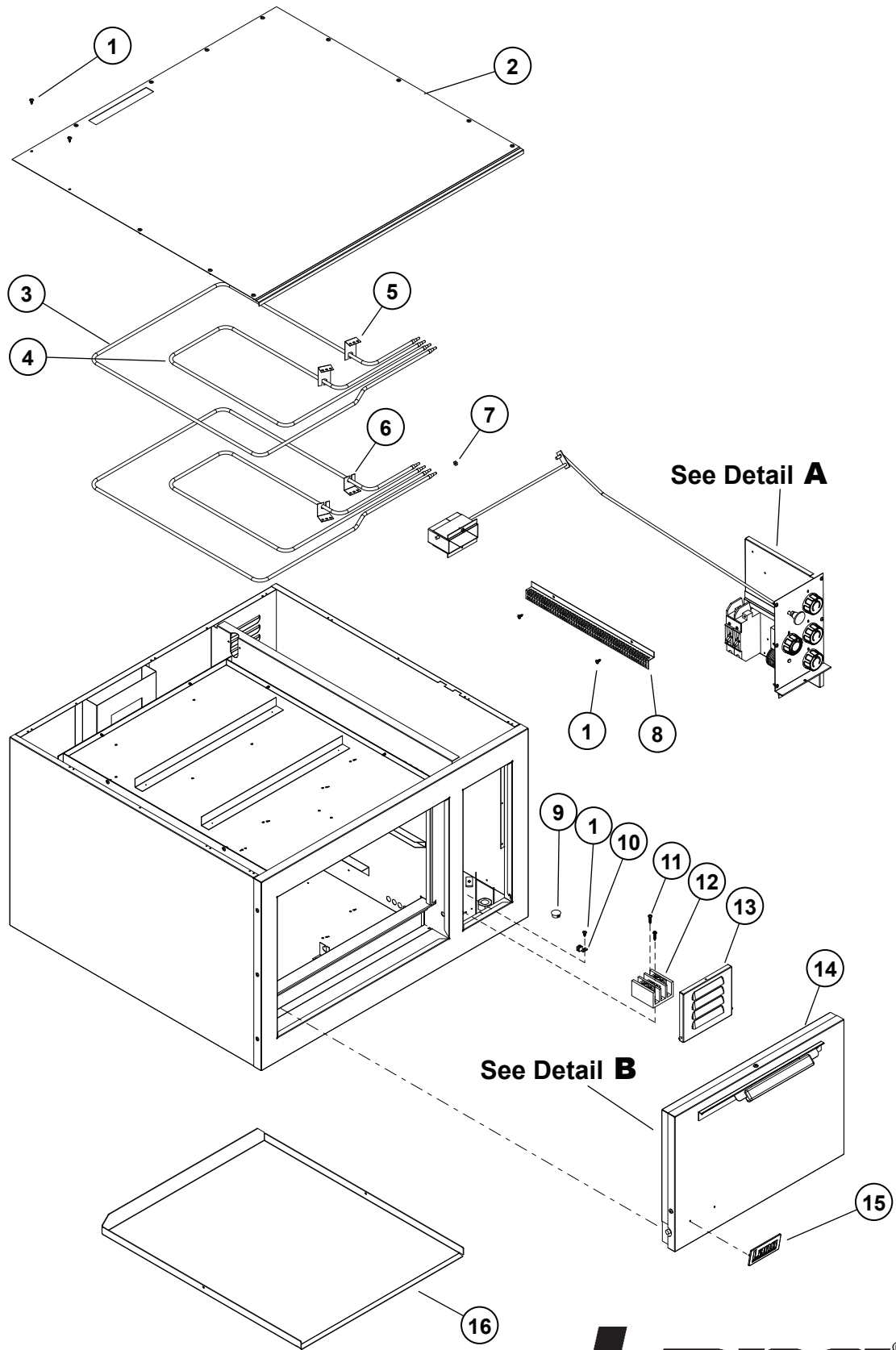

Model:
 DO36 Deck Oven
 LA36 Deck Oven

Lang[®]

SK2423

Rev. - 6/08/09

PARTS LIST

October 4, 2012, Rev A

Model: DO36 BAKE DECK OVEN				
Fig No	Part No	Qty	Description	Application
1	2C-20103-02	37	SCRW SM PLT 10 X .5 PHLSL	
2	N9-LA36-159	1	TOP LA OVEN S/S	DO36L (LOWER STACKED UNITS)
	N9-LA36-159-1			DO36
3	2N-11050-25	2	ELE 36OVN 240V O/S 1.8KW	DO36-240VM
	2N-11050-29		ELMNT 36" OVEN 480V O/S	DO36-440VM, DO36-480V, CLDO36L-440V
	2N-11050-31		ELE 36"OVN 208V O/S 1.8KW	DO36-208VM
	2N-11050-33		ELMNT 36" OVEN 380V O/S 1.8KW	DO36-380VM
4	2N-11050-26	2	ELE 36OVN 240V I/S 1.2KW	DO36-240VM
	2N-11050-30		ELMNT 36" OVEN 480V I/S	DO36-440VM, DO36-480V, CLDO36L-440V
	2N-11050-32		ELE 36"OVN 208V I/S 1.2KW	DO36-208VM
	2N-11050-34		ELMNT 36" OVEN I/S 1.2KW	DO36-380VM
5	P9-50301-09	12	LONG ELEMENT CLIP S/S	
6	P9-50301-10	12	SHORT ELEMENT CLIP	
7	2C-20301-15	8	NUT HEX 10-32 PLTD	
8	N9-LA36-109-1	1	CAPILLARY SHIELD	
9	2P-70901-05	1	PLGBTNBLKPLSTC 3/4DP-750	
10	2E-31200-02	1	LUG GROUNDING UL APPROVED	
11	2C-20103-01	2	SCRW SM PLT 10X7/8 PHIL	
12	2E-30500-07	1	TRM BLOCK 3PLELRGE 125AMP	
13	N9-LA36-128	1	SWITCH DOOR ASSY	
14	N9-LA36-193	1	DOOR ASSY A/L	
15	2M-60301-43	1	DIE CAST PLT LANG SATIN	
16	N9-LA36-184	1	DECK CHANNEL ASSY A/L	
NI	2A-72500-06	4	LEG 5 1/2 W/BOLT DOWN ADJ	CLDO36L-440V
NI	2B-50200-09	1	RACK 36 OVEN	
NI	2B-50200-52	1	RACK 36 OVEN CRUISE LINE	CLDO36L-440V

**IMPORTANT: WHEN ORDERING, SPECIFY VOLTAGE OR TYPE GAS DESIRED
INCLUDE MODEL AND SERIAL NUMBER**

PAGE 1
OF 1

Some items are included for illustrative purposes only and in certain instances may not be available.



Lang[®]

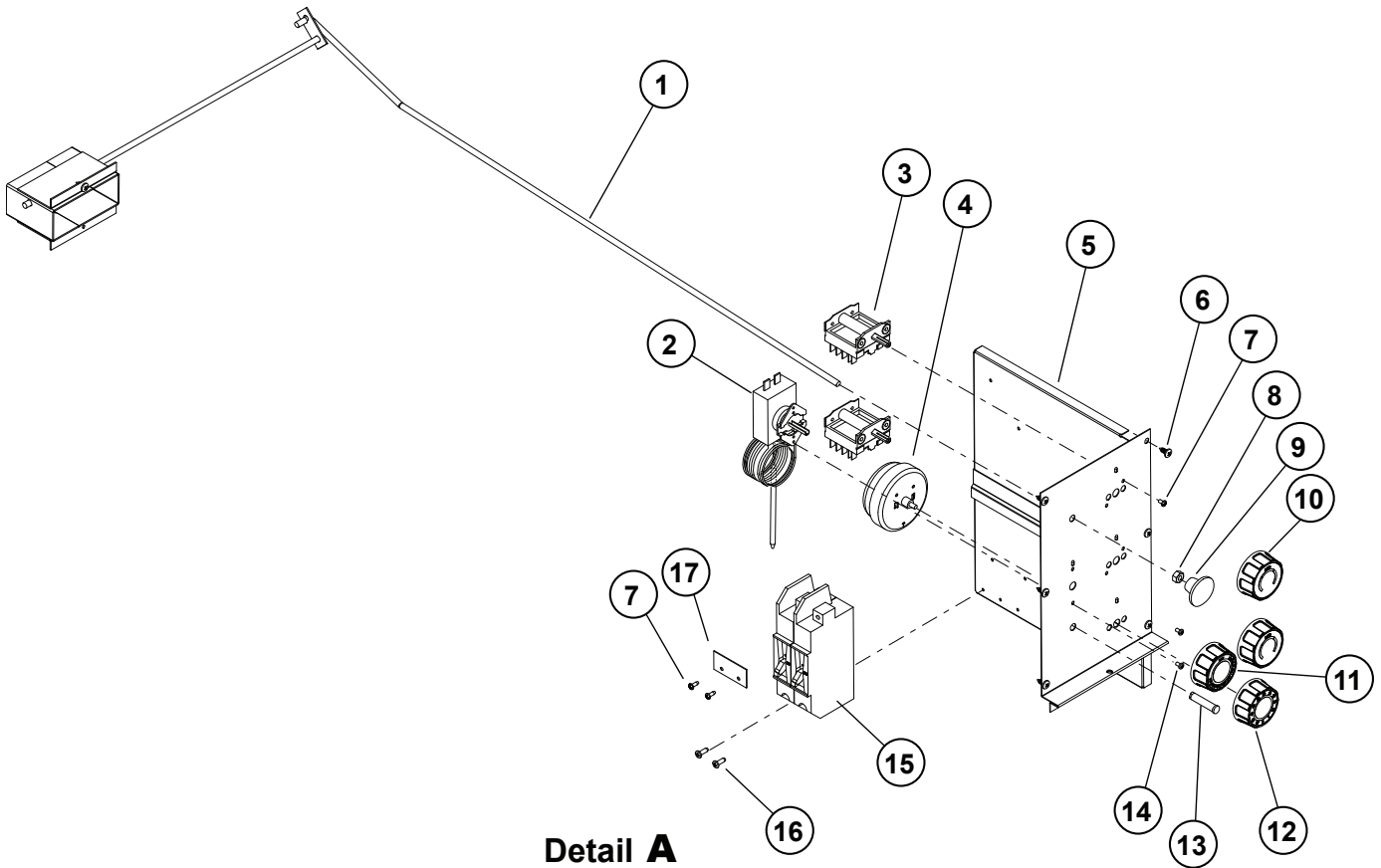

Detail A

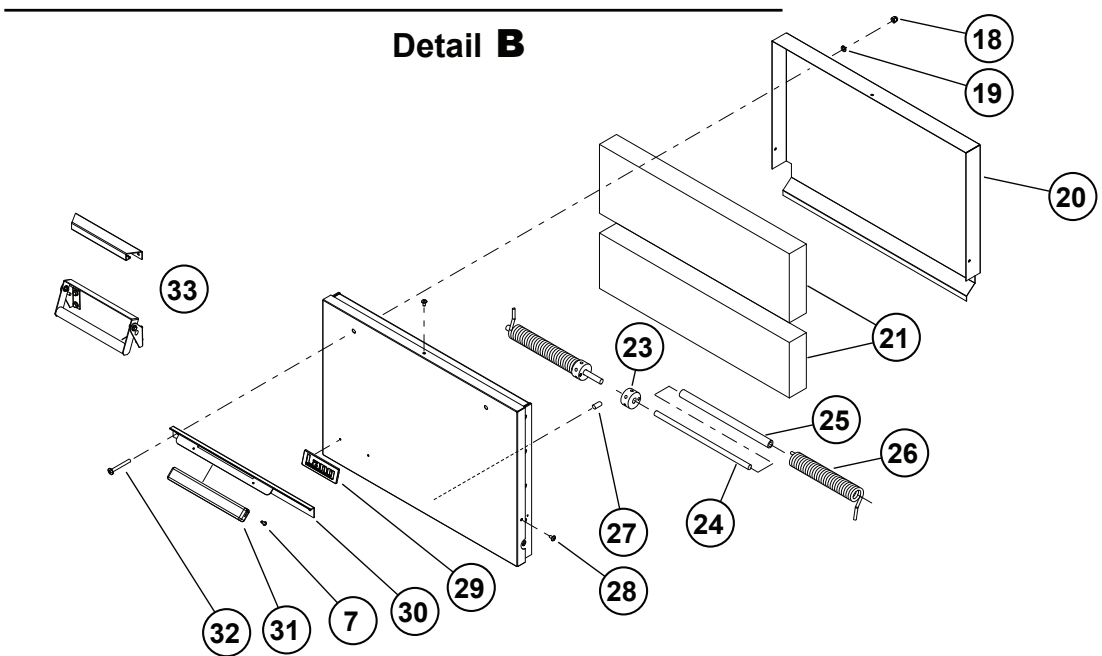

Detail B

Model:
 DO36 Deck Oven, Details A & B
 LA36 Deck Oven, Details A & B

Lang[®]

SK2424 Rev. B 2/27/2013

PARTS LIST

February 27, 2013, Rev A

DO36 36" BAKE DECK OVEN Details A & B				
Fig No	Part Number	Qty	Descr	Application
1	N9-LA36-116	1	VENT PIPE ASSY	
2	2T-30402-07	1	STAT ADJ 550o 48 C/T	
3	PS-60101-W3	2	KIT - 3 POS SWITCH REPL	
4	2J-30801-01	1	TIMER MECHANICAL LONG	
5	N9-LA36-130	1	CONTROL SLIDE ASSY	
6	2C-20103-02	37	SCRW SM PLT 10 X .5 PHLSL	
7	2C-20102-06	4	SCRW PHD ST 6-32X3/8	
8	2C-20303-01	1	NUT HX SS 1/4-20	
9	2R-70701-25	1	KNOB DAMPER BLACK PLAIN	
10	Y9-70701-10	2	KNOB 3-HEAT 208-240V, BLACK	
	Y9-70701-10-2		KNOB 3-HEAT 208-240V, RED	
11	Y9-70701-12	1	KNOB ASSYEMBLY 550°F, BLACK	
	Y9-70701-12-2		KNOB ASSYEMBLY 550°F, RED	
12	Q9-70701-09	1	KNOB ASSY MANUAL TIMER	
13	2J-31601-01	1	PILOT LT 250V 6LEAD BLK	DO36-208VM
	2J-31601-02		PILOT LT 480V 6LEAD BLK	DO36-480V, DO36-480VM
14	2C-20101-77	2	SCRW MS PLT 6-32 X .25	
15	2E-31800-01	2	CB 250V50A 1 POLE CRLNGSW	DO36-208VM
	2E-31800-04	1	CB 480V 50A 3-POLE	DO36-480V, DO36-480VM, CLDO36L-440V
16	2C-20102-04	4	SCRW PHD ST 8-32X.5 PLTD	
17	Q9-50312-81	1	BREAKER HOLDER	
18	2C-20301-29	2	NUT HEX ACORN 1/4-20 S/S	
19	2C-20204-02	2	WASHER SS 1/4 SPLIT LOCK	
20	N9-LA36-142	1	DOOR INSIDE PANEL	
21	2H-60106-31	1	INSULATION KIT DOOR	
23	2A-50800-07	2	TENSION DISC STD OVEN	
24	2A-LA36-145	2	DOOR RODS LA36	
25	2A-LA36-146	2	DOOR PIPE LA36	
26	2P-51001-01	1	SPRING OVN LH DOOR	
	2P-51001-02		SPRING OVN RH DOOR	
27	2C-20105-04	2	SCREW SET 1/4-20X1/2	
28	2C-20101-24	3	SCRW MS PLT 10-32 X .375	
29	K9-60301-43-1	1	DIE CAST LOG + TINNERMAN	
30	P9-50312-79	1	RANGE HANDLE	
31	2R-50800-91	1	DOOR HANDLE	
32	2C-20101-10	2	SCRW THD MS 1/4-20X2 1/4	
33	Y9-50300-38	1	HANDLE MARINE	MARINE APPLICATIONS

**IMPORTANT: WHEN ORDERING, SPECIFY VOLTAGE OR TYPE GAS DESIRED
INCLUDE MODEL AND SERIAL NUMBER**

PAGE 1
OF 1

Some items are included for illustrative purposes only and in certain instances may not be available.



STAR INTERNATIONAL HOLDINGS INC. COMPANY
Star - Holman - Lang - Wells - Bloomfield - Toastmaster
10 Sunnen Drive, St. Louis, MO 63143 U.S.A.
(314) 678-6303
www.star-mfg.com