



**HV-100G and DFG-100**  
Hydrovection Stacked on a Full-Size Gas Convection Oven



Project \_\_\_\_\_

Item No. \_\_\_\_\_

Quantity \_\_\_\_\_

Requires Blodgett stacking kit #52874.

This model consists of a standard HV-100G stacked on a standard DFG-100. For more information on each oven refer to the the HV-100G and DFG-100 specifications sheets.

**SHORT FORM SPECIFICATIONS** Provide Blodgett model HV-100G Hydrovection stacked on a model DFG-100 full-size gas convection oven.

**HV-100G Hydrovection** - Shall have fully welded 316 stainless steel liner. Liner to be covered top and bottom. Unit shall accept five 18" x 26" standard full-size bake pans. Doors shall be triple mounted, black glass with dual pane thermal glass windows, curved handle and simultaneous operation. Unit shall be heated by 70,000 BTU gas burner. Air in baking chamber distributed by single inlet blower wheel powered by a four speed, auto-reversing, 3/4 HP motor with thermal overload protection. Each chamber shall be fitted with bright halogen lamps, and five standard stainless steel removable racks. Unit shall have programmable manual control capable of storing 100 recipes. Control shall feature incremental moisture control, hot air, cool down modes, core probe cook & hold and USB connection. Breaker shut off switch on front panel for easy service. 1 year parts and 1 year labor warranty.

**DFG-100** - Shall have (porcelainized/stainless) steel liner and shall accept five 18" x 26" standard full-size bake pans. Stainless steel front, top and sides. Doors shall be (solid stainless steel/ have dual pane thermal glass windows) with single porcelain handle and simultaneous operation. Unit shall be gas heated with electronic spark ignition and shall cook by means of a dual-flow system combining direct and indirect heat with a gas shutoff switch on the front of the control panel. Air in baking chamber distributed by dual inlet blower wheel powered by a two-speed, 1/3 HP motor with thermal overload protection. Each chamber shall be fitted with two commercial lamps and five chrome-plated removable racks. Control panel shall be recessed with Cook/Cool Down mode selector, solid state (manual/digital) infinite thermostat (200-500°F), and 60-minute timer. 1 year parts and 1 year labor, three year limited door warranty.

**SHIPPING INFORMATION:**

**Approximate Weight:**

HV-100G 520 lbs. (236 kg)

DFG-100 617 lbs. (280 kg)

**Crate size:**

Each section 37-1/2" (952mm) x 43-1/2" (1105mm) x 52" (1321mm)

**HV-100G STACKED ON A DFG-100**

**BLODGETT OVEN COMPANY**

www.blodgett.com

44 Lakeside Avenue, Burlington, VT 05401 • Phone: (802) 658-6600 • Fax: (802) 864-0183



# HV-100G STACKED ON A DFG-100

DIMENSIONS ARE IN INCHES (MM)

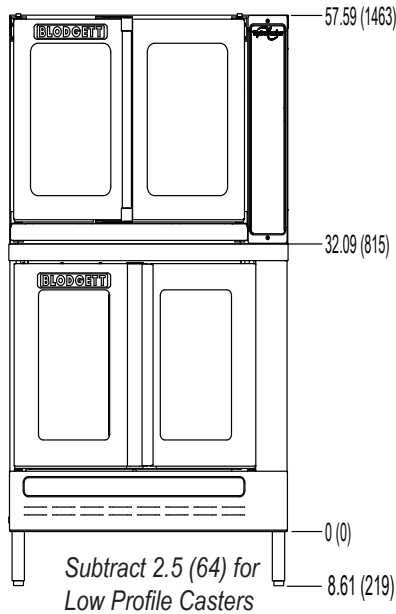

FRONT VIEW

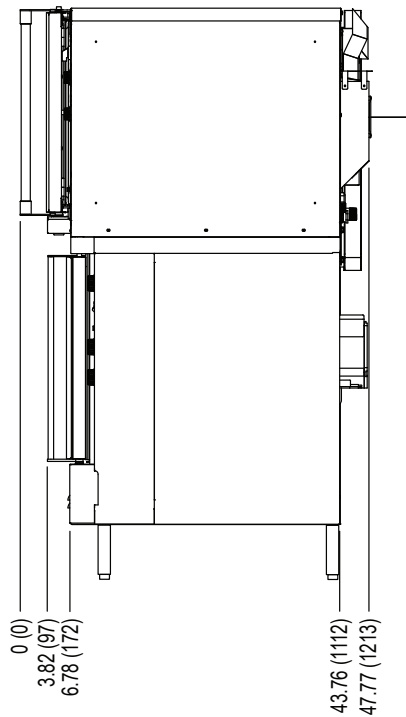

SIDE VIEW

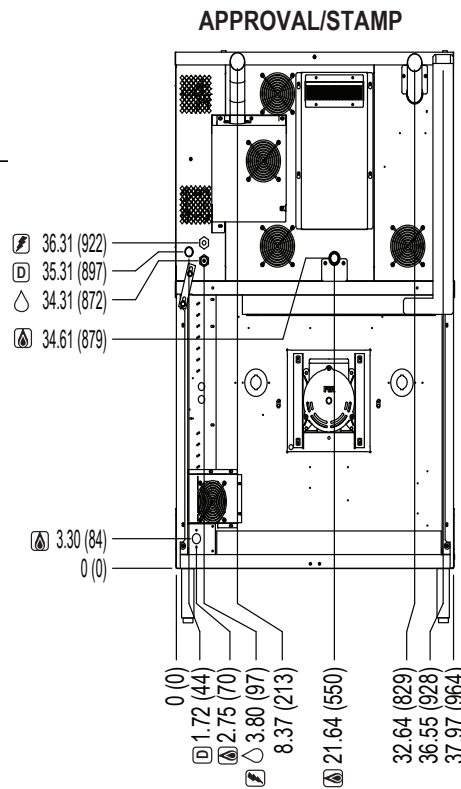

BACK VIEW

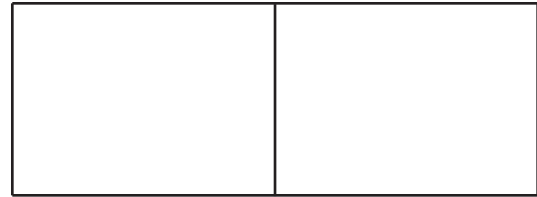

APPROVAL/STAMP

## PRODUCT CLEARANCE:

6" (152mm) from combustible and non-combustible construction

## MAXIMUM INPUT:

HV-100G 60,000 BTU/hr  
DFG-100 55,000 BTU/hr

## GAS SUPPLY:

### HV-100G

3/4" NPT

Inlet Pressure:

Natural 7.0" W.C. static to unit

Propane 14.0" W.C. static to unit

### DFG-100

3/4" NPT

Manifold Pressure:

• Natural – 3.5" W.C. • Propane – 10" W.C.

Inlet Pressure:

• Natural – 7.0" W.C. min. – 10.5" W.C. max.

• Propane – 11" W.C. min. – 13.0" W.C. max.

## POWER SUPPLY - DFG-100

115 VAC, 1 phase, 6 Amp, 60 Hz., 2-wire with ground,  
1/3 H.P., 2 speed motor, 1140 and 1725 RPM  
6' (1.8m) electric cord set furnished on 115 VAC ovens only.

Blodgett recommends a Pass & Seymour, model 2097, GFCI due to the use of a variable frequency drive. Must be hard wired in some cases.

## POWER SUPPLY - HV-100G

### HV-100G

Standard 115VAC, 10 amp, Nema 5-20R dedicated receptacle

Option 208/240VAC, 5 amp, Nema 6-15 dedicated receptacle

Export Export voltages available on request

## WATER & DRAIN CONNECTION - HV-100G

**Drain** 1" NPT drain connection Maximum drain temperature 140°F (60°C)

**Water** 3/4" NPT garden hose - cold water only

The drain piping must consist of temperature resistant material, greater than 160°F, and be of adequate diameter not to cause flow restriction. Improper materials may deform and cause restrictions, thus affecting performance.

Appliance is to be installed with backflow protection in accordance with Federal, State or Local codes.

## WATER SUPPLY - HV-100G

Good quality water feed is the responsibility of the owner. Water quality must be within the following general guidelines.

TDS: 40-125 ppm Hardness: 35-100 ppm pH: 7.0 - 8.5  
Silica: <13 ppm Chlorides: <25 ppm Chlorine: <0.2 ppm  
Chloramine: <0.2 ppm

The best defense against poor water quality is a water treatment system designed to meet your water quality conditions. Blodgett offers optional systems from Optipure.

**Water Pressure** 30(min)-50(max) PSI  
**Water Consumption** 2.5 - 4.0 GPH based on cooking mode

**NOTE:** The company reserves the right to make substitutions of components without prior notice