



IMPORTANT FOR FUTURE REFERENCE
Please complete this information and retain this manual for the life of the equipment:

Model #: _____
Serial #: _____
Date Purchased: _____

INSTALLATION & OPERATION MANUAL

Gas Cabinet Base Convection Steamer GCX-0% GCX-24

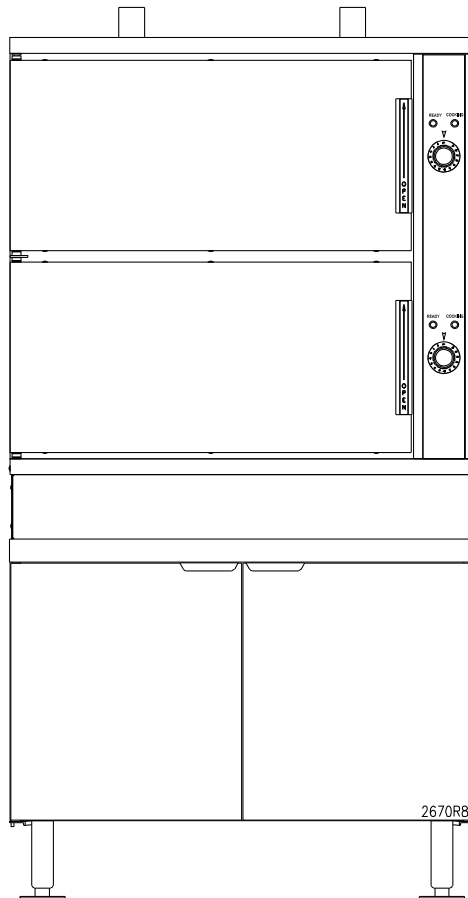

WARNING

Improper installation, adjustment, alteration, service or maintenance can cause property damage, injury or death. Read the installation, operating and maintenance instructions thoroughly before installing or servicing this equipment.

CROWN FOOD SERVICE EQUIPMENT

 A Middleby Company

70 Oakdale Road, Downsview (Toronto) Ontario, Canada, M3N 1V9
Telephone: 919-762-1000 www.crownsteamgroup.com

Printed in Canada



INSTALLATION AND OPERATION MANUAL,
GAS CABINET BASE CONVECTION STEAMER, GCX-16, GCX-24

IMPORTANT NOTES FOR INSTALLATION AND OPERATION



This is the safety alert symbol. It is used to alert you to potential personal injury hazards. Obey all safety messages that follow this symbol to avoid possible injury or death.



WARNING: Improper installation, operation, adjustment, alteration, service or maintenance can cause property damage, injury or death. Read the installation, operating and maintenance instructions thoroughly before installing, operating or servicing this equipment.

This manual should be retained for future reference.



FOR YOUR SAFETY: Do not store or use gasoline or other flammable vapors or liquids in the vicinity of this or any other appliance.

Intended for commercial use only. Not for household use.

PURCHASER: Instructions to be followed in the event that the operator of this appliance smells gas must be posted in a prominent location. This information shall be obtained by consulting the local gas supplier.

Keep the appliance area free and clear from combustibles.

Do not obstruct the flow of combustion and ventilation air.

Adequate clearances must be maintained for servicing and proper operation.

Do not attempt to operate this unit in the event of a power failure.

INSTALLATION AND OPERATION MANUAL,
GAS CABINET BASE CONVECTION STEAMER, GCX-16, GCX-24

TABLE OF CONTENTS

DESCRIPTION	PAGE
Important Notes for Installation and Operation	2
1.0 Service Connections	4
2.0 Introduction	4
3.0 Installation Instructions	7
4.0 Operation Instructions	12
5.0 Operation Instructions for Boilers with CSD-1 Controls	14
6.0 Operation Instructions, Cooker Section	18
7.0 Periodic Maintenance	20
8.0 Cleaning Instructions	23
9.0 Adjustments	24
10.0 Troubleshooting	26

INSTALLATION AND OPERATION MANUAL, GAS CABINET BASE CONVECTION STEAMER, GCX-16, GCX-24

1.0 SERVICE CONNECTIONS

SERVICE CONNECTIONS

- ⚡ - ELECTRICAL CONNECTION: 1/2" conduit connection to controls. 120VAC-60Hz-1PH
2 AMPS per compartment or to be specified on data plate.
- 💧 - BOILER FEED WATER: 1/2" NPT, 25-50 PSI(170-345 kPa)
- 💧 - CONDENSATE COLD WATER: 1/2" NPT, 25-50 PSI(170-345 kPa)
- 💧 - DRAIN: 2"IPS piped to open floor drain. No Solid Connection.
- 💧 - GAS CONNECTION: 3/4"IPS supply line required.
- 🔌 - STEAM TAKE-OFF CONNECTION: 3/4"IPS optional to operate adjacent equipment.

WATER QUALITY STATEMENT

Water is the essential ingredient in steam equipment, water quality is the major factor affecting the performance of your appliance. Crown Steam Group offers a Comprehensive Water Treatment System which exceeds our minimum water requirements. Proof of installation and proper cartridges replacement is required for warranty coverage. Water supply to Crown Steam Group steamers must be within these guidelines:

Total dissolved solids	Less than 60 PPM
Total alkalinity	Less than 20 PPM
Silica	Less than 13 PPM
Chlorine	Less than 1.5 PPM
pH Factor	6.8-7.3

Water which does not meet these standards should be treated with the installation of Crown Steam Group's Water Treatment System. Call 919-762-1000 if you have questions concerning your water meeting these parameters.

*Failure or malfunction of this appliance due to poor water quality is not covered under warranty.
Reference www.crownsteamgroup.com for complete warranty details and instructions.

MODEL	GAS SUPPLY			INSTALLATION CLEARANCE		
	BTU/HR.	kW/HR.	WATER COLUMN PRESSURES		SIDES	BACK
GCX-16	300,000	87.9	Natural Gas	Propane	3.00"	6.00"
			min. 4" (102mm)	min. 11" (279 mm)		

* Use on non-combustible floors only.

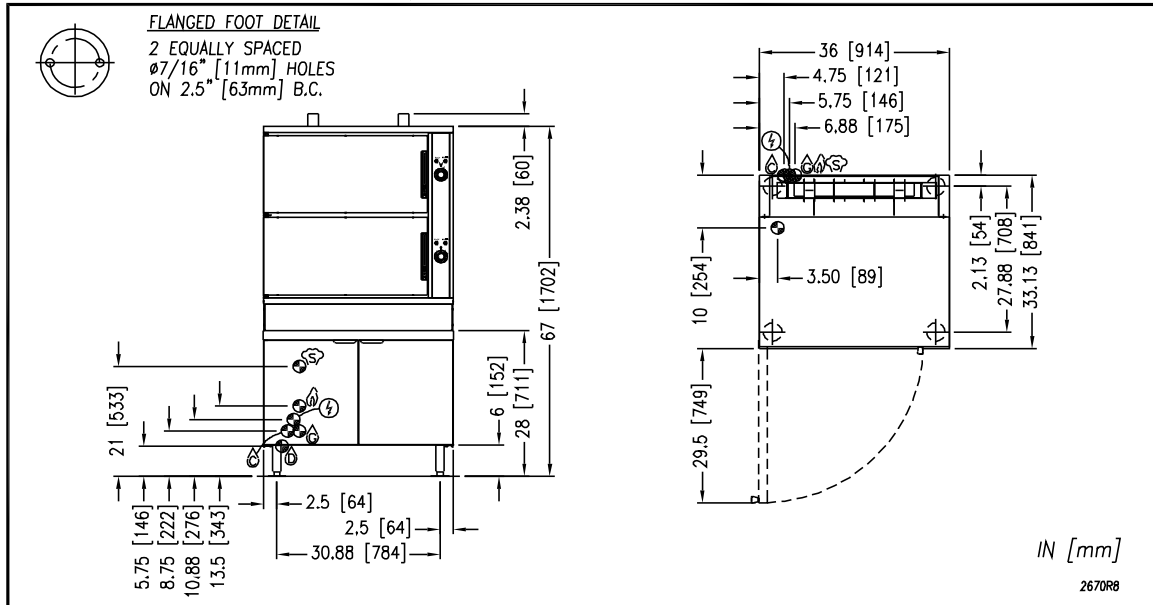

As continued product improvement is a policy of Crown, specifications are subject to change without notice.

INSTALLATION AND OPERATION MANUAL, GAS CABINET BASE CONVECTION STEAMER, GCX-16, GCX-24

1.0 SERVICE CONNECTIONS

SERVICE CONNECTIONS

- ⚡ - ELECTRICAL CONNECTION: 1/2" conduit connection to controls. 120VAC-60Hz-1PH
2 AMPS per compartment or to be specified on data plate.
- 💧 - BOILER FEED WATER: 1/2" NPT, 25-50 PSI(170-345 kPa)
- 💧 - CONDENSATE COLD WATER: 1/2" NPT, 25-50 PSI(170-345 kPa)
- 💧 - DRAIN: 2"IPS piped to open floor drain. No Solid Connection.
- 🔥 - GAS CONNECTION: 3/4"IPS supply line required.
- 🌀 - STEAM TAKE-OFF CONNECTION: 3/4"IPS optional to operate adjacent equipment.

WATER QUALITY STATEMENT

Water is the essential ingredient in steam equipment. Water quality is the major factor affecting the performance of your appliance. Crown Steam Group offers a Comprehensive Water Treatment System which exceeds our minimum water requirements. Proof of installation and proper cartridges replacement is required for warranty coverage. Water supply to Crown Steam Group steamers must be within these guidelines:

Total dissolved solids	Less than 60 PPM
Total alkalinity	Less than 20 PPM
Silica	Less than 13 PPM
Chlorine	Less than 1.5 PPM
pH Factor	6.8-7.3

Water which does not meet these standards should be treated with the installation of Crown Steam Group's Water Treatment System. Call 919-762-1000 if you have questions concerning your water meeting these parameters.

*Failure or malfunction of this appliance due to poor water quality is not covered under warranty.
Reference www.crownsteamgroup.com for complete warranty details and instructions.

MODEL	GAS SUPPLY		INSTALLATION CLEARANCE	
	BTU/HR.	kW/HR.	NATURAL GAS	PROPANE
GCX-24	300,000	87.9	Natural Gas	Propane
			min. 4" (102mm)	min. 11" (279 mm)
			SIDES	BACK
			3.00"	6.00"

* Use on non-combustible floors only.

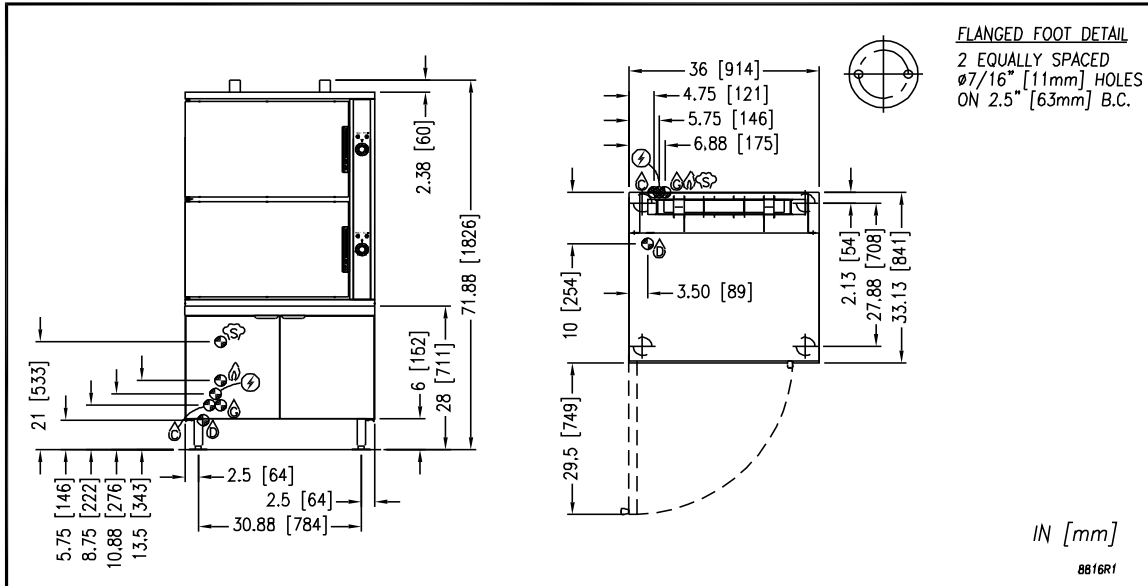

As continued product improvement is a policy of Crown, specifications are subject to change without notice.

INSTALLATION AND OPERATION MANUAL,
GAS CABINET BASE CONVECTION STEAMER, GCX-16, GCX-24

2.0 INTRODUCTION

DESCRIPTION

Models GCX-16 and GCX-24, convection steamers mounted on a 36" cabinet base and a gas fired boiler rated at 300,000 BTU. GCX-16 steamer has a pan capacity of 16 (2½") pans. GCX-24 steamer has a pan capacity of 24 (2½") pans.

BASIC FUNCTION:

Gas Fired Steamers

The sequence of operation is as follows:

1. Turn on main power switch. Pilot light will indicate main power is on and fill solenoid will open and water will begin to fill boiler. Allow 20 minutes to fill boiler. OFF shuts off the boiler controls and opens the automatic blowdown valve, if so equipped, emptying the boiler and releasing water and steam to the drain. Manual valve will have to be opened to drain boiler if not equipped with automatic blowdown valve.
2. Boiler pressure gauge should read 9 - 11 psi during operation, 0 psi during shutdown.
3. Burners will cycle on and off as required to maintain pressure.
4. Compartment cooker is ready for use when READY light is on. Place pans of food to be cooked into compartments and close doors(s).
5. Set timer to cooking time desired. Cooking will commence and cooking time may be interrupted at any time by opening door and resumed again by closing door.
6. Buzzer will sound indicating the end of the cooking cycle and that steam has stopped entering the compartment. The COOKING pilot will go off and the READY light will come on. Buzzer must be shut off by turning the timer to its off position.

INSTALLATION AND OPERATION MANUAL,
GAS CABINET BASE CONVECTION STEAMER, GCX-16, GCX-24

3.0 INSTALLATION INSTRUCTIONS

GENERAL

The gas boiler is designed to ASME Code and approved as a steam heating boiler restricted to operation at pressure not to exceed 15 psi. The gas boiler installed in a 36" cabinet base rated at 300,000 BTU, operational on Natural or Propane gas. Boilers may have optional electronic ignition and CSD-1 controls.

UNPACKING

Immediately after unpacking, check for possible shipping damage. If the appliance is found to be damaged, save the packaging material and contact the carrier within 15 days of delivery.

Before installing, verify that the gas (natural or propane), the elevation from sea level and the electrical supply agree with the specification on the data plate. NOTE: If this appliance is being installed above 2000 feet altitude, contact your authorized service office to assure that the proper orifice size for your elevation has been installed.

LOCATION

The installation location must be kept free and clear of combustibles. Do not obstruct the flow of combustion and ventilation air. Clearance from combustible construction must be a minimum of 3 inches from the sides and 6 inches from the back. The appliance should be installed on a noncombustible floor. Provide adequate clearances for cleaning, maintenance, service and proper operation.

Sufficient air should be allowed to enter the room to compensate for the amount of air removed by any ventilating system and for combustion for the gas burners. Do not obstruct the air flow into and around the appliance. Do not obstruct the flow of flue gases from the flue duct located at the rear and above the cabinet. Position the appliance in its final location. Check that there are sufficient clearances to service the controls, for door swings, etc., so there will be no problem in making the required supply and drain connections.

Allow enough space between any other piece of equipment or a wall for service access. Service on the cabinet base may require access to the left and/or right side panels.

INSTALLATION AND OPERATION MANUAL,
GAS CABINET BASE CONVECTION STEAMER, GCX-16, GCX-24

3.0 INSTALLATION INSTRUCTIONS (Continued)

INSTALLATION CODES AND STANDARDS

The appliance must be installed in accordance with:

Gas installation to conform to local codes, or in absence of local codes, with the National Fuel Gas Code - ANSI Z223.1/NFPA 54, or the Natural Gas and Propane Installation Code, CSA B149.1, as applicable, including:

1. The appliance and its individual shut off valve must be disconnected from the gas supply piping system during any pressure testing of that system at pressures in excess of ½ psig (3.5 kPa).
2. The appliance must be isolated from the gas supply piping system by closing its individual manual shut off valve during any pressure testing of the gas supply piping system at test pressures equal to or less than ½ psig (3.5 kPa).

Electrical grounding must be provided in accordance with local codes, or in the absence of local codes, with the National Electrical Code ANSI/NFPA 70. In Canada, installation must be in accordance with the Canadian Electrical Code CSA C22.2.

WIRING DIAGRAM FOR APPLIANCE IS LOCATED INSIDE CABINET DOOR.

LEVELLING AND ANCHORING THE APPLIANCE

1. Place appliance in the installation position.
2. Place a carpenter's level on top of the appliance and turn the adjustable feet to level side-to-side and front-to-back.
3. Mark hole locations on the floor through the anchoring holes provided in the rear flanged adjustable feet.
4. Remove appliance from installation position and drill holes in locations marked on the floor. Insert proper anchoring devices (not supplied).
5. Place appliance back in the installation position.
6. Place carpenter's level on top of appliance and re-level side-to-side and front-to-back.
7. Bolt and anchor appliance securely to the floor.
8. Seal bolts and flanged feet with Silastic or equivalent compound.

INSTALLATION AND OPERATION MANUAL,
GAS CABINET BASE CONVECTION STEAMER, GCX-16, GCX-24

3.0 INSTALLATION INSTRUCTIONS (Continued)

EXHAUST FANS AND CANOPIES:

Canopies are set over ranges, ovens, kettles, etc., for ventilation purposes. It is recommended that a canopy extend 6" past the appliance and be located 6 feet 6 inches from the floor. Filters should be installed at an angle of 45 degrees or more with the horizontal. This position prevents dripping of grease and facilitates collecting the run-off grease in a drip pan, usually installed with the filter. A strong exhaust fan tends to create a vacuum in the room and may interfere with burner performance or may extinguish pilot flames. Makeup air openings approximately equal to the fan area will relieve such vacuum. In case of unsatisfactory performance on any appliance, check with the exhaust fan in the "OFF" position.

PLUMBING CONNECTIONS



WARNING: Plumbing connections must comply with applicable sanitary, safety, and plumbing codes.

WATER SUPPLY CONNECTION

The incoming cold water supply connection, at the rear of the steamer cabinet, requires 3/8" tubing and water pressure of 25 - 50 psi. A manual shut-off valve must be provided convenient to the appliance; this valve should be open when the boiler is in operation.

IMPORTANT: If your equipment was supplied with split water lines and a water treatment system, connect the system to the connection marked "FILTERED WATER IN" only (use cold water). Make a second connection to the "CONDENSER WATER IN" from a cold and unfiltered water supply.

FAILURE OR MALFUNCTION OF THIS APPLIANCE DUE TO POOR WATER QUALITY IS NOT COVERED UNDER WARRANTY. SEE WATER QUALITY STATEMENT (PAGE 4).

INSTALLATION AND OPERATION MANUAL,
GAS CABINET BASE CONVECTION STEAMER, GCX-16, GCX-24

3.0 INSTALLATION INSTRUCTIONS (Continued)

DRAIN CONNECTION

The steamer drain (2" IPS) should be piped to a floor drain near the steamer (NOT directly under the steamer). There should be no solid drain connection; an "open gap" between the steamer and the floor drain is required.

GAS CONNECTION



NOTICE: If this equipment is being installed at over 2,000 feet altitude and was not so specified on order, contact service department. Failure to install with proper orifice sizing may void the warranty.

1. The data plate on the cabinet door of the boiler indicates the type of gas your unit is equipped to burn. DO NOT connect to any other gas type.

Keep the appliance area free and clear from combustible substances. Do not obstruct the flow of combustion and ventilation air.

2. A 3/4" NPT line is provided at the rear for the connection. Each boiler is equipped with an internal pressure regulator which is set at 3.5" W.C. manifold pressure for natural gas or 10.5" W.C. for LP gas. Use the 1/8" pipe tap on the burner manifold for checking pressure.

An adequate gas supply is necessary. Undersized or low pressure lines will restrict the volume of gas required for satisfactory performance. A steady supply pressure, between 7" W.C. and 14" W.C. for natural gas and 11" W.C. and 14" W.C. for propane gas is recommended. With all units operating simultaneously, the manifold pressure on all units should not show any appreciable drop. Fluctuations of more than 25% on natural gas, and 10% on propane gas, will create pilot problems and affect burner operating characteristics. Contact your gas company for correct supply line sizes.

Purge the supply line to clean out any dust, dirt, or foreign matter before connecting the line to the unit.



CAUTION: The pipe thread compound used when installing pipes must be a type that is resistant to the action of liquified petroleum or propane gases.

INSTALLATION AND OPERATION MANUAL,
GAS CABINET BASE CONVECTION STEAMER, GCX-16, GCX-24

3.0 INSTALLATION INSTRUCTIONS (Continued)

Codes require that a gas shut-off valve be installed in the gas line prior to the steamer. Make sure the pipes are clean and free of obstructions, dirt, and piping compound.

NOTICE: If applicable, the vent line from the gas appliance pressure regulator shall be installed to the outdoors in accordance with local codes or, in the absence of local codes, with the *National Fuel Gas Code, ANSI Z223.1/NFPA 54*, or the *Natural Gas and Propane Installation Code CSA B149.1*, as applicable.



WARNING: Prior to start-up, check all joints in the gas supply line for leaks. Use soap and water solution. Do not use an open flame.

ELECTRICAL CONNECTIONS



WARNING: Electrical and grounding connections must comply with the applicable portions of the National Electrical Code and/or other local codes.

120 VAC-60 Hz - Single Phase

Make electrical connection to terminal block in rear of unit. A separate 15 amp supply is needed for each unit.

Refer to the electrical diagram located inside cabinet on door.

INSTALLATION AND OPERATION MANUAL,
GAS CABINET BASE CONVECTION STEAMER, GCX-16, GCX-24

4.0 OPERATION INSTRUCTIONS

	WARNING: Do not force the gas control knob. Use only your hand to turn the gas control knob. Never use any tool. If the gas control knob will not operate by hand the gas control should be replaced by a qualified service technician.
---	--

	WARNING: Do not disassemble the gas control; it contains no replaceable components. Attempted disassembly or repair may damage the gas control.
---	--

	WARNING: In the event of main burner ignition failure, a 5 minute purge period must be observed prior to re-establishing ignition source.
---	--

For CSD-1 equipped boilers, see section 4.0 for Operation Instructions for CSD-1 Equipped Boiler.

BOILER CONTROLS (Inside Cabinet)

- Main Power Switch
 - ON fills the boiler tank and turns the boiler controls on. You should allow 20 minutes to fill the tank and generate steam.
 - OFF shuts off the boiler controls and opens the automatic blowdown valve, emptying the boiler tank and releasing water and steam to the drain. This should be done at least once daily to remove sediment, lime, or scale.
- Pilot Light
 - Indicates main power is ON.
- Boiler Pressure Gauge
 - Should read 9 -11 psi during operation; 0 psi during shutdown.
- Water Level Sight Glass
 - Observe level of water in the boiler and water quality. Murkiness in the water indicates inadequate water quality; the owner must supply proper water to the boiler (See page 4, Water Quality Statement).
- Water Level Control
 - While ON, briefly open the water level control daily to remove any sediment that might accumulate.
- Safety Valve
 - This valve will release (pop off) if the boiler has too much pressure. Once a week, this valve should be tripped during operation to make sure it functions properly.

INSTALLATION AND OPERATION MANUAL,
GAS CABINET BASE CONVECTION STEAMER, GCX-16, GCX-24

BOILER CONTROLS (Inside Cabinet) (Continued)



CAUTION: If you smell gas during the lighting procedure, immediately shut off the gas supply until the leak has been corrected.

1. START-UP - BOILER OPERATION WITH STANDING PILOT IGNITION

Open manual gas shut off supply valve and if the appliance has a manual blowdown valve, close it. Open cabinet door and turn ON power switch located on left side. Green pilot light will come on, water will begin to enter boiler and required water level will be reached in about three minutes. Observe water gauge glass to verify.

The dial on the combination gas control valve has three positions (ON-PILOT-OFF) for manual gas control of main burners and pilot. Turn DIAL to PILOT. Depress dial and light burner located on centre main burner of boiler. Maintain dial in depressed position for about 30 seconds and release. Observe that the pilot burner flame stays on. If at any time the flame should become extinguished, a 5 minute period of complete shut off of gas supply is required before relighting.

Turn dial to ON and burners should ignite. Steam generation will now commence and be completed in approximately 15 minutes. Steam generation should reach approximately 11 psi as indicated on the pressure gauge on the boiler.

2. START UP - BOILER OPERATION WITH ELECTRONIC IGNITION

Open manual gas supply valve.

Open cabinet door and turn main power switch ON. Green pilot light will come on, water will begin to enter boiler and required water level will be reached in about three minutes. Observe water gauge sight glass to verify.

INSTALLATION AND OPERATION MANUAL,
GAS CABINET BASE CONVECTION STEAMER, GCX-16, GCX-24

5.0 OPERATION INSTRUCTIONS FOR BOILERS WITH CSD-1 CONTROLS



WARNING: In the event of main burner ignition failure, a 5 minute purge period must be observed prior to re-establishing ignition source.

INITIAL START-UP PROCEDURE

1. Open the manual gas shut-off supply valve.
2. Close the manual blowdown valve, if so equipped.
3. Light the pilot burner.

The dial on the gas combination valve has three positions (ON - OFF - PILOT) for manual gas control of main burners and pilot burner. Turn the dial on the gas combination valve to "PILOT", depress the dial and light the pilot burner on the centre burner. Maintain the dial in depressed position for about 30 seconds and release. Observe the pilot flame stays ON. Turn dial to "ON".

If at any time the flame should become extinguished, a five (5) minute purging is required before relighting is attempted.

4. Open cabinet door and turn "ON" the power switch.

The green pilot light will come "ON". Water should begin to enter the boiler. When enough water has entered the boiler the (amber) "STANDBY" pilot light will come on.

5. Press the "RESET" switch to begin boiler operation.

The "STANDBY" pilot light will go off and the boiler will begin operation.

INSTALLATION AND OPERATION MANUAL,
GAS CABINET BASE CONVECTION STEAMER, GCX-16, GCX-24

5.0 OPERATION INSTRUCTION FOR BOILERS WITH CSD-1 CONTROLS (Continued)

Daily Startup Procedure

1. Close the manual blowdown valve, if so equipped.
2. Examine that the pilot burner flame is burning. If the pilot burner is out, a five (5) minute period of complete gas supply shut off is required before relighting.
3. Open cabinet door and turn "ON" the power switch.

The green pilot light will come "ON". Water will begin to enter the boiler. When enough water has entered the boiler the (amber) "STANDBY" pilot light will come on.

4. Press the "RESET" switch to begin the boiler operation. The "STANDBY" pilot light will go off and the boiler will begin operation.

Daily Shutdown Procedure

1. Turn "OFF" the power switch. Observe that the burners go off.
2. Open the manual blowdown valve, if so equipped. If the appliance is equipped with an automatic blowdown solenoid valve, the boiler's contents, water and steam will be blown out and exhausted through the appliance drain. The cold water solenoid valve will be activated.

Complete Shutdown Procedure

If the appliance is not intended to be operational for a lengthy period, then shut it down completely.

1. Open the manual blowdown valve, if so equipped.
2. Shut off all supplies of power, gas and water to the appliance.

INSTALLATION AND OPERATION MANUAL,
GAS CABINET BASE CONVECTION STEAMER, GCX-16, GCX-24

5.0 OPERATION INSTRUCTION FOR BOILERS WITH CSD-1 CONTROLS (Continued)

Normal Boiler Operating Cycle

Water Fill Cycle

On the initial filling of the boiler, the reset switch must be activated to initialize the safety lockout circuit. Once the water in the boiler has reached the proper level, the level control will open the circuit to the fill solenoid valve, stopping the flow of water to the boiler. As the water is consumed in the production of steam, the level control will close the circuit to the fill solenoid and water will be supplied to the boiler.

Firing Cycle

The gas valve is operated by pressure sensing devices. On the initial operation of the boiler, steam generation should reach 11 psi in approximately 15 minutes. At this point the "Operating Pressure" switch will open, closing the gas valve. When pressure drops to 9 psi, the pressure switch closes, the gas valve will open and ignition should occur.

Should the pressure rise more than 14.5 psi the "Override Pressure Switch" will close the circuit to the override solenoid valve, releasing excess steam.

Condensing Drain

A thermostat is located in the drain assembly and is activated by the temperature of steam. The thermostat opens the cooling solenoid valve, in turn supplying water to the drain to condense steam.

Automatic Blowdown Valve

If the unit has an automatic blowdown valve, it is activated by the main power switch. The boiler will be drained should the main power switch be turned "OFF".

INSTALLATION AND OPERATION MANUAL,
GAS CABINET BASE CONVECTION STEAMER, GCX-16, GCX-24

5.0 OPERATION INSTRUCTION FOR BOILERS WITH CSD-1 CONTROLS (Continued)

SAFETY LOCKOUT CONDITIONS

High Temperature Condition

A high temperature safety device is installed on the boiler. Should the temperature exceed the limit of this device, the boiler will be shut down and put in a state of lockout. The “Temperature” pilot light (red), and the “Standby” pilot (amber), will come on.

High Pressure Condition

A high pressure safety switch is installed on the boiler. Should the pressure exceed the limit of this device, the boiler will be shut down and put into a state of lockout. The “Pressure” pilot light (red), and the standby pilot light (amber), will come on. Should this device fail to operate, the safety relief valve will open.

Low Water Condition

A second low water safety cut off is supplied with the boiler. Should the water level fall below normal operating levels, this device will shut down and put the boiler in a state of lockout. The “Low Water” pilot light (red), and the “Standby” pilot light (amber) will come on.

INSTALLATION AND OPERATION MANUAL,
GAS CABINET BASE CONVECTION STEAMER, GCX-16, GCX-24

6.0 OPERATION INSTRUCTIONS - COOKER SECTION



CAUTION: Live steam and accumulated hot water in the compartment may be released when the door is opened.

Start-up procedures for your cooker must be completed once daily prior to operation. (See instruction plate or previous section in this manual for boiler start up procedures).

If appliance is equipped with optional - "Load Compensating Timer" a pre-heat thermostat is installed in each compartment. This allows the compartment to pre-heat to 185°F before the cooking time starts. Set timer for one minute. Ready light will go out and cook light will come on; steam will enter compartment. Once compartment has reached the pre-heat temperature (185°F) the timer will start. After the time selected has elapsed, buzzer will sound indicating the end of the cooking cycle. Steam generation will cease, Cook light will go out and Ready light will come on. To silence buzzer turn timer to its off position.

With ready pilot light on, preheat steamer compartment for one minute when the steamer is to be first used for the day or whenever the compartment is cold.

Close compartment doors and set timer to "1 minute".

1. When buzzer sounds, set timer to the "OFF" position.
2. Steamer is now ready for cooking.
3. With cooking compartment preheated and ready pilot light on, place pans of food to be cooked into compartment and shut door.
4. Set timer to cooking time desired. Cooking cycle may be interrupted at any time by opening door and resumed again by closing door.
5. When buzzer sounds, it indicates the end of the cooking cycle and that no more steam is entering the compartment. Cooking pilot light will go off and ready pilot light will come on. Buzzer must be shut off by turning the timer to its off position.

6.0 OPERATION INSTRUCTIONS - COOKER SECTION (Continued)

	CAUTION: An obstructed drain can cause personal injury or property damage.
---	---

Frequently check that the compartment drain and plumbing are free of all obstructions. Never place food containers, food or food portion bags in the cooking compartment in such a way that the compartment drain becomes obstructed.

	IMPORTANT: Each compartment is equipped with a removable drain screen. Frequently check the drain screen for accumulation of food particles. Should food particles accumulate against, or clog the drain screen, remove it, clean it thoroughly and then replace it in its original position.
---	--

SHUTDOWN

- a) To shut down cooking compartment, set timers to their OFF position and leave doors slightly open.
- b) At the end of the day, the steam supply must be shut off. Details are on boiler instruction plate or previous section of this manual.

	WARNING: Never spray water into electric controls.
---	---

	NOTICE: Contact the factory, the factory representative or a local service company to perform maintenance and repairs should the appliance malfunction. Refer to warranty terms.
---	---

INSTALLATION AND OPERATION MANUAL,
GAS CABINET BASE CONVECTION STEAMER, GCX-16, GCX-24

7.0 PERIODIC MAINTENANCE



WARNING: Disconnect the unit from the power supply before cleaning or servicing appliance.

Be sure to flush your boiler water level control daily. Failure to follow this procedure can cause the control to malfunction resulting in serious boiler damage.

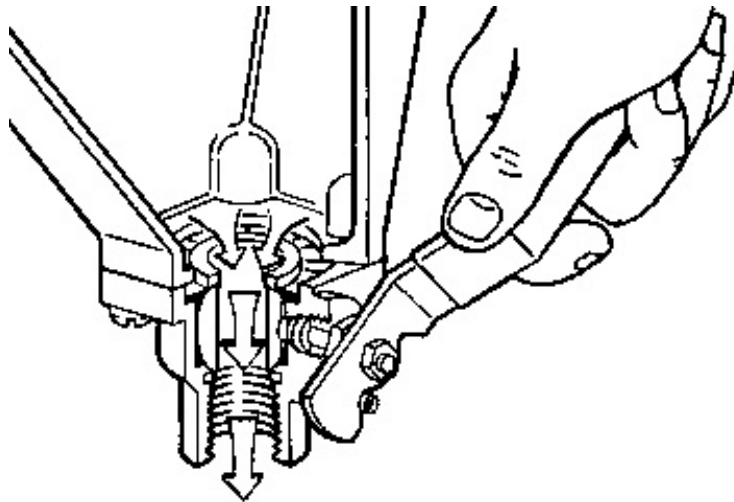

The Boiler Water Level Control installed on your boiler requires periodic maintenance. As boiler water circulates into the float chamber, sand, scale and other sediment may be deposited in the float chamber. While the chamber has been designed with a large accumulation bowl, it is necessary to flush the sediment from the chamber by blowing down the control so that the accumulation of sediment does not interfere with the movement of the float in the control. Control must be flushed at least once a day.



CAUTION: Protect yourself. When flushing control, hot water and steam will flow out of the drain.

When flushing control, note water level in gauge glass, allow the boiler to fill if necessary, and also to come up to temperature.

Before flushing control, note that water level in gauge glass is within operating range and the boiler pressure is at least 6 psi. While the boiler is being operated, open blowdown valve at bottom of control by rotating the handle counterclockwise about 1/4 turn to fully open the valve. Opening the blowdown valve also checks the cut-off operation. Float should drop shutting steam off, hot water and steam will flow out the drain flushing away sediment.

INSTALLATION AND OPERATION MANUAL,
GAS CABINET BASE CONVECTION STEAMER, GCX-16, GCX-24

7.0 PERIODIC MAINTENANCE (Continued)



CAUTION: If burner does not shut off during blowdown, immediately discontinue use of appliance and call for service.

Continue draining water for about fifteen (15) seconds, from control until water is clean. Manually close valve. Recheck gauge glass. If water level has dropped significantly, wait for the boiler to restore water level and pressure and repeat if necessary.

1. Observe that the water in gauge glass is clean and clear. Extreme murkiness in water indicates inadequate water quality.
2. Safety valve should be tripped during operation once a week to assure that it functions properly.
3. Keep all exposed cleanable areas of unit clean at all times



CAUTION: Take extra caution when blowing down water level control or tripping safety valve as extreme hot water and live steam are present.

REMOVAL OF SCALE DEPOSITS

This equipment should be installed with the Middleby TruH2O water treatment system which, when properly maintained can provide a scale-free environment for your steamer. However, because water quality can vary it is recommended that the steamer be checked every 90 to 120 days for scale build up. Regular maintenance should be carried out at this time.

DESCALING BOILER

If the boiler has been descaled, a new Anode should be installed in the boiler.

1. With boiler empty, close manual blowdown valve. If appliance is equipped with automatic blowdown, turn water supply OFF to appliance. Turn power switch ON. This will energize and close blowdown valve.
2. Remove 3/4" pipe plug from fitting on left front of boiler.
3. Insert appropriate hose or tube through fitting and pour in (1/2) half gallon (U.S.) of CLR Descaling Solution or use the Optional Deliming Assembly DPA-1 available from your dealer.

INSTALLATION AND OPERATION MANUAL,
GAS CABINET BASE CONVECTION STEAMER, GCX-16, GCX-24

7.0 PERIODIC MAINTENANCE (Continued)

DESCALING BOILER (Continued)

For appliances equipped with CSD-1, descaling solution must be introduced through hand hole.

4. Replace 3/4" pipe plug securely.
5. Open water supply to appliance allowing water to fill boiler to required level.
6. Let appliance cycle, allow two hours for descaling and cleaning. DO NOT TURN STEAM ON TO THE COMPARTMENTS.
7. Open both the blowdown and low water level control valves for complete drainage and then close both valves.

Appliance equipped with automatic blowdown - turn OFF power switch and open low water control valve. This will allow complete drainage. Once drained close water level control valve.

8. Turn appliance switch ON. When boiler is completely filled, turn power switch OFF. This will rinse and drain boiler. Appliance with manual blowdown valve must be opened to drain.
9. Complete Step 8 twice to assure boiler is completely rinsed.
10. Appliance is now ready for use.

INSTALLATION AND OPERATION MANUAL,
GAS CABINET BASE CONVECTION STEAMER, GCX-16, GCX-24

8.0 CLEANING INSTRUCTIONS

	CAUTION: Never spray water into electric controls.
---	---

	CAUTION: Do not use cleaning agents that are corrosive.
---	--

	CAUTION: Live steam and accumulated hot water in the compartment may be released when the door is opened.
---	--

1. Keep exposed cleanable areas of unit clean at all times.
2. Thoroughly wash steamer cavities, door liners, and pan racks at the end of each day, or as required, with a mild detergent and water to prevent bacterial growth and odours.
3. Remove drain screens from inside compartment drains. Using a plastic bottle brush and mild detergent, clean inside the drain opening ensuring there is no food residue or blockage. Clean the drain screen and replace in its original position.
4. Wash gasket sealing surface daily with mild detergent to remove harmful food acids.
5. Clean around burner air mixer and orifice if lint has accumulated.
6. Visually assure carry over ports are unobstructed.
7. Rinse entire unit and dry. **DO NOT GET WATER** in electrical box or any electrical component.

INSTALLATION AND OPERATION MANUAL,
GAS CABINET BASE CONVECTION STEAMER, GCX-16, GCX-24

9.0 ADJUSTMENTS

TO CALIBRATE PRESSURE SWITCHES

NOTE: Pressure switches are factory set. Calibration is only required if pressure switches are replaced or if adjustment is required.

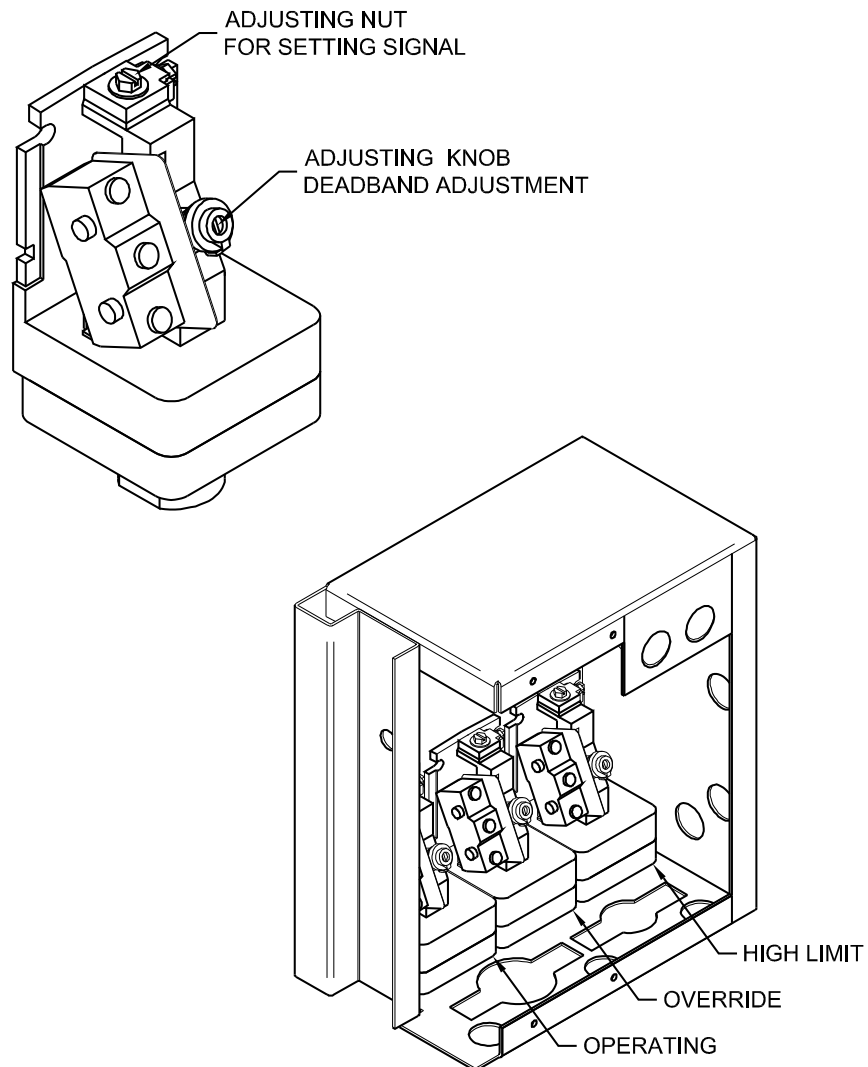

INSTALLATION AND OPERATION MANUAL,
GAS CABINET BASE CONVECTION STEAMER, GCX-16, GCX-24

9.0 **ADJUSTMENTS** (Continued)

TO CALIBRATE PRESSURE SWITCHES (Continues)



CAUTION: Adjusting knob and nut will turn easily until they hit a stop. Do not over torque. Over torquing may cause damage.

1. Turn the adjusting knob clockwise to the deadband to maximum.
2. Turn the adjusting nut clockwise to maximum.
3. Adjust in the following sequence:
 - High limit pressure switch.
 - Override pressure switch. (if equipped).
 - Operating pressure switch.
 - Use relief valve to release pressure from boiler for setting adjustments.

High Limit Pressure Switches

Allow pressure to build until unit shuts off. This should occur at 15 PSI. Set the adjusting nut to switch off at 14.5 PSI on the gauge.

Override Pressure Switches

Set the adjusting nut to switch off at 13 PSI on the gauge.

Operating Pressure Switches

Set the high signal to switch off at 11 PSI on the gauge.

4. Release pressure in boiler below 9 PSI. The boiler should fire and once the pressure has reached 11 PSI, the boiler should shut off. Repeat this process several times to make sure boiler operates between 9 and 11 PSI.

Once completed, pressure switches have been calibrated.

INSTALLATION AND OPERATION MANUAL,
GAS CABINET BASE CONVECTION STEAMER, GCX-16, GCX-24

10.0 TROUBLESHOOTING

	NOTICE: Contact the factory, the factory representative or local service company to perform maintenance and repairs. Refer to warranty terms.
---	--

	NOTICE: At least twice a year have an authorized service person clean and adjust the unit for maximum performance.
---	---

DOOR LEAKS

1. Check for damage to door gasket.
2. Compartment drain opening or associated piping may be blocked.

WATER ACCUMULATES IN THE COMPARTMENT

1. Compartment drain screen clogged. Remove and clean thoroughly and replace.

SAFETY VALVE BLOWS

1. Defective safety valve.
2. Pressure too high. Pressure switch requires adjustment (lower) or may be defective.

WATER NOT BEING SUPPLIED TO BOILER

1. Water supply is "OFF".
2. Defective water fill solenoid valve.
3. Water level control clogged or defective, unable to operate fill valve.
4. Check drain valve is closed. Also check that water level control valve is closed.
5. Supply water pressure too low.

INSTALLATION AND OPERATION MANUAL,
GAS CABINET BASE CONVECTION STEAMER, GCX-16, GCX-24

10.0 TROUBLESHOOTING (Continued)

AUTOMATIC BLOWDOWN VALVE DOES NOT DRAIN

1. Defective blowdown valve.
2. Heat exchanger build up of scalant clogging drain lines and valve.

BOILER ACHIEVES PRESSURE SLOWER THAN NORMAL

1. Heavy build up of lime or scalant hampering heat transfer. Call for service to inspect interior of boiler. Should a considerable amount of scalant be found, have steam lines, water level control and valve also inspected.

BURNERS PRODUCE CARBON DEPOSITS

1. Wrong size orifices.
2. Burner air not adjusted properly.
3. Wrong gas supply.
4. Incorrect pressure at supply.

BURNERS DO NOT COME ON

1. Gas supply to unit is "OFF".
2. Manual shut off valve is "OFF".
3. Pilot is out.
4. Power supply is "OFF".
5. Water level has not been reached. Check water supply and water level control.
6. Pilot may require flame adjustment on option electronic ignition units.
7. If water at proper level, check relay which energizes pressure switch and gas valve.
8. Pressure switch may need to be replaced if relay is operating.
9. Check gas control. If energized but not operating, have replaced.

INSTALLATION AND OPERATION MANUAL,
GAS CABINET BASE CONVECTION STEAMER, GCX-16, GCX-24

10.0 TROUBLESHOOTING (Continued)

PILOT LIGHT DOES NOT IGNITE (ELECTRONIC IGNITION)

1. Gas control knob is in "OFF" position.
2. Loose or dirty wire connection to ignition module, clean/or tighten.
3. Ignition cable shorting out. Check that it is not in contact with metal or damaged.
4. Defective ignition module.
5. Unit is 100% lock out. Turn off and try in five minutes.
6. Dirty flame sensor. Clean with emery cloth.
7. Pilot burner/ignitor sensor, cracked ceramic insulator. Have replaced.
8. Check for too much draft in room.